

**TECHNICAL MANUAL**

**UNIT AND INTERMEDIATE DIRECT SUPPORT (DS)  
MAINTENANCE MANUAL (INCLUDING REPAIR PARTS  
AND SPECIAL TOOLS LIST)  
FOR**

**PARACHUTE, CARGO TYPE: 22-FOOT  
DIAMETER, CARGO EXTRACTION  
PARACHUTE**

**NSN 1670-01-063-3716 AND  
NSN 1670-00-687-5458**

Approved for public release. Distribution is unlimited.

This copy is a reprint which includes current pages from Changes 1 and 2.

The following manuals, TM 10-1670-275-23&P, TM 10-1670-276-23&P, TM 10-1670-277-23&P, TM 10-1670-278-23&P, TM 10-1670-279-23&P, TM 10-1670-280-23&P, TM 10-1670-281-23&P, TM 10-1670-282-23&P, in their entirety, supersede TM 10-1670-215-23, dated 7 December 1973, including all changes.

---

**HEADQUARTERS  
DEPARTMENTS OF THE ARMY, AIR FORCE, AND NAVY**

**30 AUGUST 1989**



**WARNING**

DEATH could result if inspections are not performed as specified in this manual. Perform all inspections as specified.

**WARNING**

DEATH from burns or parachute failure could result if cleaning solvents other than tetrachloroethylene are used in cleaning this equipment. Other solvents shall not be used because of their flammable properties and nylon-damaging substances.

**WARNING**

Prolonged inhalation of tetrachloroethylene vapors can cause respiratory injury. Provide adequate ventilation when using it. Also avoid skin contact. Repeated exposure can cause injury.

**WARNING**

Exercise extreme care when using petroleum products to destroy equipment by fire, as severe burns or DEATH could result.

**WARNING**

FIRST AID

For First Aid treatment, refer to FM 21-11



CHANGE  
NO. 4

HEADQUARTERS, DEPARTMENT OF THE ARMY  
WASHINGTON, DC, 31 AUGUST 2005

TECHNICAL MANUAL  
UNIT AND INTERMEDIATE DIRECT SUPPORT (DS)  
MAINTENANCE MANUAL (INCLUDING REPAIR PARTS  
AND SPECIAL TOOLS LIST)  
FOR  
PARACHUTE, CARGO TYPE: 22-FOOT  
DIAMETER, CARGO EXTRACTION  
PARACHUTE

**DISTRIBUTION STATEMENT A:** Approved for public release; distribution is unlimited.

TM 10-1670-279-23&P, 30 August 1989, is updated as follows:

1. File this sheet in front of the manual for reference.
2. This change implements Army Maintenance Transformation and changes the Maintenance Allocation Chart (MAC) to support Field and Sustainment Maintenance.
3. New or updated change information is indicated by a vertical bar in the outer margin of the page.
4. Remove old pages and insert new pages as indicated below:

**Remove Pages**

A/(B Blank)  
B-1 - B-7/(B-8 Blank)  
Electronic 2028 Instructions/Blank  
Sample 2028/Envelope  
2028 Front/Envelope

**Insert Pages**

A/(B Blank)  
B-1 - B-7/(B-8 Blank)  
Electronic 2028 Instructions/Blank  
Sample 2028/Back  
2028 Front/Back  
2028 Front/Back

**ARMY TM 10-1670-279-23&P**  
**AIR FORCE T.O. 13C5-27-2**  
**NAVY NAVAIR 13-1-28**

**C4**

By Order of the Secretaries of the Army, Air Force, and Navy (including the Marine Corps):

**PETER J. SCHOOMAKER**  
*General, United States Army*  
*Chief of Staff*

Official:

  
**SANDRA R. RILEY**  
*Administrative Assistant to the*  
*Secretary of the Army*  
0521618

**MICHAEL E. RYAN**  
*General, USAF*  
*Chief of Staff*

Official:

**GEORGE T. BABBETT**  
*General, USAF*  
*Commander, Air Force Materiel Command*

**D.G. MORRAL**  
*Rear Admiral, USN*  
*Program Executive Officer*  
*For Expeditionary Warfare*  
*Naval Sea Systems Command*

Distribution:

To be distributed in accordance with initial distribution number (IDN) 252516 requirements for TM 10-1670-279-23&P.

CHANGE  
NO. 3

HEADQUARTERS DEPARTMENTS OF  
THE ARMY THE AIR FORCE AND THE NAVY  
WASHINGTON, D.C., 20 MARCH 2001

**Unit and Intermediate Direct Support (DS) Maintenance Manual  
(Including Repair Parts and Special Tools List)  
for  
PARACHUTE, CARGO TYPE: 22-FOOT DIAMETER,  
CARGO EXTRACTION PARACHUTE  
NSN 1670-01-063-3716  
AND  
NSN 1670-00-687-5458**

DISTRIBUTION STATEMENT A: Approved for public release; distribution is unlimited

TM, 10-1670-279-23&P/T.O. 13C5-27-2/NAVAIR 13-1-28, 30 August 1989, is changed as follows:

1. Remove and insert pages as indicated below. New or changed text material is indicated by a vertical bar in the margin. An illustration change is indicated by a miniature pointing hand.

Remove pages

-----

i and ii

2-33 and 2-34

Insert pages

A/(B Blank)

i and ii

2-33 and 2-34

2. Retain this sheet in front of manual for reference purposes.

C-3

By Order of the Secretaries of the Army, Air Force, and Navy:

ERIC K. SHINSEKI  
*General, United States Army*  
*Chief of Staff*

Official:

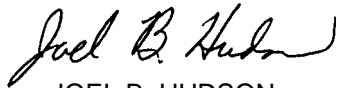

JOEL B. HUDSON  
*Administrative Assistant to the*  
*Secretary of the Army*

0106803

RONALD R. FOGELMAN  
*General, USAF*  
*Chief of Staff*

Official:

HENRY VICCELLIO, JR.  
*General, USAF*  
*Commander, Air Force Materiel Command*

J. E. BUFFINGTON  
*Rear Admiral, CEC, US Navy*  
*Commander*  
*Navy Facilities Engineering*  
*Command*

DISTRIBUTION:

To be distributed in accordance with initial distribution (IDN 252516), requirements for  
TM 10-1670-279-23&P.



CHANGE  
NO. 2

HEADQUARTERS  
DEPARTMENTS OF THE ARMY, AIR FORCE AND NAVY  
WASHINGTON, D.C., 31 March 1993

Unit and Intermediate Direct Support (DS) Maintenance Manual  
(Including Repair Parts and Special Tools List)  
for

PARACHUTE, CARGO TYPE: 22-FOOT DIAMETER,  
CARGO EXTRACTION PARACHUTE  
NSN 1670-01-063-3716  
AND  
NSN 1670-00-687-5458

DISTRIBUTION STATEMENT A: Approved for public release; distribution is unlimited.

TM 10-1670-279-23&P/T.O. 13C5-27-2/NAVAIR 13-1-28, 30 August 1989 is changed as follows:

1. Remove and insert pages as indicated below. New or changed text material is indicated by a vertical bar in the margin. An illustration change is indicated by a miniature pointing hand.

Remove pages

2-127 and 2-128  
C-17 through C-20  
D-3 and D-4

Insert pages

2-127 and 2-128  
C-17 through C-20  
D-3 and D-4

2. Retain this sheet in front of manual for reference purposes.

ARMY TM 10-1670-279-23&P  
AIR FORCE T.O. 13C5-27-2  
NAVY NAVAIR 13-1-28  
C2

**By Order of the Secretaries of the Army, Air Force, and Navy  
(Including the Marine Corps):**

Official:

  
MILTON H. HAMILTON  
*Administrative Assistant to the  
Secretary of the Army*  
03977

GORDON R. SULLIVAN  
*General, United States Army  
Chief of Staff*

**MERRILL A. McPEAK**  
*General, USAF  
Chief of Staff*

Official:

**RONALD W. YATES**  
*General, USAF  
Commander, Air Force Materiel Command*

**DAVID E. BOTTORFF**  
*Rear Admiral, CEC, US Navy  
Commander  
Navy Facilities Engineering  
Command*

**RONALD D. ELLIOT**  
*Executive Director  
Marine Corps Systems Command*

**DISTRIBUTION:**

To be distributed in accordance with DA Form 12-25-E, block no. 2516,  
requirements for TM 10-1670-279-23&P.

CHANGE  
NO. 1

HEADQUARTERS,  
DEPARTMENTS OF THE ARMY, NAVY AND AIR FORCE  
WASHINGTON, D.C., 11 June 1991

Unit and Intermediate Direct Support (DS) Maintenance Manual  
(Including Repair Parts and Special Tools List)  
for

**PARACHUTE, CARGO TYPE: 22-FOOT DIAMETER,  
CARGO EXTRACTION PARACHUTE  
NSN 1670-01-063-3716  
AND  
NSN 1670-00-687-5458**

Approved for public release; distribution is unlimited

TM 10-1 670-279-23&P/T.O. 13C5-27-2/NAVAIR 13-1-28, 30 August 1989 is changed as follows:

1. Remove and insert pages as indicated below. New or changed text material is indicated by a vertical bar in the margin. An illustration change is indicated by a miniature pointing hand.

Remove pages

iii and iv  
2-7 through 2-10  
2-41 and 2-42  
- - - - -

Insert pages

iii and iv  
2-7 through 2-10  
2-41 and 2-42  
2-42.1/(2-42.2 blank)

2. Retain this sheet in front of manual for reference purposes.

By Order of the Secretaries of the Army, Air Force, and Navy:

**CARL E. VUONO**  
*General, United States Army*  
*Chief of Staff*

Official:

**PATRICIA P. HICKERSON**  
*Brigadier General, United States Army*  
*The Adjutant General*

**MERRILL A. McPEAK**  
*General USAF*  
*Chief of Staff*

Official:

**CHARLES C. McDONALD**  
*General, USAF*  
*Commander, Air Force Logistics Command*

**DAVID E. BUTTORFF**  
*Rear Admiral, CEC, US Navy*  
*Commander*  
*Navy Facilities Engineering Command*

DISTRIBUTION:

To be distributed in accordance with DA Form 12-25E, (qty rqr block no. 5061).

INSERT LATEST CHANGED PAGES. DESTROY SUPERSEDED PAGES.

**LIST OF EFFECTIVE PAGES**

NOTE: The portion of text affected by the changes is indicated by a vertical line in the outer margins of the page. Changes to illustrations are indicated by shaded or screened areas, or by miniature pointing hands. Zero in the "Change No." column indicates an original page.

Dates of issue for original and changed pages are:

Original ... 0 ...	30 August 1989	Change ... 3 ...	20 March 2001
Change ... 1 ...	11 June 1991	Change ... 4 ...	31 August 2005
Change ... 2 ...	31 March 1993		

**TOTAL NUMBER OF PAGES IN THIS PUBLICATION IS 216, CONSISTING OF THE FOLLOWING:**

<b>Page No.</b>	<b>Change No.</b>
Front Cover	0
Title	0
a/(b Blank)	0
i	3
li	0
iii	1
iv	0
1-1 - 1-9/(1-10 blank)	0
2-1 - 2-7	0
2-8 - 2-9	1
2-10 - 2-33	0
2-34	3
2-35 - 2-40	0
2-41 - 2-421/(2-42.2)	1
2-43 - 2-126	0
2- 127	2
2-128 - 2-133/(2-134 blank)	0
A-1 - A-2	0
B-1 - B-7/(B-8 blank)	4
C-1 - C-17	0
C-18 - C-20	2
D-1 - D-3	0
D-4	2
E-1/(E-2 blank)	0
INDEX 1 - INDEX 4	0
Back Cover	0



TECHNICAL MANUAL 10-1670-279-23&P  
 TECHNICAL ORDER 13C5-27-2  
 NAVAIR 13-1-28

HEADQUARTERS  
 DEPARTMENTS OF THE ARMY, AIR FORCE  
 AND THE NAVY  
 WASHINGTON, D.C., 30 August 1989

**Unit and Intermediate Direct Support (DS) Maintenance Manual  
 (Including Repair Parts and Special Tools List)  
 for  
 PARACHUTE, CARGO TYPE: 22-FOOT DIAMETER  
 CARGO EXTRACTION PARACHUTE ASSEMBLY  
 NSN 1670-01-063-3716 and  
 NSN 1670-00-687-5458**

DISTRIBUTION STATEMENT A: Approved for public release; distribution is unlimited

**REPORTING ERRORS AND RECOMMENDING IMPROVEMENTS**

You can help improve this manual. If you find any mistakes, or if you know of a way to improve these procedures, please let us know. Mail DA Form 2028 (Recommended Changes to Publications and Blank Forms), or DA Form 2028-2, located in the back of this manual, direct to: Commander, U.S. Army Soldier Biological and Chemical Command, ATTN: AMSSB-RIM-E (N), 15 Kansas Street, Natick, MA 01760. You may also send in your recommended changes via electronic mail directly to <AMSSB-RIM-E@natick.army.mil>. A reply will be furnished directly to you. Instructions for sending an electronic 2028 may be found at the back of this manual immediately preceding the hard copy 2028.

For Air Force, submit AFTO Form 22 (Technical Order System Publication Improvement Report and Reply) in accordance with paragraph 6-5, Section VI, T.O. 00-5-1. Forward to Commander, San Antonio Air Logistics Center, ATTN: SA-ALC/TIRTR, Kelly Air Force Base, TX 78241-5000.

In either case, a reply will be furnished direct to you

**TABLE OF CONTENTS**

		<b>PAGE</b>
CHAPTER 1	INTRODUCTION .....	1-1
	OVERVIEW .....	1-1
Section I	General .....	1-1
Section II	Equipment Description and Data .....	1-4
CHAPTER 2	UNIT AND INTERMEDIATE DIRECT SUPPORT FUNCTIONS .....	2-1
	OVERVIEW .....	2-1
Section I	Repair Parts, Special Tools, Test Measurement and Diagnostic Equipment (TMDE) and Support Equipment .....	2-1
Section II	Service Upon Receipt .....	2-2
Section III	Assembly .....	2-8
Section IV	Preventive Maintenance Checks and Services .....	2-10
Section V	Unit and Intermediate Direct Support (DS) Maintenance Procedures ...	2-12
Section VI	Repair .....	2-50
Section VII	Preparation for Storage and Shipment .....	2-131

TABLE OF CONTENTS (cont)

		Page	Illust/ Figure
APPENDIX A	REFERENCES.....	A-1	
APPENDIX B	MAINTENANCE ALLOCATION CHART.....	B-1	
APPENDIX C	REPAIR PARTS AND SPECIAL TOOLS LIST .....	C-1	
Section I	Introduction .....	C-1	
Section II	Repair Parts List.....	C-10	
Group 00	Parachute, Cargo Type, 22-Foot Diameter Cargo Extraction.....	C-10	C-1
Group 01	Canopy, Cargo Extraction Parachute, 22-Foot Diameter.....	C-12	C-2
Group 02	Deployment Bag, Parachute .....	C-14	C-3
Group 03	Adapter Web, Extraction Parachute .....	C-16	C-4
Group 04	Extraction Line (no listing required) .....		
Group 05	Bulk Materials .....	C-18	
Section III	Special Tools List (not applicable)		
Section IV	Cross Reference Indexes .....	C-19	
APPENDIX D	EXPENDABLE/DURABLE SUPPLIES AND MATERIALS LIST .....	D-1	
APPENDIX E	ILLUSTRATED LIST OF MANUFACTURED ITEMS .....	E-1	
INDEX	.....	Index 1	



LIST OF ILLUSTRATIONS

Figure Number	Title	Page
1-1	22-Foot Diameter Cargo Extraction Parachute, Deployed .....	1-2
1-2	Canopy Assembly and Adapter Web .....	1-5
1-3	Extraction Line .....	1-6
1-4	Deployment Bag.....	1-7
2-1	Installing Attachment Tie on Parachute Log Record .....	2-3
2-2	Inside Front Cover of Parachute Log Record .....	2-4
2-3	Inside Back Cover of Parachute Log Record .....	2-5
2-4	Log Record Entries for the Modification Work Order Compliance Record Page .....	2-5
2-5	Log Record Entries for Unit and Intermediate Repair and Inspection Data Page .....	2-6
2-6	Data Entries for a Log Record Note Page .....	2-7
2-7	DELETED .....	2-9
2-8	Shakeout.....	2-15
2-9	Rigger's Orientation.....	2-27
2-10	Canopy Attached to Packing Table Apex Hook .....	2-28
2-11	Removing Inversion .....	2-29
2-12	Removing Partial Inversion .....	2-30
2-13	Removing Turns from Suspension Lines .....	2-31
2-14	Removing Tangles from Suspension Lines .....	2-32
2-15	Removing Twists from Suspension Lines .....	2-33
2-16	Line 1 and 28/14 and 15 Checked at Connector Link .....	2-34
2-17	Dressing the Apex .....	2-35
2-18	Flipping Right Group of Gores .....	2-36
2-19	Folding Right Gore .....	2-37
2-20	Left Gore Group Fold Complete .....	2-38
2-21	Draping Folded Gores .....	2-39
2-22	Flat Fold Complete.....	2-39
2-23	Long Fold Complete .....	2-40
2-24	Attaching Bridle Loop to Deployment Bag .....	2-41
2-25	Stowing Canopy .....	2-43
2-26	Stowing Suspension Lines .....	2-44
2-27	Suspension Line Connector Link Assemblies in Position with Adapter Web .....	2-45
2-28	Suspension Line Stowage Flap, Rolled into Open End of Deployment Bag .....	2-46
2-29	Left and Right Deployment Bag Closing Ties .....	2-47
2-30	Bag Opening Safety Loop and Pendulum Line Secured .....	2-48
2-31	Stowing the Extraction Line .....	2-49
2-32	Darning Method Using a Darning Sewing Machine .....	2-55
2-33	Repair Method Using a Zig-Zag Sewing Machine .....	2-55
2-34	Attachment Loop Replacement Details .....	2-60
2-35	Vent Line Replacement Details .....	2-62

**LIST OF ILLUSTRATIONS (cont)**

Figure Number	Title	Page
2-36	Bridle Centering Line Details .....	2-64
2-37	Vent Reinforcement Band Splicing Details .....	2-67
2-38	Basic and Miscellaneous Patch Application .....	2-71
2-39	Gore Panel Replacement Details .....	2-73
2-40	Radial Tape Restitching Detail .....	2-75
2-41	Radial Tape Splice Details .....	2-76
2-42	Panel Edge Reinforcement Splicing Details .....	2-78
2-43	Skirt Reinforcement Splice Details (Lower Lateral Band) .....	2-80
2-44	Webbing Type Pocket Band Replacement Details .....	2-82
2-45	Cord Type Pocket Band Replacement Details .....	2-83
2-46	Replacement Suspension Line Construction Details .....	2-85
2-47	Securing Suspension Line at Suspension Line Attaching Loop .....	2-86
2-48	Suspension Line Numerical Sequence .....	2-87
2-49	Securing Suspension Line to Connector Link .....	2-88
2-50	Suspension Line Spacer .....	2-89
2-51	Connector Link Assembly .....	2-91
2-52	Deployment Bag .....	2-93
2-53	Fabricating Grommet Reinforcement .....	2-95
2-54	Grommet Installation by Hand-Held Method .....	2-96
2-55	Chuck and Die Installed in Hand-Operated Press .....	2-98
2-57	Retainer Band Keeper Replacement .....	2-100
2-58	Replacement Retainer Line Construction Details .....	2-102
2-59	Deployment Bag Retainer Line Replacement Details .....	2-103
2-60	Closing Loop Replacement Details .....	2-105
2-61	Attaching Parachute Inspection Data Pocket .....	2-107
2-62	Retainer Band Keeper Reinforcement Replacement Details .....	2-109
2-63	Tie Loop and Tie Loop Reinforcement Replacement Details .....	2-111
2-64	Safety Cord Fabrication Details .....	2-113
2-65	Safety Cord Replacement Details .....	2-114
2-66	Edge Binding Splicing Detail .....	2-116
2-67	Stowage Flap Edge Reinforcement Details .....	2-118
2-68	Patching Deployment Bag Panels and Flaps .....	2-121
2-69	Replacement Pendulum Line Construction Details .....	2-123
2-70	Pendulum Line Replacement Details .....	2-124
2-71	Long Buffer Replacement Details .....	2-128
2-72	Type IV Quick Release Link Assembly Repair .....	2-131

**LIST OF TABLES**

Number	Title	Page
2-1	Unit and Intermediate Preventive Maintenance Checks and Services (PMCS) .....	2-11
2-2	Sewing Machine Code Symbols .....	2-52
2-3	Stitching and Restitching Specifications .....	2-52

CHAPTER 1

INTRODUCTION

		Page
Section I	General.....	1-1
Section II	Equipment Description and Data.....	1-3

OVERVIEW

This chapter includes the general information common to all parachute manuals and specific information pertinent to the parachute described in this manual.

Section I. GENERAL

Paragraph		Page
1-1	Scope.....	1-1
1-2	Maintenance Forms and Records.....	1-1
1-3	Destruction of Army Materiel to Prevent Enemy Use .....	1-1
1-4	Preparation for Storage or Shipment .....	1-3
1-5	Reporting of Equipment Improvement Recommendations (EIR).....	1-4

**1-1. Scope.** The scope of this manual is described in the following subparagraphs.

*a. Type of Manual.* This manual provides unit and intermediate direct support (DS) maintenance instructions for parachute, NSN 1670-01-063-3716 and NSN 1670-00-687-5458. This is a 22-Foot Diameter Cargo Extraction Parachute (figure 1-1). This manual also provides a Repair Parts and Special Tools List located at Appendix C.

*b. Equipment Name.* 22-Foot Diameter, Cargo Extraction Parachute.

*c. Purpose of Equipment.* The parachute provides force to extract an air delivery load from aircraft.

**1-2. Maintenance Forms and Records.** Department of the Army forms and procedures used for equipment maintenance will be those prescribed by DA PAM 738-750, The Army Maintenance Management System and DA PAM 738-751, The Army Maintenance Management System - Aviation.

**1-3. Destruction of Army Materiel to Prevent Enemy Use.** Destruction methods are described in the following subparagraphs.

1-1. Scope (cont).

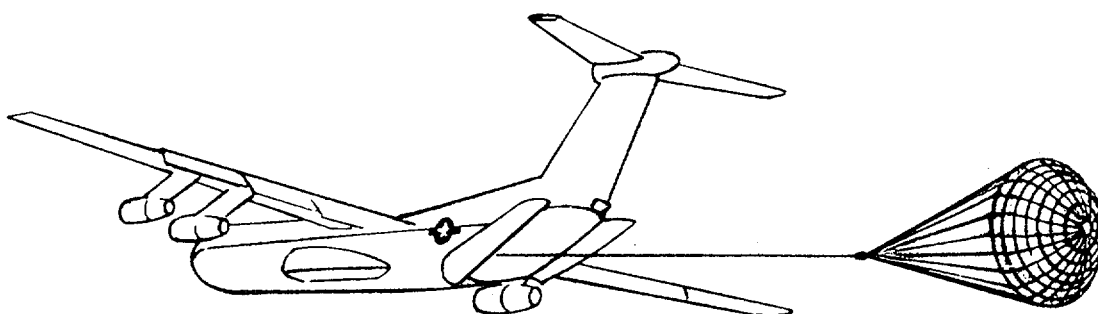

4728-001

*Figure 1-1. 22-Foot Diameter, Cargo Extraction Parachute, Deployed.*

a. General.

(1) *Objective.* Methods of destruction used to inflict damage on air delivery platforms should make it impossible to restore equipment to a usable condition in a combat zone by either repair or cannibalization.

(2) *Authority.* Destruction of air delivery equipment that is in imminent danger of capture by an enemy is a command decision that must be made by a battalion or higher commander or the equivalent.

(3) *Implementation plan.* All units which possess air delivery equipment should have a plan for the implementation of destruction procedures.

(4) *Training.* All personnel who use or perform such functions as rigging, packing, maintenance, or storage of air delivery equipment should receive thorough training on air delivery equipment destruction procedures and methods. The destruction methods demonstrated during training should be simulated. Upon completion of training, all applicable personnel should be thoroughly familiar with air delivery equipment destruction methods and be capable of performing destruction without immediate reference to any publication.

(5) *Specific methods.* Specific methods of destroying Army materiel to prevent enemy use shall be by mechanical means, fire or by use of natural surroundings.

b. Destruction by Mechanical Means. Air delivery equipment metal assemblies, parts, and packing aids shall be destroyed using hammers, bolt cutters, files, hacksaws, drills, screwdrivers, crowbars, or other similar devices to smash, break, bend or cut.

**WARNING**

Exercise extreme care when using petroleum products to destroy equipment by fire, as severe burns or death could result.

c. Destruction By Fire. Items that can be destroyed by fire shall be burned. The destruction of equipment by use of fire is an effective method of destroying low-melting-point metal items (e.g., side rails, threaded portions of nuts and bolts, and platform panels.) However, mechanical destruction should be completed first, whenever possible, before initiating destruction by fire. When items to be destroyed are made of metal, textile materials (or some comparable low combustible material) should be packed under and around the items, then soaked with a flammable petroleum product and ignited. Proper concentration of equipment which is suitable for burning will provide a hotter and more destructive fire.

d. Destruction By Use of Natural Surroundings. Small vital parts of assemblies which are easily accessible may be disposed of as follows: Disposal or denial of equipment to an enemy may be accomplished through use of natural surroundings. Accessible vital parts of assemblies may be removed and scattered through dense foliage, buried in dirt or sand, or thrown into a lake, stream, or other body of water. Total submersion of equipment in a body of water will provide water damage as well as concealment. Salt water will inflict extensive damage to air delivery equipment.

**1-4. Preparation for Storage or Shipment.** For storage, refer to TM 10-1670-201-21 T.O. 13C-1-41/NAVAIR 13-1-17, and Chapter 2, Section VII of this manual.

**1-5. Reporting of Equipment Improvement Recommendations (EIR).** If your parachute system needs improvement, let us know. Send us an EIR. You, the user, are the only one who can tell us what you don't like about your equipment. Let us know why you don't like the design or performance. Put it on an SF 368 Quality Deficiency Report (QDR). Mail it to us at: Commander, U.S. Army Troop Support Command, ATTN: AMSTR-QP, 4300 Goodfellow Blvd., St. Louis, MO 63120-1798. We will send you a reply.

**Section II. EQUIPMENT DESCRIPTION AND DATA**

<b>Paragraph</b>		<b>Page</b>
1-6	Equipment Characteristics, Capabilities, and Features .....	1-4
1-7	Location and Description of Major Components .....	1-4
1-8	Difference Between Models .....	1-7
1-9	Equipment Data .....	1-7
1-10	Safety, Care and Handling .....	1-8

**1-6. Equipment Characteristics, Capabilities, and Features.** A summary of the characteristics, capabilities and features of the equipment is contained in the following subparagraphs.

- a. Characteristics. Provides a capability to extract air delivery loads from an aircraft.
- b. Capabilities and Features.
  - (1) Alternate parachute for 26-foot high-velocity parachute.
  - (2) Used with the C-130 and C-141 aircraft.

**1-7. Location and Description of Major Components.** The following subparagraphs contain locations and descriptions of major components.

- a. Canopy. The canopy (figure 1-2) is a 22-foot-diameter flat circular ring slot canopy constructed with seven concentric rings of nylon fabric which are supported by 28 radial webs. There are 28 suspension lines which are attached on one end to the canopy. The opposite end of the suspension lines are connected to six detachable connector links which connect to the adapter web. The adapter web and extraction line are connected together by the type IV quick release link.

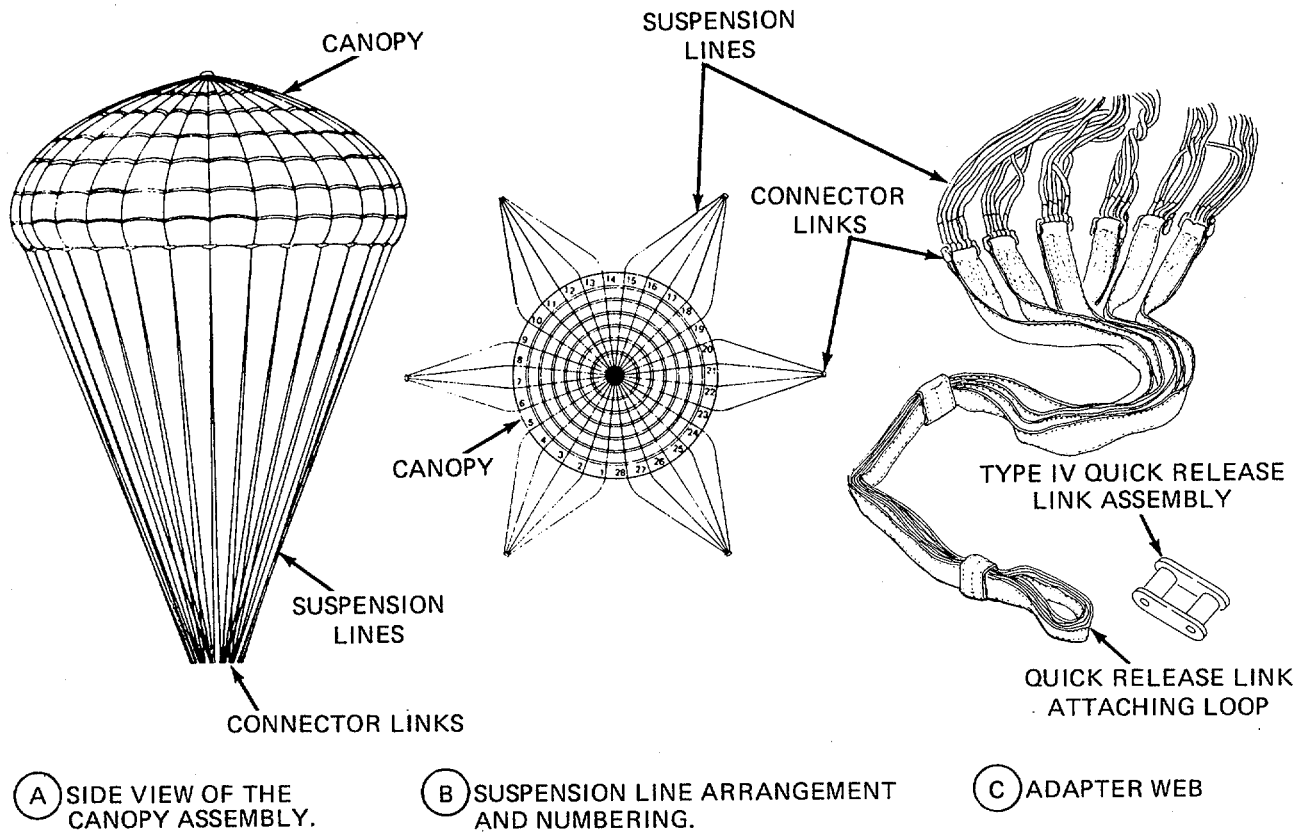

Figure 1-2. Canopy Assembly and Adapter Web.

1-7. Location and Description of Major Components (cont).

b. Extraction Line. The extraction line (figure 1-3) is a 60-foot long nylon web line constructed with three release knives, and one V-ring line.

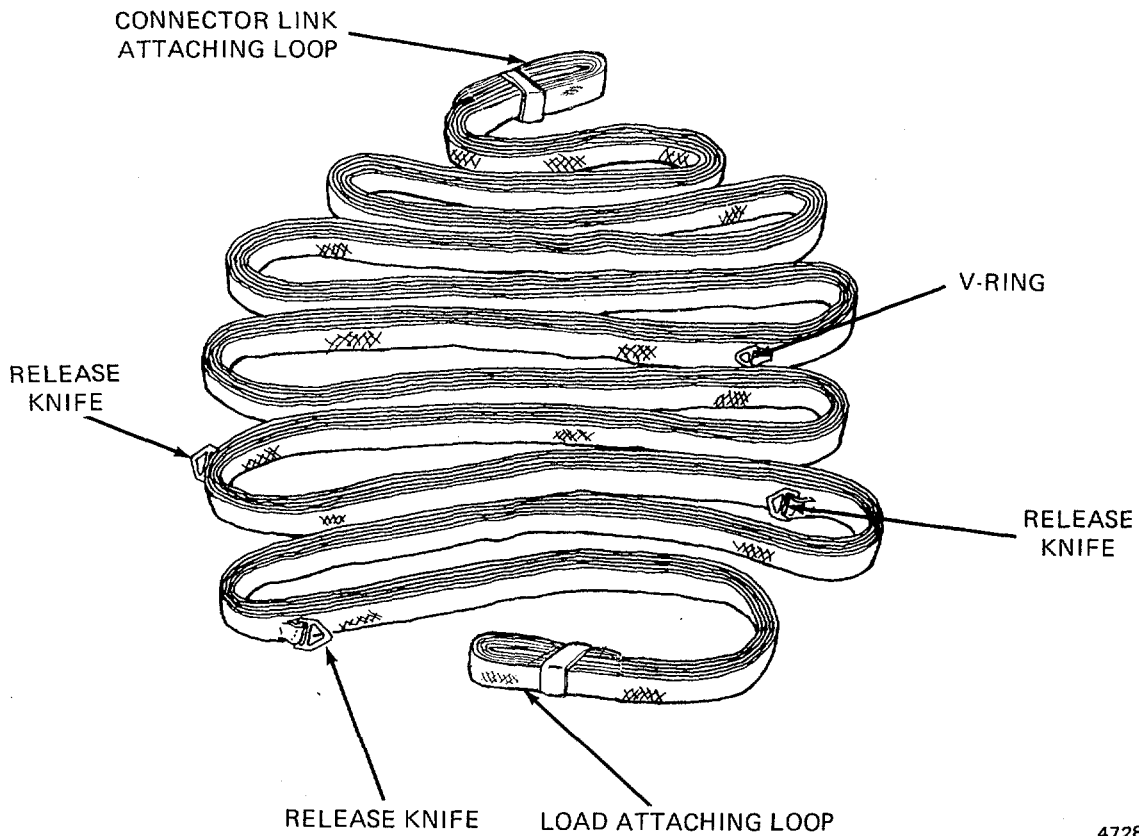
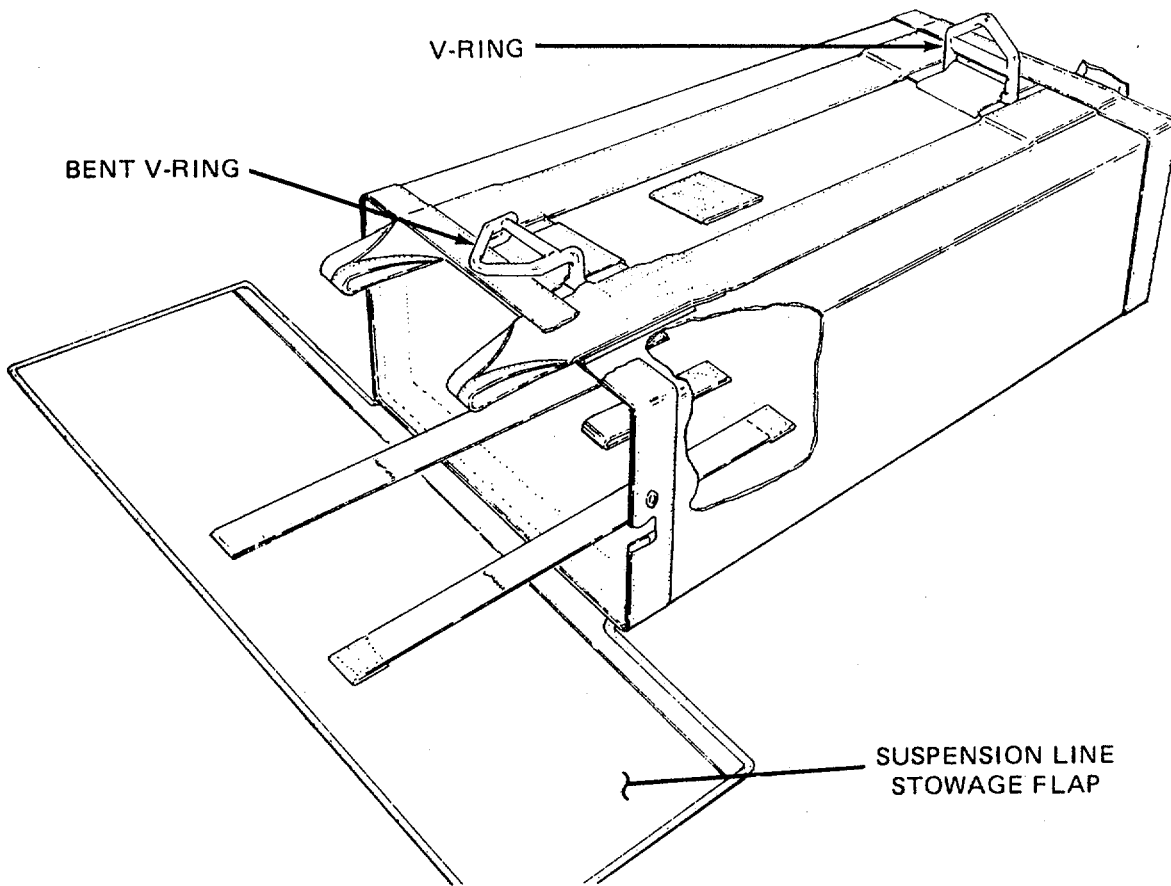

Figure 1-3. Extraction Line.

c. Deployment Bag. The deployment bag (figure 1-4) is used to stow the parachute and is constructed with one bridle loop, one V-ring, one bent V-ring and a suspension line stowage flap. The deployment bag is secured to the canopy with a retaining tie.





4728-004

Figure 1-4. Deployment Bag.

**1-8. Difference Between Models.**

NSN	Difference
1670-01-063716	XXVI Adapter Web
1670 00-687-5458	Type X Adapter Web with Type X Extraction Line

**1-9. Equipment Data.** The following listing summarizes the specific capabilities and limitations of the equipment and other critical data needed by the organizational and direct support (DS) maintenance personnel for maintenance of the 22-Foot Cargo Extraction Parachute Assembly.

a. General:

- (1) Total weight (packed for use) .....31161 pounds
- (2) Dimensions (packed for use) .....24-inches long by 18inches wide by 8inches high
- (3) Cube .....2 cu. ft

**1-9. Equipment Data (cont).**

*b. Assembly Specifics:*

(1) *Canopy assembly.*

Shape .....	Flat-circular
Diameter .....	22-ft
Design .....	Ring slot
Number of gores .....	28
Number of sections per gore .....	7
Gore material .....	Type II, 3.5-ounce Nylon
Number of vent lines .....	14
Number of suspension lines .....	28
Suspension line material .....	Type V coreless nylon cord
Suspension line length (from connector link to lower lateral band) .....	22 ft
Canopy length (from lower lateral band to upper lateral band) .....	10 ft
Number of pocket bands .....	28
Number of connector links .....	6

(2) *Deployment bag.*

Pendulum line material .....	Type IV coreless nylon cord
Pendulum line length .....	85 inches (cut length)

(3) *Extraction line.*

Length .....	60 ft
Number of plies .....	2
Number of release knives .....	3

(4) *Adapter web*

Length .....	5 ft
Number of plies .....	6

**1-10. Safety, Care, and Handling.**

*a. Safety.* It is imperative that you observe all safety precautions specified on the warning page in the front of this manual. You must also observe specific warnings and cautions specified throughout this manual. The warnings are provided to tell you how to protect yourself from death or serious injury.

*b. Care and Handling.*

(1) Use care in handling packed parachutes as metal parts can cause personal injury.

(2) Remove all jewelry when packing or performing maintenance on the parachute. Damage to the canopy materials could result from watches, rings, bracelets, etc.

- (3) Use every effort to protect the parachute from the weather elements, dust, dirt, oil, grease, acids, and direct sunlight.
- (4) Cover canopy during periods of inactivity. Avoid exposing canopy to prolonged exposure to sunlight, inspection lights or fluorescent lights. Nylon material is subject to deterioration under ultraviolet light.
- (5) Use a heated building to store parachutes when available. Store parachute in a dry, well ventilated location, protected from pilferage, dampness, fire, dirt, insects, rodents, and direct sunlight.



CHAPTER 2

UNIT AND INTERMEDIATE DIRECT SUPPORT (DS)  
 MAINTENANCE INSTRUCTIONS

	Page
Section I Repair Parts, Special Tools, TMDE, and Support Equipment .....	2-1
Section II Service Upon Receipt .....	2-2
Section III Assembly .....	2-10
Section IV Preventive Maintenance Checks and Services.....	2-11
Section V Unit and Intermediate Maintenance Procedures.....	2-15
Section VI Repair.....	2-50
Section VII Preparation for Storage or Shipment.....	2-131

**OVERVIEW**

This chapter contains information necessary to maintain the 22-Foot Diameter Cargo Extraction Parachute on the unit and intermediate direct support (DS) maintenance levels in accordance with the Maintenance Allocation Chart for the equipment. It includes the following:

- a. Procedures for processing a new or used parachute assembly upon receipt.
- b. Assembly of components prior to packing.
- c. Preventive maintenance procedures to ensure continued serviceability of all components.
- d. As-required inspections and maintenance procedures performed prior to packing such as shakeout and airing, cleaning and drying, and acidity and salt-water contamination tests.
- e. Detailed packing procedure.
- f. Repair methods and repair or replacement procedures for all components of the parachute assembly.

**Section I. REPAIR PARTS, SPECIAL TOOLS, TEST, MEASUREMENT  
 AND DIAGNOSTIC EQUIPMENT (TMDE), AND SUPPORT EQUIPMENT**

Paragraph		Page
2-1	Common Tools and Equipment .....	2-1
2-2	Special Tools, TMDE and Support Equipment.....	2-1
2-3	Repair Parts .....	2-1

**2-1. Common Tools and Equipment.** For authorized common tools and equipment, refer to the Modified Table of Organization and Equipment (MTOE) applicable to your unit and Appendix B, Section III of this manual.

**2-2. Special Tools, TMDE and Support Equipment.** Special Tools, TMDE and Support Equipment are not required.

**2-3. Repair Parts.** Repair parts are listed and illustrated in Appendix C of this manual.

**Section II. SERVICE UPON RECEIPT**

Paragraph	Page
2-4 Initial Receipt .....	2-2
2-5 Receipt of Used Parachute .....	2-7
2-6 After-Use Receipt .....	2-7
2-7 Checking Unpacked Equipment After Shipment .....	2-7

**2-4. Initial Receipt.** The following describes the procedures for processing parachutes upon initial receipt.

a. General Procedures for the 22-Foot Diameter Cargo Extraction Parachute. When air delivery equipment is initially procured from a supply source and issued to a using unit, the item(s) will be unpacked from the shipping container(s) and inspected by a qualified parachute rigger (MOS 43E). The inspection performed will be a technical/rigger-type which will be conducted as outlined in paragraph 2-13. Upon completion of the inspection, the item(s) will be tagged as prescribed in DA PAM 738-751. Serviceable equipment may then be entered either into storage or into use in air delivery operations, as applicable. An unserviceable item will be held and reported in accordance with DA PAM 738-750.

b. Inspection Personnel. Personnel other than parachute rigger personnel may assist in the unpacking process of initially received parachutes as directed by the local air delivery equipment maintenance officer. However, the maintenance officer will ensure that the entire unpacking effort is conducted under the direct supervision of a qualified rigger (MOS 43E).

c. Configuration/Condition. Acceptance of new equipment from the manufacturer is based upon inspections made of sample lots which have been randomly selected in accordance with military standards. It is incumbent upon the using activity personnel to bear this in mind whenever equipment is first placed in service. Changes will sometimes evolve from the original equipment design and sometimes contractors are authorized deviations in material and construction techniques. Air delivery equipment that has been in the field cannot be expected to meet exacting manufacturing specifications; however, the equipment should closely reflect desired design characteristics. Since repairs, modifications, and/or changes can alter or detract from the configuration originally desired, such equipment shall be airworthy, safe, of the desired configuration, and adequate for intended use.

d. Parachute Log Record. The Army Parachute Log Record DA Form 10-42 or DA Form 3912 is a history-type maintenance document which accompanies the parachute canopy and deployment bag assemblies through the period of service of the individual assembly. The log record provides a means of recording maintenance actions performed on a parachute canopy assembly. Normally, a log record is initiated and attached to a deployment bag upon receipt by a using unit. However, if the item is subjected to alteration or modification by a maintenance activity during the interim period from date of manufacture to receipt by a using unit, the log record will be prepared by the activity performing the maintenance function. Once initiated, a log record will be attached to and contained in an affixed parachute log record/inspection data pocket until such time as the parachute canopy assembly is destroyed or rendered unfit for further use or repair. Additionally, should an item that requires a log record be transferred from one unit to another, the log record for the parachute assembly will accompany the item in the transfer action. A prepared log record will not be removed or separated from a parachute, and especially a packed parachute, except as directed by the local air delivery equipment maintenance activity officer. A log record which is illegible, lost, damaged, soiled, or precludes further entries due to lack of space will be replaced upon the next repack or inspection, as applicable, with a serviceable item from stock.

e. Installing Attaching Tie. Install attaching tie as follows:

- (1) Cut a 30-inch length of ticket No. 8/7 waxed cotton thread (Item 25, Appendix D) and double thread length to form a 15-inch length, double strand.
- (2) Pass looped end of doubled thread length around centerfold of log record and form a slip loop on outside at log record top (A, figure 2-1).
- (3) Pass thread length running ends through corner attaching hole from front cover of log record (B, figure 2-1) and ensure running ends are routed over that part of thread length located along log record centerfold (C, figure 2-1).
- (4) Complete attachment tie by making a half hitch on top of slip loop made in (2) above.
- (5) Thread one running end of the log record attachment tie in a tacking needle and pass tacking needle with attached thread end through the edge binding of the applicable parachute log record/inspection data pocket.
- (6) Remove thread end from tacking needle and make a finished 10-inch long log attaching loop by securing two thread ends together with an overhand knot.
- (7) Insert log record into the pocket and secure the record within pocket using pocket flap and applicable type flap fastener.

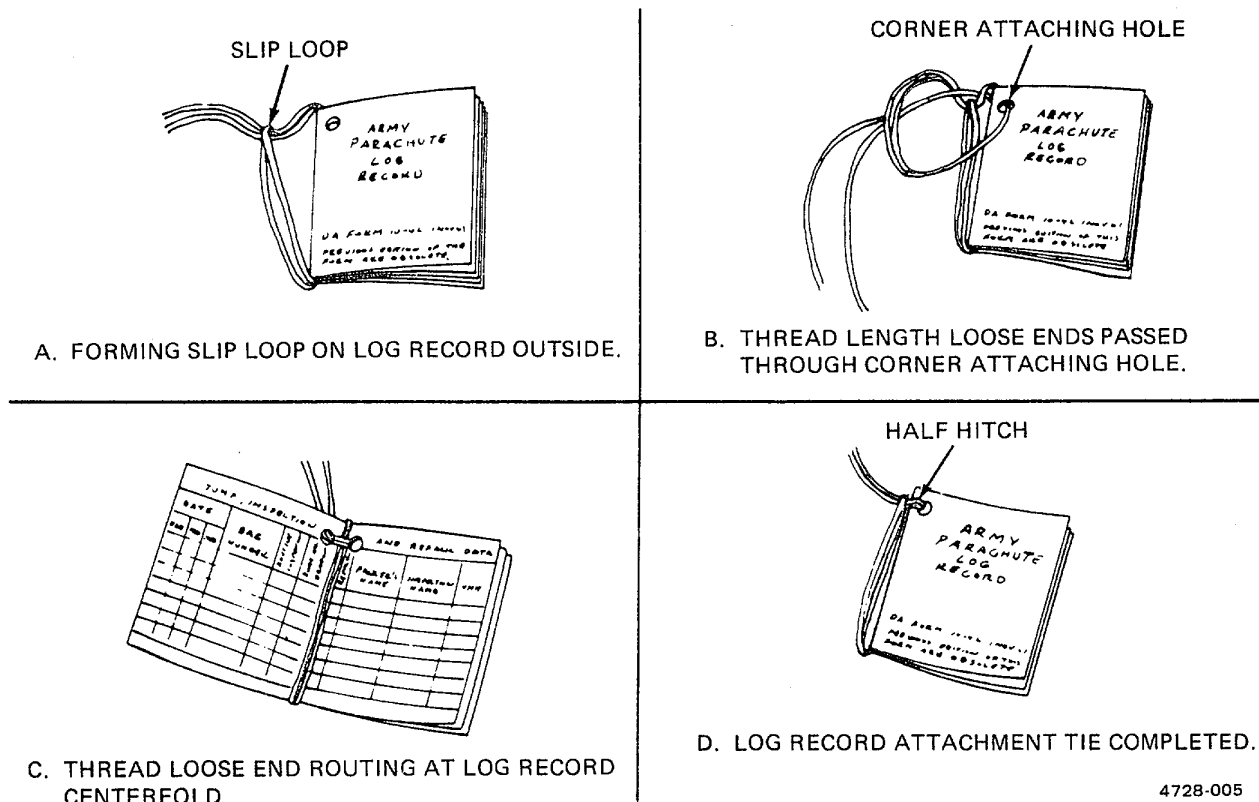

Figure 2-1. Installing Attachment Tie on Parachute Log Record.

4728-005

## 2-4. Initial Receipt (cont).

f. *Accomplishing a Log Record.* Upon completion of first technical/rigger-type inspection, the individual performing the inspection will initially prepare a log record for an individual parachute or applicable type parachute harness and accomplish subsequent record entries using the following procedures:

### NOTE

Log record book entries will be made with a suitable type blue or black marking device that cannot be erased.

(1) *Inside front cover.* Using the information provided on the parachute canopy data block, make the following entries on the inside front cover of the log record (figure 2-2). Entries may be continued on the inside of the back cover, if necessary.

### NOTE

A parachute canopy serial number is recorded in a log record as a method of establishing control for maintenance, EIR and QDR documentation, and to ensure the correct original record is reattached should the record become detached. A canopy serial number will not be used for property accountability, except in test projects or other special instances.

(a) *Serial number.* Enter parachute canopy assembly serial number.

SERIAL NO.	○
TYPE	
PART NO.	
DATE OF MFG. (Month & Year)	
MANUFACTURER	
CANOPY CONTRACT NO.	
STATION & UNIT	
<i>(Continued on inside back cover)</i>	

4728-006

Figure 2-2. Inside Front Cover of Parachute Log Record.

(b) *Type.* Enter parachute type.

(c) *Part number.* Enter part number of parachute canopy.

(d) *Date of manufacture.* Enter month and year parachute canopy was manufactured.

(e) *Manufacturer.* Enter name of parachute canopy manufacturer.



(f) *Canopy contract number.* Enter entire contract number specified for parachute canopy.

(g) *Station and unit.* Enter name of station and unit to which parachute canopy is currently assigned. When a parachute is transferred permanently to another station and/or unit original entry will be lined out and name of the receiving station and/or unit will be entered.

(2) *Inside back cover.* Entries may be continued on the inside back cover, if necessary (figure 2-3).

4728-007

Figure 2-3. Inside Back Cover of Parachute Log Record.

(3) *Modification work order compliance record page.* When a modification is performed on a parachute canopy, the following entries will be made on the "Modification Work Order Compliance Record" pages of the Log Record (figure 2-4).

MODIFICATION WORK ORDER		COMPLIANCE RECORD					
MWO NUMBER	MWO TITLE	MODIFIED BY (Number)	INSP BY	UNIT	DATE		
					DAY	MO	YR
10-1670-279-24	ENLARGE ORIFICE	Evans	Rob	702	25	7	71
10-1670-279-24	ENLARGE ORIFICE	C/W	mod	702	25	10	72

1. MODIFICATION WORK ORDER COMPLIANCE COMPLETED.
2. MODIFICATION COMPLETED BY UNKNOWN DUE TO LOST ORIGINAL LOG RECORD.

4728-008

Figure 2-4. Log Record Entries for the Modification Work Order Compliance Record Page.

(a) *MWO number.* Enter publication number and date of Modification Work Order (MWO) which describes MWO (1, figure 2-4).

(b) *MWO title.* Enter a short, abbreviated title extracted from MWO prescribing work.

**2-4. Initial Receipt (cont).**

(c) *Modified by.* Enter last name of individual who has performed the modification. If original log record for parachute has been lost, and it has been ascertained through inspection that a particular modification has been accomplished, entry for this column will be C/W "Complied With" (2, figure 2-4), which signifies applicable MWO has been complied with.

(d) *Inspected by.* The individual who accomplished the inspection required after modification will sign this entry with his last name only.

(e) *Unit.* Enter the unit designation responsible for performing the MWO or in the event of a lost Log Record, the unit to which the inspector is assigned.

(f) *Date.* Enter the day, month, and year the modification work was completed.

(4) *Unit and intermediate repair and inspection data.* When a parachute canopy assembly is initially received from a supply source and a technical/rigger-type inspection is performed, the inspection accomplishment will be documented on the "Unit and Intermediate Repair and Inspection Data" page of the individual Parachute Log Record (figure 2-5). Additional entries will also be made on this page each time the canopy assembly is repaired or is administered an inspection in compliance with a one-time inspection Technical Bulletin (TB). The page completion criteria is as follows:

(a) *Type of repair.* Enter the type of repair, completion of initial inspection, repair accomplishment, Technical Bulletin inspection compliance.

(b) *Inspection by.* The individual who accomplished the inspection required will sign this entry with last name.

(c) *Unit.* Enter the unit designation responsible for performing the type of repair.

(d) *Date.* Enter the day, month and year the repair was performed.

UNIT & INTERMEDIATE		REPAIR & INSPECTION DATA			
TYPE OF REPAIR		INSP BY	UNIT	DATE	
				DAY	MO
1	INITIAL INSPECTION	Boff	7th Cav	2	87
2	2 SEC and 4 Lines RIGGED	Evans	7th Cav	3	87
3	TB 10-1670-213-2915	Molloy	7th Cav	4	87

1. COMPLETION OF INITIAL INSPECTION.
2. REPAIR ACCOMPLISHMENT.
3. TECHNICAL BULLETIN INSPECTION COMPLIANCE

4728-009

Figure 2-5. Log Record Entries for Unit and Intermediate Repair and Inspection Data Page.

(5) *Note page.* A page is provided at the back of a parachute log record to accommodate recording of additional data pertinent to the serviceability of a parachute canopy assembly (figure 2-6). This shall also include the month and year the item was placed in service.

NOTES

RISER MFG. DATE: JAN. '86  
PLACED IN SERVICE: MAR. '86  
IMMERSED IN SALT WATER: 26/10/86  
RINSED 27/10/86

4728-010

Figure 2-6. Data Entries for a Log Record Note Page.

**2-5. Receipt of Used Parachute.** Upon initial receipt of used parachute proceed as follows:

- a. Follow procedures given in paragraph 2-4a, and check each component for excessive wear and tear.
- b. If defects or damages are discovered, process the parachute for maintenance at the maintenance level assigned by the Maintenance Allocation Chart (Appendix B).

**2-6. After-Use Receipt.** When a parachute is received at the maintenance activity following its use during airdrop, it must be given a shakeout and aired (para 2-11), and if necessary, cleaned (para 2-12) before it can be returned to service. If a parachute is issued but is not used, it does not need to be given a shakeout; however, it must be aired if it has been subjected to conditions of dampness.

**2-7. Checking Unpacked Equipment After Shipment.**

- a. Inspect equipment for damage incurred during shipment. If the equipment has been damaged, report the damage on SF Form 364, Report of Discrepancy (ROD).
- b. Check the equipment against the packing slip to see if the shipment is complete. Report all discrepancies in accordance with the instructions in AR 735-11-2, Reporting of Item and Packaging Discrepancies.
- c. Check to see whether the equipment has been modified.

**Section III. ASSEMBLY**

Paragraph		Page
2-8	Assembly of the 22-Foot Diameter Cargo Extraction Parachute .....	2-8

---

**2-8. Assembly of the 22-Foot Diameter Cargo Extraction Parachute.**

---

This task covers:            Assembly

---

*Personnel Required:*

43E (10) Parachute Rigger

*Equipment Condition:*

Parachute on packing table

---

**NOTE**

The procedure for assembling components of the parachute is incorporated in the Packing Procedure, paragraph 2-16.

All data on this page including Figure 2-7 is deleted.

**Section IV. PREVENTIVE MAINTENANCE CHECKS AND SERVICES (PMCS)**

<b>Paragraph</b>	<b>Page</b>
2-9 PMCS Procedures.....	2-10

**2-9. PMCS Procedures.** The following describe PMCS procedures on the unit and intermediate direct support (DS) levels.

a. General. Table 2-1 lists preventive maintenance checks and services. The purpose of PMCS is to ensure that the 22-foot diameter cargo extraction parachute is operational.

b. Frequency of Performing PMCS. PMCS will be performed before equipment is packed for use, during modification and repair after use, or at any time deemed necessary by the air delivery equipment maintenance officer.

c. PMCS Columnar Entries, Table 2-1. Enter data in columns as follows:

(1) Item number. The item number column shall be used as a source of the item number required for the "TM Number" column on DA Form 2404 (Equipment Inspection and Maintenance Worksheet) when recording the results of PMCS.

(2) Interval. This column identifies the required PMCS interval.

(3) Item to be inspected. Contains the common name of the item to be inspected.

(4) Procedures. Provides a brief description of the procedure by which the checks are to be performed.

d. Recording Defects. All defects discovered during the inspection will be recorded using the applicable specifics in DA PAM 738-750, DA PAM 738-751, and TB 43-0002-4.

e. Overage Items. The 22-foot cargo extraction parachute has no age or service life.

f. Inspection Function Requirement. Normally, a technical/rigger-type inspection will be performed by air delivery equipment maintenance personnel at a packing, rigging, or repair activity. The inspection of initial receipt items will be performed as a separate function from packing or rigging activity; the item to be inspected will be placed in proper layout on packing table or suitable sized floor area. Should defects or damage be discovered at any point during the inspection, the inspection will be terminated and the applicable item will be processed and forwarded to a repair activity. The repair activity, in turn, will conduct a technical/rigger-type inspection that will be performed by only those parachute rigger personnel cited in AR 750-32 Airdrop Parachute Recovery and Aircraft Personnel Escape Systems. The repair activity inspection of small cargo parachutes will be made on a shadow table. Any defect discovered during a unit level repair activity inspection which exceeds the capability of that activity will require the affected item to be evacuated to an intermediate direct support (DS) maintenance function for further determination of economic repair and repair accomplishment, if applicable.

**NOTE**

Parachutes which are deemed unserviceable by a packing or rigging activity will be rigger-rolled prior to being sent to a repair activity.

Table 2-1. Unit and Intermediate Direct Support (DS) Preventive Maintenance Checks and Services (PMCS).

B - Before

D - During

A - After

Item No.	Interval			Item to be inspected	Procedures
	B	D	A		
					<b>NOTE</b>
				The 22-Foot Diameter Cargo Extraction Parachute	Any defective material noted must be repaired prior to use. If the Type X 60-ft. extraction line is found defective, it will be replaced with the 5-ft. adapter web.
1	●		●	Parachute Packed for Use	Visually check visible parts for serviceability and completeness without opening pack. Check parachute inspection data record for pack date.
2	●		●	Canopy	As canopy is raised, suspended, and lowered during shakeout, check for dampness, fungus, acid, grease, oil, dirt, foreign material, holes, cuts, tears; broken lines and webbing.
	●		●	Fabric Material	Legibility of marking data; completeness; dampness, fungus, dirt, acid, grease, oil, foreign material, rips, burns, cuts, breaks, frays, tears, holes, thin spots, loose weaving; loose or broken stitching, lines, and webbing.
	●		●	Hardware Components	Corrosion, rough spots, burrs, breaks, cracks, bends; loose or missing screws.
3	●		●	Deployment Bag	Completeness; dampness, fungus, acid, grease, oil, dirt, foreign material, holes, cuts, and breaks.
	●		●	Fabric Materials	Completeness; dampness, fungus, dirt, acid, grease, oil, foreign material, rips, burns, cuts, breaks, frays, tears, holes; loose or broken stitching.
	●		●	Hardware Components	Corrosion, rough spots, breaks, cracks, bends; loose or missing grommets.

Table 2-1. Unit and Intermediate Direct Support (DS) Preventive Maintenance Checks and Services (PMCS) (cont).

Item No.	Interval			Item to be inspected	Procedures
	B	D	A		
4	●		●	Extraction Line (60-Foot Long)	Completeness, dampness, fungus, acid, grease, oil, dirt, foreign material, holes, cuts, or breaks.
	●		●	Fabric Materials	Completeness, dampness, fungus, acid, grease, oil, foreign material, burns, cuts, breaks, frays, tears; loose or broken stitching.
	●		●	Hardware Components	Corrosion, rough spots, breaks, cracks, and bends; unused V-rings and release knives taped.
5	●		●	Type IV Link Assembly	Completeness; rust, corrosion, rough spots, breaks, burrs, cracks, and operation.
6	●		●	5-Foot Long Extraction Parachute Adapter Web	
	●		●	Webbing Length	Dampness, fungus, acid, grease, oil, dirt, foreign material, cuts, burns, frays, missing keeper, loose or broken stitching.
	●		●	Attaching Loops	Damaged or missing buffers, loose or broken tacking.

**Section V. UNIT AND INTERMEDIATE DIRECT SUPPORT (DS) MAINTENANCE PROCEDURES**

Paragraph		Page
2-10	General Information .....	2-13
2-11	Shakeout and Airing .....	2-14
2-12	Cleaning and Drying .....	2-16
2-13	Inspection .....	2-20
2-14	Acidity Test .....	2-23
2-15	Salt-Water Contamination Test .....	2-24
2-16	Packing the 22-Foot Cargo Extraction Parachute .....	2-25



**2-10. General Information.** The following paragraphs contain general information pertinent to unit and intermediate direct support (DS) maintenance procedures.

a. Scope. This section contains maintenance procedures which are the responsibility of the specified technician as authorized by the Maintenance Allocation Chart (MAC) and the Source, Maintenance and Recoverability (SMR) coded items that are identified in the repair parts and special tools list (RPSTL).

b. Maintenance Functions/Procedures. Each paragraph identifies a maintenance function specified in the MAC. All maintenance procedures required to complete a maintenance function are identified under "This task covers:", in the order in which the work is most logically accomplished.

---

## 2-11. Shakeout and Airing.

---

This task covers:      a. Shakeout                      b. Airing

---

*Tools:*

Brush, Scrub, Household, Item 1, Appendix B

*Equipment Condition:*

Parachute Suspended

*Personnel Required: (2)*

43E(10) Parachute Rigger

---

a. *Shakeout.* The shakeout will be accomplished by a two-person team, either indoors within a shakeout room or outdoors at a shakeout tower. Each parachute will be suspended by the canopy vent and all debris removed by shaking the canopy thoroughly or by brushing with a dry soft-bristled brush as detailed below:

- (1) With assistance from No. 2 person, No. 1 person will connect snap on a pulley rope to canopy bridle loop (A, figure 2-8).
- (2) Through use of pulley rope, No. 2 person will raise canopy to a suitable height which will enable No. 1 person to perform shakeout on each of canopy gores. Until gore shaking process is completed, No. 2 person will maintain a steady pull on pulley rope to hold suspended canopy at working height needed by No. 1 person.
- (3) No. 1 person will grasp any two consecutive suspension lines, one in each hand (B, figure 2-8), and vigorously shake first gore. When gore is free of debris, No. 1 person passes line from right hand to left hand and grasps next consecutive suspension line in right hand. No. 1 person will shake out each consecutive gore until all suspension lines are held in left hand and all gores are free of debris.
- (4) Once gore shaking process is completed, No. 2 person will slowly raise suspended canopy higher as No. 1 person clears suspension lines of debris and removes entanglements (C, figure 2-8) when possible.
- (5) After suspension lines have been cleared, No. 2 person may hold or temporarily secure pulley rope while No. 1 person proceeds to clear debris from other parachute components.
- (6) When all components are free of debris, No. 2 person will slowly lower canopy while No. 1 person S-folds suspension lines into deployment bag (D, figure 2-8). After suspension lines have been completely folded, No. 1 person will accordion-fold canopy length on top of folded lines.
- (7) As canopy folding is being completed, No. 1 person disconnects canopy vent from pulley rope snap. Secure folded canopy assembly for further handling.

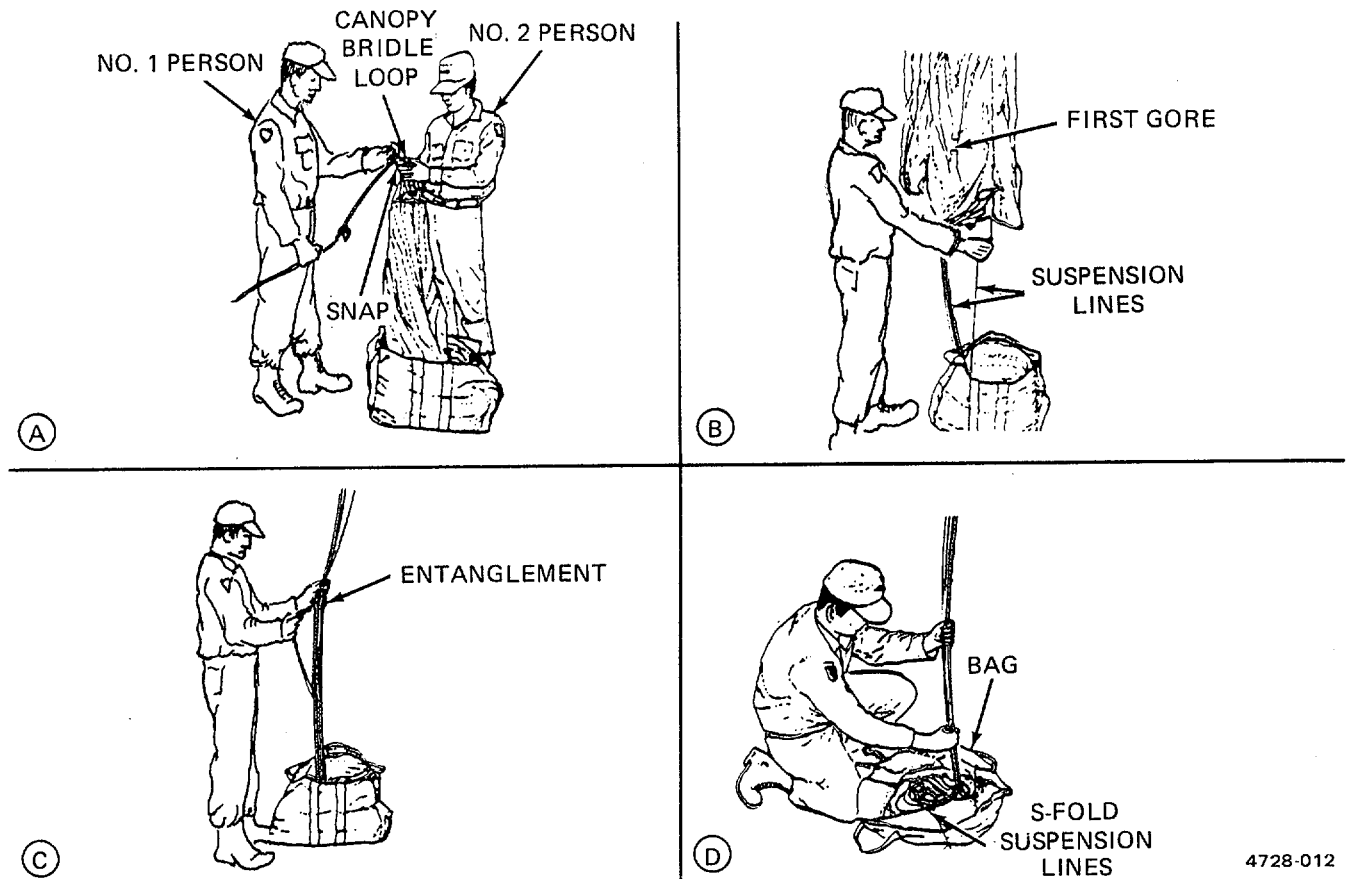

Figure 2-8. Shakeout.

**CAUTION**

Prolonged exposure to direct sunlight will cause extensive damage to fabric materials.

b. *Airing.* Where dampness and mildew are common, air delivery equipment will be aired at a more frequent interval. Parachutes that have been previously packed or are unpacked, which have been subjected to conditions of dampness or mildew, will be aired for a period of at least 6 hours prior to being repacked. Air delivery items may be aired either indoors or outdoors in dry weather. However, fabric items will not be aired in direct sunlight. Airing may be accomplished by suspending or elevating the applicable item(s) in a manner which would allow entire exposure to the circulation of air. Outside facilities used for the shakeout of parachutes may be used for the airing of air delivery equipment if weather conditions permit. If the shakeout facilities are inadequate for airing, the applicable item(s) may be suspended or elevated at several points or by draping over suitable type objects which would not cause damage.

## 2-12. Cleaning and Drying.

---

- This task covers:
- |  |                                      |
|--|--------------------------------------|
| a. Cleaning fabric items with cleaning solvent     | c. Drying fabric items               |
| b. Cleaning fabric items with dishwashing compound | d. Equipment immersed in salt water  |
|  | e. Equipment immersed in fresh water |
- 

*Tools:*

Brush, Scrub, Household, Item 1, Appendix B

*Equipment Condition:*

Layout on packing table or other suitable area.

*Materials/Parts:*

Tetrachloroethylene, Item 24, Appendix D  
Dishwashing Compound, Item 8, Appendix D  
Rag, Wiping, Item 17, Appendix D  
Lubricant, Solid Film, Item 10, Appendix D  
Cloth, Abrasive, Item 3, Appendix D  
Brush, Scrub, Item 1, Appendix B

*Special Environmental Condition:*

Ventilation required as repeated or prolonged inhalation of cleaning solvent vapors can be detrimental to human health.

*Personnel Required:*

43E(10) Parachute Rigger

---

**WARNING**

Due to flammable properties and nylon-damaging substances, cleaning solvents other than tetrachloroethylene will not be used in the spot-cleaning of air delivery equipment. Tetrachloroethylene will only be used in areas where substantial ventilation is available. Repeated or prolonged inhalation of the solvent vapors can be detrimental to human health. In addition, avoid prolonged or repeated contact of the solvent fluid with areas of the skin. Tetrachloroethylene must not be taken internally.

**CAUTION**

If during the cleaning there exists a possibility that the substance to be removed contains acid or some other equally destructive ingredient, the item will be evacuated to intermediate maintenance activity for determination as to the nature of the substance and item disposition. If the substance cannot be identified or if normal repair procedures will not eliminate all traces of chemical or acid damage, the applicable item will be condemned.

**NOTE**

Cleaning of parachutes should be held to a minimum and should be performed only when necessary to prevent malfunction or deterioration. When a parachute contains debris, or when it is soiled by dirt, oil, grease, rust, corrosion, or other foreign substances to such an extent that cleaning is necessary, the cleaning should be performed manually and should be limited to the soiled area only, unless the parachute has been contaminated by water. The methods of cleaning must be determined by the nature of the substance to be removed.

Do not use cleaning solvent to clean item soiling caused by air sickness. Use a solution of hand dishwashing compound to clean this type of soiling.

a. Cleaning Fabric Items with Cleaning Solvent. Use cleaning solvent to clean fabric items as follows:

- (1) Gently brush with a soft bristle brush.
- (2) Spot clean with cleaning solvent tetrachloroethylene.
  - (a) Rub soiled area with a clean cloth dampened with tetrachloroethylene.
  - (b) Rinse cleaned area by repeating the rubbing process with clean portion of cloth dampened with the cleaning solvent.

**NOTE**

Do not wring out the rinsed area if an excessive amount of cleaning solvent was applied.

b. Cleaning Fabric Items with a Solution of Hand Dishwashing Compound. Use dishwashing compound to clean fabric items as follows:

- (1) Gently brush with a soft bristle brush.
- (2) Spot clean with a solution of dishwashing compound.
  - (a) Dissolve 1/2 cup of dishwashing compound in one gallon of warm water.
  - (b) Rub soiled area with a clean cloth dampened with solution of dishwashing compound.
  - (c) Rinse cleaned area by repeating rubbing process with a clean portion of cloth dampened with the dishwashing compound.

**NOTE**

Fabric items will not be dried in direct sunlight or by laying an item on the ground.

**2-12. Cleaning and Drying (cont).**

c. Drying Fabric Items. Dry fabric items as follows:

- (1) Suspend or elevate item in a well-ventilated room or in a heated drying room.
- (2) Drying time may be reduced by using electric circulating fans.
- (3) When heat is used, the heat temperature shall not exceed 160°F (71°C). Preferred temperature is 140°F (60°C).

d. Cleaning Metal Items. Clean metal items as follows:

**CAUTION**

Use care not to damage the adjacent fabric materials.

- (1) Remove burrs, rough spots, rust or corrosion from metal items by filing with a metal file or by buffing and polishing with abrasive cloth.

**WARNING**

Use tetrachloroethylene only in areas where substantial ventilation is provided. Repeated or prolonged inhalation can be detrimental to human health. Avoid prolonged or repeated contact with skin areas. Tetrachloroethylene must not be taken internally.

- (2) Remove all oils and filings by brushing and dipping in tetrachloroethylene. Allow to dry.

**NOTE**

Shield adjacent fabric material before spraying solid film lubricant.

- (3) Spray metal item with a solid film lubricant and allow to air dry for 24 hours.

**NOTE**

A small amount of lubricant will not damage fabric, but may cause discoloration and make fabric appear soiled.

e. Equipment Immersed in Salt Water. Items found or known to be salt contaminated are to be cleaned within 48 hours after recovery in the following manner:

- (1) Place equipment in a large water-tight container filled with a suitable amount of fresh, clean water to cover item(s).

**CAUTION**

Equipment made of cotton fabric immersed in salt water are to be condemned. See paragraph 2-13e, for equipment disposition.

**NOTE**

If salt water-soaked equipment is too large to be placed into a rinsing container, then the rinsing process will be effected by applying fresh, clean water to the item using a hose.

- (2) Agitate container contents by hand for 5 minutes.
- (3) Remove item(s) from container and suspend or elevate equipment in a shaded area, allowing a 5-minute drainage period. Do not attempt to wring equipment fabric or, if applicable, suspension lines.
- (4) Repeat procedures in (1) through (3) above twice, using fresh, clean water for each rinse.
- (5) After third rinse, allow equipment to drain thoroughly. Upon completion of draining, dry equipment in accordance with procedures in paragraph 2-12c.
- (6) When dried, perform a technical/rigger-type inspection of item(s). Corroded metal components, or corrosion-stained fabrics or suspension lines will be either repaired or replaced as prescribed by Maintenance Allocation Chart (MAC) (Appendix B).
- (7) If recovered equipment is a parachute, record immersion, rinsing, and any repairs in individual parachute log record as outlined in paragraph 2-4f.

f. *Equipment Immersed in Fresh Water.* Any air delivery equipment that has been immersed in a fresh water lake, river, or stream will not require rinsing unless it has been ascertained that the water is dirty, oily, or otherwise contaminated. Procedures for handling a fresh water immersed item are as follows:

- (1) *Contaminated fresh water.* If air delivery equipment has been immersed in contaminated fresh water, rinse, dry, and, if applicable, repair the item(s) using the procedures in paragraph f above.
- (2) *Uncontaminated fresh water.* If air delivery equipment has been immersed in uncontaminated fresh water, item(s) will be cleaned and dried as outlined in this paragraph. Minor discoloration of fabric items resulting from immersion in uncontaminated fresh water may occur. No attempt should be made to eliminate a minor discoloration as a slight discoloring is preferable to employing vigorous techniques that may damage fabric. Small stains caused by petroleum products or blood will be removed using spot-cleaning procedures in paragraph 2-12a.

---

## 2-13. Inspection.

---

This task covers:

a. Routine	d. In-storage
b. Pack-in-Process	e. Equipment Disposition
c. Technical-Rigger-Type	

---

*Personnel Required:*

43E(10) Parachute Rigger

*Equipment Condition:*

Packed

---

*a. Routine Inspection.* A routine inspection is a visual check performed to ascertain the serviceability of all visible components of a parachute that is packed or rigged for use. The inspection will be made on all components that can be inspected without opening the parachute pack. This inspection will be administered by a parachute rigger prior to issue. Parachutes issued for an air delivery operation and not deployed will receive a routine inspection prior to being placed into ready-for-issue storage.

*b. Pack-in-Process Inspection.* A pack-in-process inspection is performed at specified intervals during the packing of a parachute to ensure that only authorized procedures and methods are being used. The inspection will be accomplished by a parachute rigger other than the packer or rigger preparing the applicable equipment for use. The intervals at which the inspection is performed is as follows:

- (1) After parachute is placed in proper layout.
- (2) After gores are folded and flatfold is completed.
- (3) After canopy is longfolded.
- (4) After canopy is stowed.
- (5) After suspension lines are stowed.
- (6) After deployment bag is closed.
- (7) After extraction line is stowed (if applicable).

*c. Technical/Rigger-Type Inspection Procedures.*

- (1) *Overall inspection.* An overall inspection will be made on the 22-foot cargo extraction parachute to ascertain the following:

- (a) Log record/parachute inspection data pocket and form.* As applicable, inspect assembly log record/parachute inspection data pocket to ensure the Army Parachute Log Record (DA Form 10-42 or 3912) is enclosed and properly attached as prescribed in paragraph 2-4f. Further, remove log record from pocket and evaluate recorded entries to ensure compliance with paragraph 2-4f.



(b) *Assembly completeness.* Ensure that applicable assembly is complete and no components or parts are missing.

(c) *Operational adequacy.* Check item components and parts to insure proper assembly which includes attachment and alignment, and that assembled product functions in prescribed manner. Further ensure that no stitch formation or sewn seam has been omitted.

(d) *Markings and stenciling.* Inspect each assembly and components for faded, illegible, obliterated, or missing informational data, identification numbers.

(e) *Foreign material and stains.* Inspect each assembly and related components for presence of dirt or similar type foreign material. Also check for evidence of mildew, moisture, oil, grease, pitch, resin, or contamination by salt water.

(2) *Detailed inspection.* In addition to the overall inspection performed in (1) above, a detailed inspection will be performed on materials which constitute assembly or component construction using following criteria, as applicable:

(a) *Metal.* Inspect for rust, corrosion, dents, bends, breaks, burrs, rough spots, sharp edges, wear, deterioration; damaged, loose, or missing screws.

(b) *Cloth.* Inspect for breaks, burns, cuts, frays, holes, rips, snags, tears; loose, missing, or broken stitching or tacking; weak spots, wear, or deterioration.

(c) *Fabric tape, webbing, and cordage.* Inspect for breaks, burns, cuts, frays, holes, snags, tears, incorrect weaving, and sharp edges formed from searing; loose, missing, or broken stitching, tacking, whipping, and weaving; weak spots, wear, and deterioration.

(d) *Pressure-sensitive (adhesive) tape.* Inspect for burns, holes, cuts, tears, weak spots, looseness and deterioration.

d. *In-Storage Inspection.* An in-storage inspection is a physical check conducted on a random sample of air delivery equipment which is located in storage. The purpose of the inspection is to ensure that the equipment is ready for issue, that the item is properly identified and segregated from other types of equipment, that no damage or deterioration of equipment has been incurred, and that all modifications or similar action requirements have been completed. The inspection shall also concern the methods and procedures applied to the storage of air delivery items, the adequacy of storage facilities, efforts of pest and rodent control, and protection against unfavorable climatic conditions. Air delivery equipment which is in storage will be inspected at least semiannually and at more frequent intervals if prescribed by the local parachute maintenance officer. The frequency of inspection may vary according to the type of storage facilities and local climatic conditions. In-storage inspection will be conducted only by parachute rigger personnel designated by local parachute maintenance officer.

e. *Equipment Disposition.* Air delivery equipment may be rendered unserviceable by either normal fair wear or by aging and will subsequently be repaired, modified, or condemned, as appropriate. Equipment that is uneconomically repairable (outdated) will be condemned. Disposition of air delivery equipment that is condemned, unserviceable, or for which the serviceability is questionable, will be accomplished using the following procedures, as applicable.

## 2-13. Inspection (cont).

(1) *Item requiring repair or modification.* An air delivery item which requires repair or modification will be tagged in accordance with DA PAM 738-751. Subsequent work on the item will be performed at the maintenance level specified for the maintenance function in the applicable supporting technical publication.

(2) *Parachutes with exhausted age or service life.* Any parachute component or air delivery equipment whose age or service life has expired as specified in TB 43-0002-4 will be removed from service, condemned and tagged as prescribed by DA PAM 738-751.

(3) *Disposition of condemned air delivery equipment.* Condemned equipment, other than fatality parachutes, will be removed from service and disposed of in accordance with current directives listed in Appendix A of this manual.

(4) *Rejected equipment.* Equipment which, prior to use, is deemed unserviceable for use will be reported in an EIR in accordance with DA Pam 738-750, as authorized by AR 750-1. Each applicable item which is defective will be held and safeguarded pending receipt of disposition Instructions from the National Maintenance Point (NMP). In all instances, EIR exhibit material will be handled as prescribed in DA Pam 738-750. If the quality or the serviceability of an item is questionable, clarification and assistance may be obtained by contacting Commander, US Army Troop Support and Aviation Materiel Readiness Command, ATTN: AMSTR-QT, 4300 Goodfellow Blvd., St Louis, Missouri 63120.

(5) *Equipment of doubtful serviceability.* Equipment which has had previous use and has not exceeded normal fair wear or aging criteria, but of which further serviceability is doubtful, will be tagged as prescribed in TB 750-126. In addition, the equipment will be reported in an EIR in accordance with DA Pam 738-750 and AR 750-1. The item(s) in question will be held as EIR exhibit material as outlined in DA Pam 738-750 pending receipt of disposition instructions from the NMP. A maintenance activity holding EIR exhibit material will not tamper with the applicable item(s) or make any attempt to ascertain cause factors. Unnecessary handling of EIR exhibit material may disturb or alter peculiar aspects of the affected item(s) which might affect the judgment of engineering personnel who have the responsibility for final evaluation of EIR actions.

(6) *Equipment immersed in salt water.* Any air delivery item constructed from cotton material that has been immersed in salt water will be condemned. Cotton thread used for tacking and sewing on nylon parachute packs which have been immersed in salt water will only be replaced when there is visible evidence of deterioration such as extreme discoloration or indications of broken thread. Any air delivery equipment constructed of nylon or rayon material that has been immersed in salt water in excess of 24 hours will be condemned. Additionally, any nylon or rayon air delivery item that has been immersed in salt water for a period less than 24 hours, but which cannot be rinsed within 48 hours after recovery will also be condemned. However, if the cited time limitations can be met, then immediately upon recovery, suspend or elevate the recovered equipment in a shaded area and allow the item(s) to drain for at least 5 minutes. Do not attempt to wring the equipment fabric or the suspension lines. Within 48 hours after recovery, under the supervision of a qualified parachute rigger (43E), rinse the recovered equipment as indicated in paragraph 2-12e.

---

## 2-14. Acidity Test.

---

This task covers:       Acidity test

---

*Tools:*

Packing Paddle, Item 10, Appendix B

*Personnel Required:*

43E(10) Parachute Rigger

*Materials/Parts:*

Medicine Dropper, Item 12, Appendix D  
Three-Color pH Paper, Item 13, Appendix D  
Spool with Color Chart, Item 18, Appendix D

*Equipment Condition:*

Unpacked.  
Layout on packing table or other suitable area.

---

*a. Fabric and Webbing Acidity Test.* Components and parts that are constructed from fabric or webbing will be administered an acidity test whenever the material is discolored, stained, or the presence of acid is suspected. The acidity test will be accomplished using approved colorimetric pH paper, strip type, with the color comparison chart on the side of each manufacturer's dispenser, to determine the acidity level in steps of 1 pH on a fabric or webbing item.

*b. Test Procedure.* Perform test as follows:

- (1) Using a medicine dropper or equivalent type applicator, place one to two drops of water on item in intended test area. If water drops do not penetrate material, gently rub moistened area with a flat side of a clean metal packing paddle.
- (2) Tear a suitable length of colorimetric pH paper from dispenser, place piece of pH paper on wetted area and press full surface of paper against material with a flat side of packing paddle used in step (1) above. Ensure the pH paper becomes thoroughly wet.
- (3) Using color comparison chart enclosed in dispenser, compare the color of moistened pH paper strip with the pH 1-3 color scale. If the color of the pH paper matches the numerical pH 1-3, the acidity present in the material exceeds the acceptable level and the item is to be condemned and processed for disposition in accordance with paragraph 2-13.
- (4) After a packing paddle has been used as outlined in steps (1) and (2), above, thoroughly rinse and dry the paddle before using the paddle for any other functions.

**2-15. Salt-Water Contamination Test.**

---

This task covers:        Inspection

---

*Personnel Required:*

43E (10) Parachute Rigger

*Equipment Condition:*

Layout on packing table or other suitable area.

---

**NOTE**

Clean or condemn equipment known or suspected of salt contamination in accordance with paragraph 2-12e and 2-13e.

*Inspection.* Look for a white crystalline residue.

## 2-16. Packing the 22-Foot Cargo Extraction Parachute.

---

This task covers:

- |   |  |
|---|--|
| a. Inspection   | h. Folding the Gores                                     |
| b. Orientation  | i. Longfolding the Canopy                                |
| c. Preparing Parachute for Proper Layout              | j. Stowing the Canopy                                    |
| d. Removing Inversion                                 | k. Stowing the Suspension Lines                          |
| e. Removing Partial Inversion                         | l. Closing the Deployment Bag                            |
| f. Locating Suspension Lines                          | m. Attaching the Extraction Line                         |
| g. Attaching and Stowing Deployment Bag Retaining Tie | n. Stowing Extraction Line, Adapter Web, or Release Line |
|   | o. Signing DA Form 10-42                                 |
- 

*Tools:*

Packing Weights, Item 11, Appendix B  
Line Separator, Item 7, Appendix B  
Packing Paddle, Item 10, Appendix B  
Knife, Item 4, Appendix B

*Materials/Parts:*

Retainer Band, Rubber, Item 1, Appendix D  
Webbing, Cotton, Type I, 1/4-in.,  
Item 33, Appendix D  
Tape, Pressure Sensitive, Item 23,  
Appendix D  
Cord, Nylon, Type V, Item 6, Appendix D

*Personnel Required:*

43E(10) Parachute Rigger

*References:*

TM 10-1670-201-23 T.O. 13C-1-41/  
NAVAIR 13-1-17  
DA PAM 738-751  
TB 43-0002-4

*Equipment Condition:*

Parachute cleaned (reference paragraph 2-12)  
and given a shakeout (reference paragraph

---

**WARNING**

Failure to detect areas of damage may result in malfunction of the parachute and injury or loss of life to personnel.

## 2-16. Packing the 22-Foot Cargo Extraction Parachute (cont).

a. *Inspection.* If defects or damages are discovered during inspection of a parachute, the parachute must be rigger-rolled and processed for maintenance in accordance with TM 10-1670-201-23 and DA PAM 738-751. A rigger type inspection and a pack-in-process inspection must be performed in conjunction with each packing of a parachute (refer to para. 2-13).

(1) *Rigger-type inspection.* Before each parachute is packed for airdrop, it must be given a rigger-type inspection by the packer in accordance with para. 2-13 above.

(2) *Pack-in-process inspection.* A pack-in-process inspection must be performed by a designated supervisory rigger, other than the packer, at seven intervals during the packing procedure. The inspection is performed to assure that the parachute is packed according to authorized packing procedures. (Refer to para. 2-13).

b. *Orientation.* Throughout this manual, all directions (right, left, upper, lower, top, bottom, clockwise, and counterclockwise) are given from the rigger's point of view, as the rigger stands at the tension plate end of the packing table facing the apex-hook end of the table (figure 2-9).

(1) Top, that portion of the equipment that is farthest from the packing table surface.

(2) Bottom, that portion of the equipment that is nearest to the packing table surface.

c. *Preparing Parachute for Proper Layout.* Prepare the parachute as follows:

(1) If components of the parachute assembly are detached, assemble the parachute during layout in accordance with paragraph 2-8. Place packing tools in convenient locations on the packing table. Lay the canopy assembly lengthwise on the packing table, and attach the canopy to the packing table apex hook (figure 2-10).

(2) Attach the connector links to the tension plate and apply enough tension to keep the canopy on the table. Check vent lines to determine if the canopy is inverted. If the vent lines do not appear attached to the outside of the upper lateral band, the canopy is inverted.

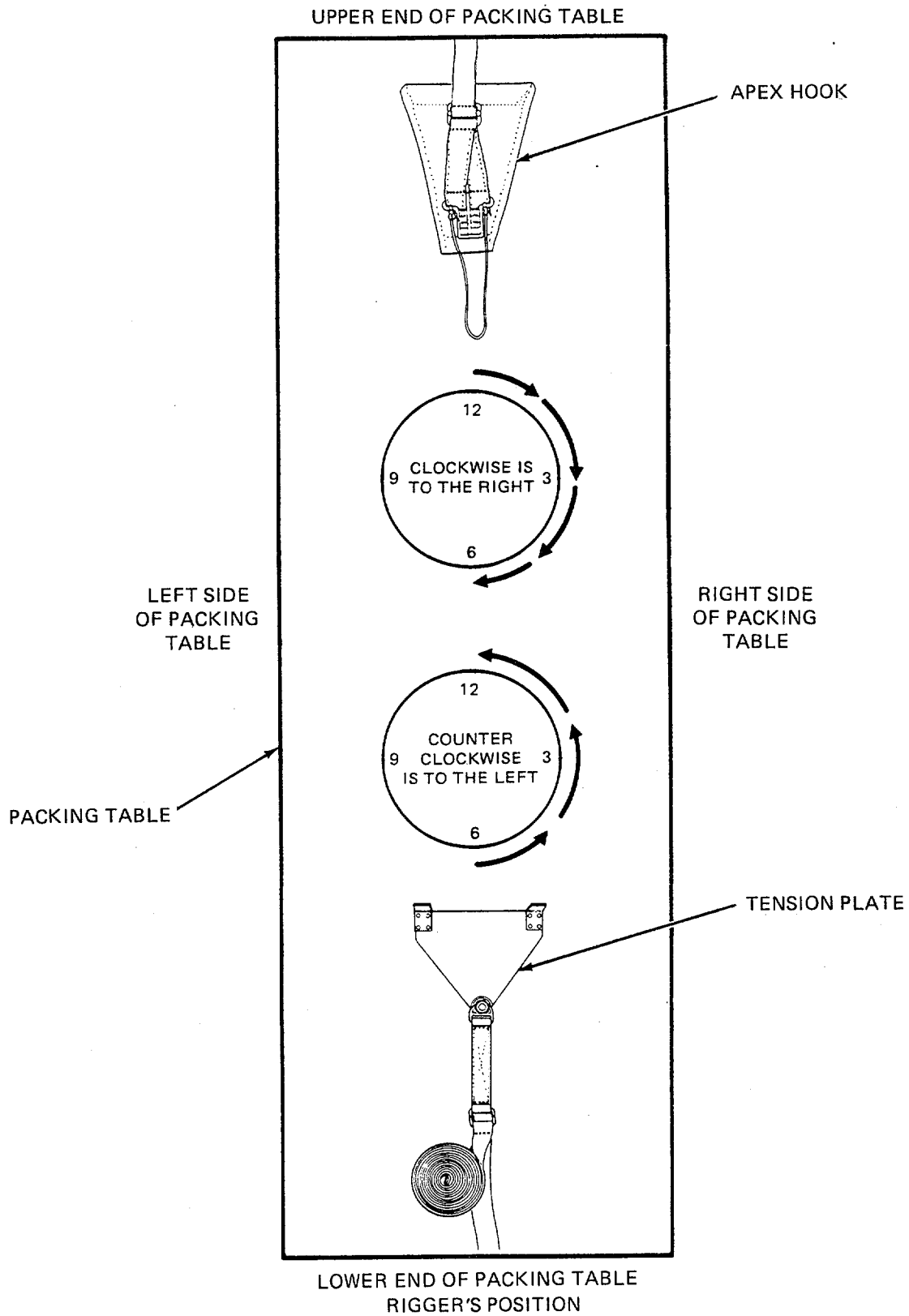
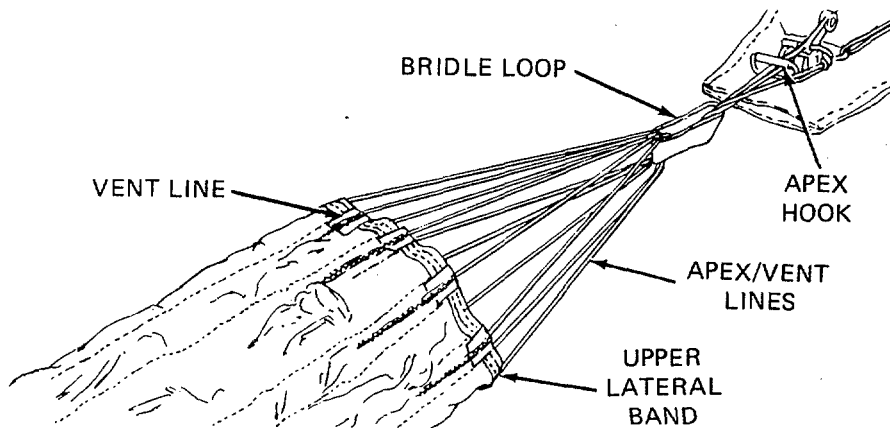

Figure 2-9. Rigger's Orientation.  
2-27

2-16. Packing the 22-Foot Cargo Extraction Parachute (cont).



4728-014

**Figure 2-10. Canopy Attached to Packing Table Apex Hook.**

**NOTE**

After placing parachute in proper layout, ensure a type V coreless nylon suspension line spacer is between lines 7 and 8, and lines 21 and 22. When inversion, turns, tangles and twist are present in the canopy assembly, the proper sequence for removal to achieve proper layout is to remove an inversion first, remove turns secondly, then remove tangles, and finally, remove twist.

d. **Removing Inversion.** The canopy vent lines shall be checked to ascertain if the canopy has been inverted. Should the vent lines be on the inside of the upper lateral band, the canopy is inverted. To remove an inversion, proceed as follows:

- (1) Remove the canopy from apex hook, pass canopy vent down through the canopy.
- (2) Bring vent out at skirt between two adjacent suspension lines (figure 2-11).
- (3) Reattach the canopy to apex hook after the inversion is removed.





Figure 2-11. Removing Inversion.

e. *Removing Partial Inversion.* A partial inversion may occur in an extraction parachute with a ringslot-type canopy. If the vent is on the outside of the canopy and the pocket bands are on the Inside, or vice versa, a partial inversion exists. Remove the partial inversion.

- (1) Disconnect bridle loop from apex hook.
- (2) Trace radial and vertical tapes to annular ring or ringslot, where tapes turn under to canopy and out through annular ring applicable ringslot (figure 2-12).
- (3) Reattach bridle loop to apex hook.

2-16. Packing the 22-Foot Cargo Extraction Parachute (cont).



Figure 2-12. Removing Partial Inversion.

4728-016

f. Locating Suspension Lines. To properly locate suspension lines, proceed as follows:

**NOTE**

Suspension lines 1 thru 28 are divided into two groups, lines 1 thru 14 in left group and lines 15 thru 28 in right group.

- (1) Divide the suspension lines into left and right groups.
- (2) Place a packing weight around the right group of lines and move weight toward risers, checking for turns, tangles and twists.
- (3) When inversion, turns, tangles, and twists are present in a canopy assembly, the proper sequence for removal to achieve proper layout is to remove an inversion first, remove turns secondly, then remove tangles, and finally, remove twists as follows:

(a) *Turns*. A turn occurs when one group of suspension lines rotates around other group (figure 2-13).

- 1 Remove connector links from tension plate and remove a turn by rotating adapter web in direction opposite to direction of turn.
- 2 Reposition connector links on tension plate.

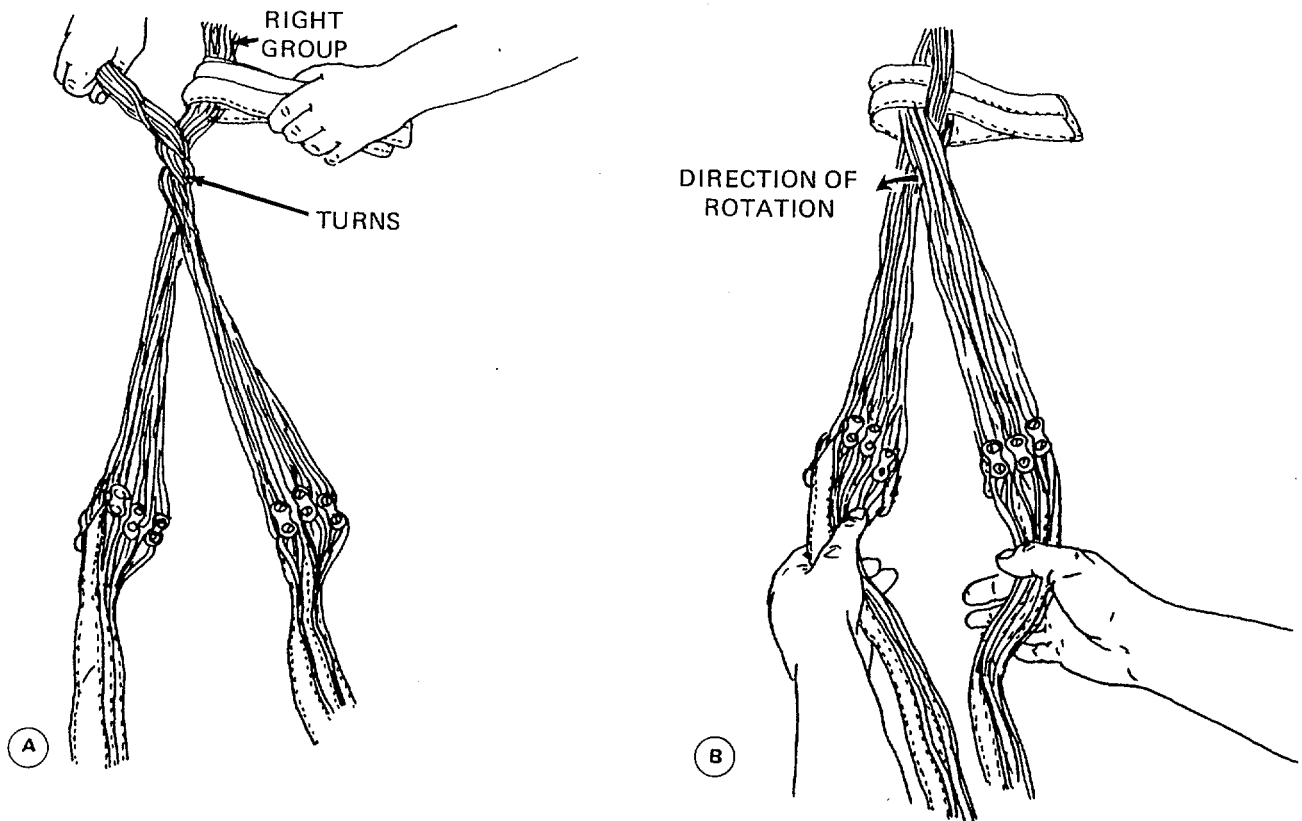

4728-017

Figure 2-13. Removing Turns from Suspension Lines.

(b) *Tangles.* To remove a tangle, or tangles, keep the two groups of lines separated and work the tangle, or tangles, as close to the connector links as possible. Detach connector links from the tension plate (figure 2-14).

- 1 Select top line, or lines that form the tangle and, with left hand, lift line, or lines, away from other lines (figure 2-14).
- 2 Reach through opening, created by lifting the suspension lines, with right hand (B, figure 2-14) and pull adapter web through opening.
- 3 Replace connector links on tension plate.

2-16. Packing the 22-Foot Cargo Extraction Parachute (cont).

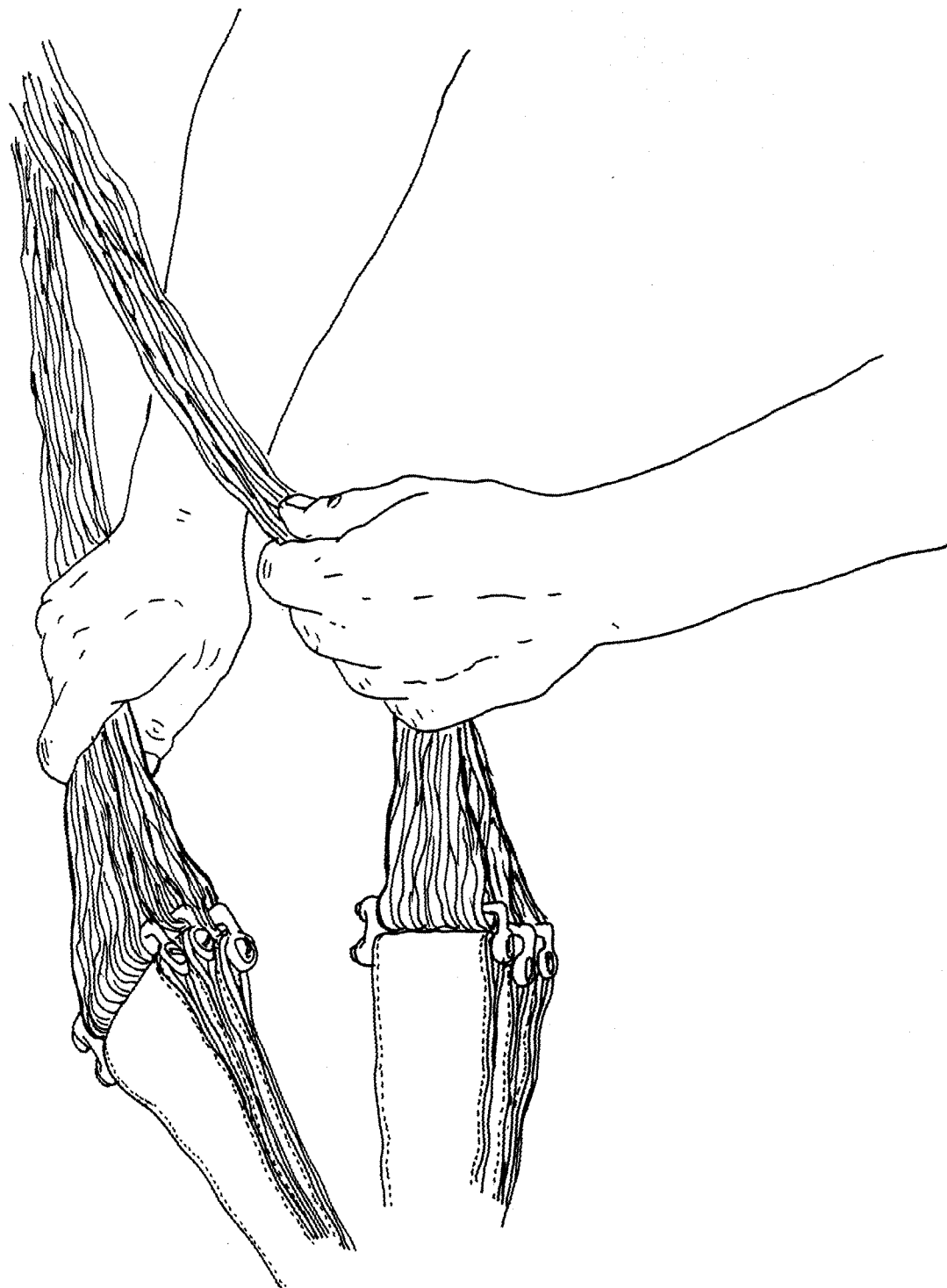

Figure 2-14. Removing Tangles from Suspension Lines.

(c) *Twists*. A twist occurs when the suspension lines within one group becomes improperly crossed (figure 2-15).

- 1 To remove twists, grasp inside lines at skirt of canopy and trace them to connector links (figure 2-15)

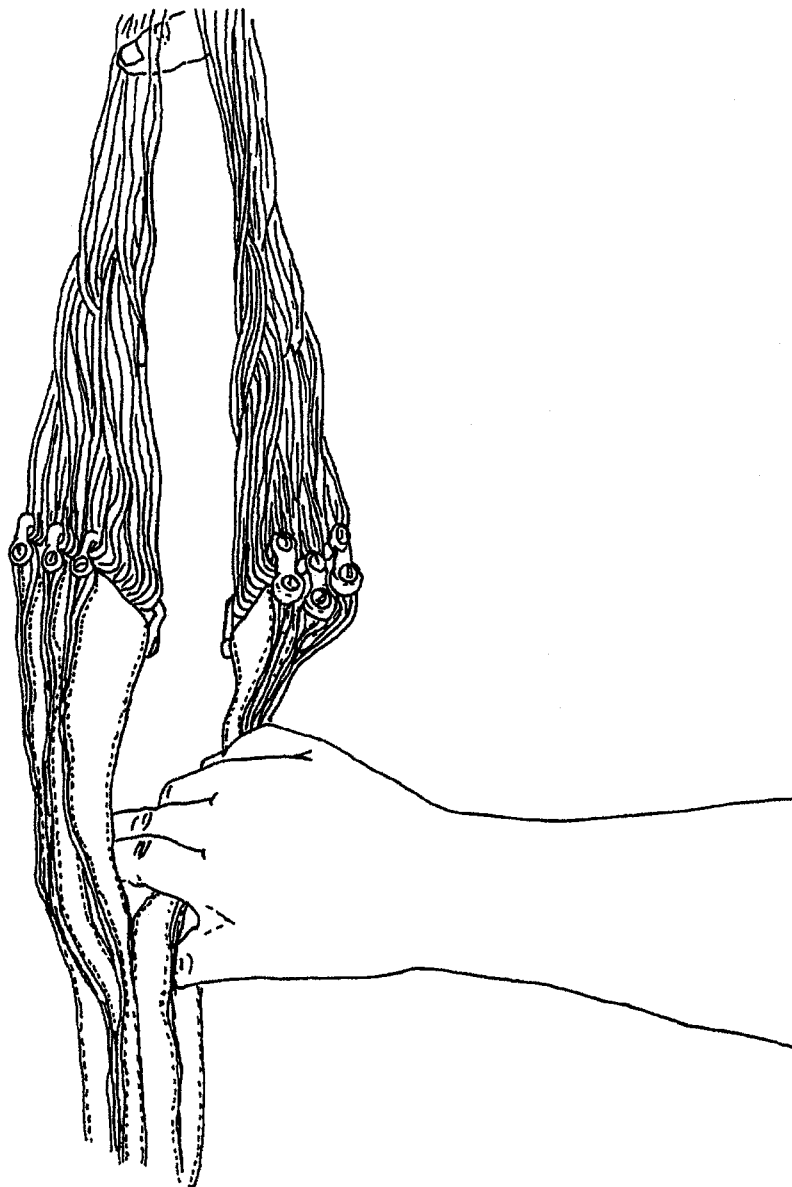

Figure 2-15. Removing Twists from Suspension Lines.

## 2-16. Packing 22-Foot Cargo Extraction Parachute (cont.)

2 Remove twist by rotating adapter web until lines are in proper location on connector links.

(4) Check suspension lines for proper layout (figure 2-16). Lines 1 and 28 WILL BE inside of top connector links. Lines 14 and 15 WILL BE be outside bottom of connector links.

(5) Parachute is now in proper layout.

### NOTE

Before proceeding to pack the parachute (NSN 1670-00-687-5458), The type X extraction line should be inspected for damage. If the extraction line is damaged, the type X adapter web will be removed and a type XXVI adapter web will be installed. When this is accomplished, the NSN for the 22-foot-diameter cargo extraction parachute will be changed to 1670-01-063-3716.

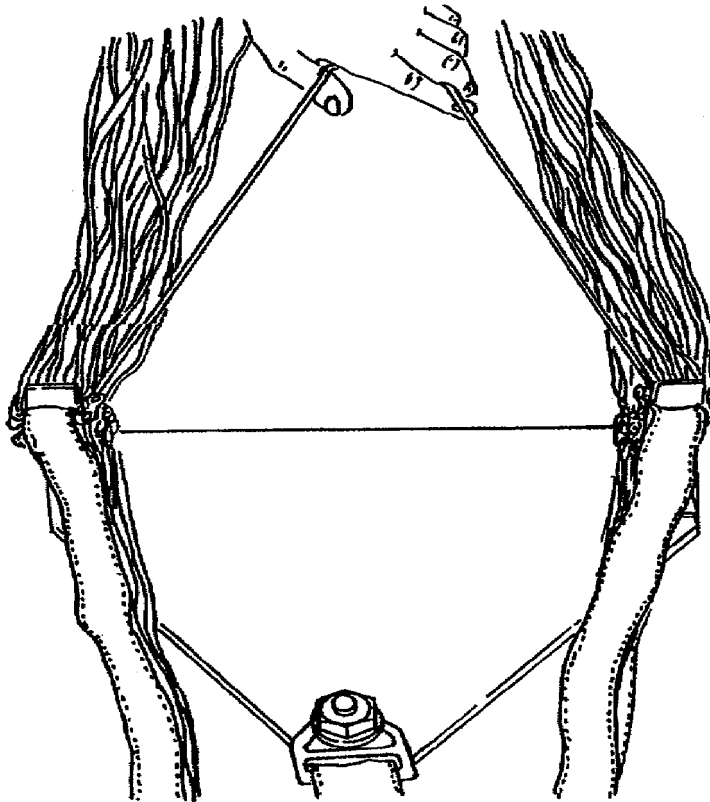
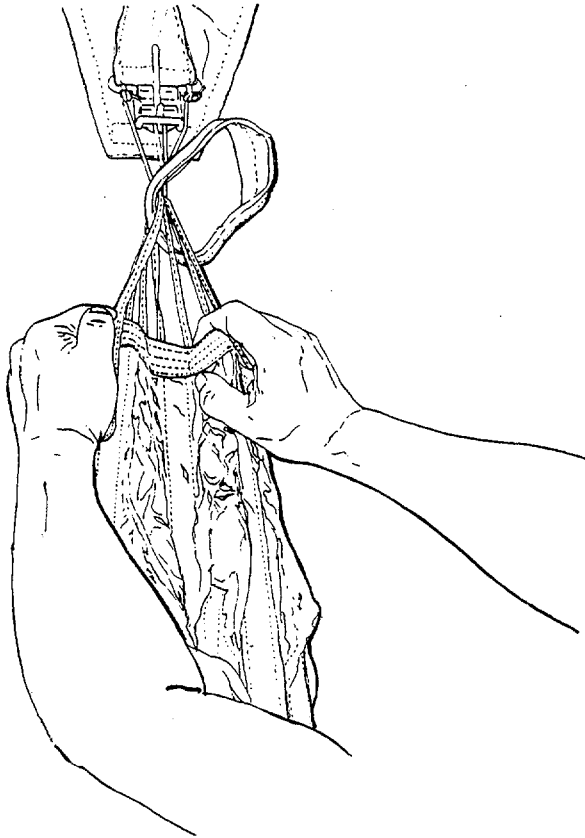

Figure 2-16. Line 1 and 28/14 and 15 Checked at Connector Link.

g.. Attaching and Stowing Deployment Bag Retaining Tie. Attach and stow retaining tie following the procedures in paragraph 2-8.

*h. Folding the Gores.* Fold canopy gores as follows:

- (1) Dress apex, apply tension to canopy (figure 2-17).



4728-021

*Figure 2-17. Dressing the Apex.*

**2-16. Packing the 22-Foot Cargo Extraction Parachute (cont).**

- (2) Pick up right group of suspension lines with left hand. Using right hand to hold top center gore in position, flip right group of gores over left group of gores (figure 2-18).



4728-022

*Figure 2-18. Flipping Right Group of Gores.*



- (3) Using left hand, pick up line 15 at canopy skirt and place line between thumb and forefinger of right hand. Move line to right edge of table, and fold right group of gores (A, figure 2-19).

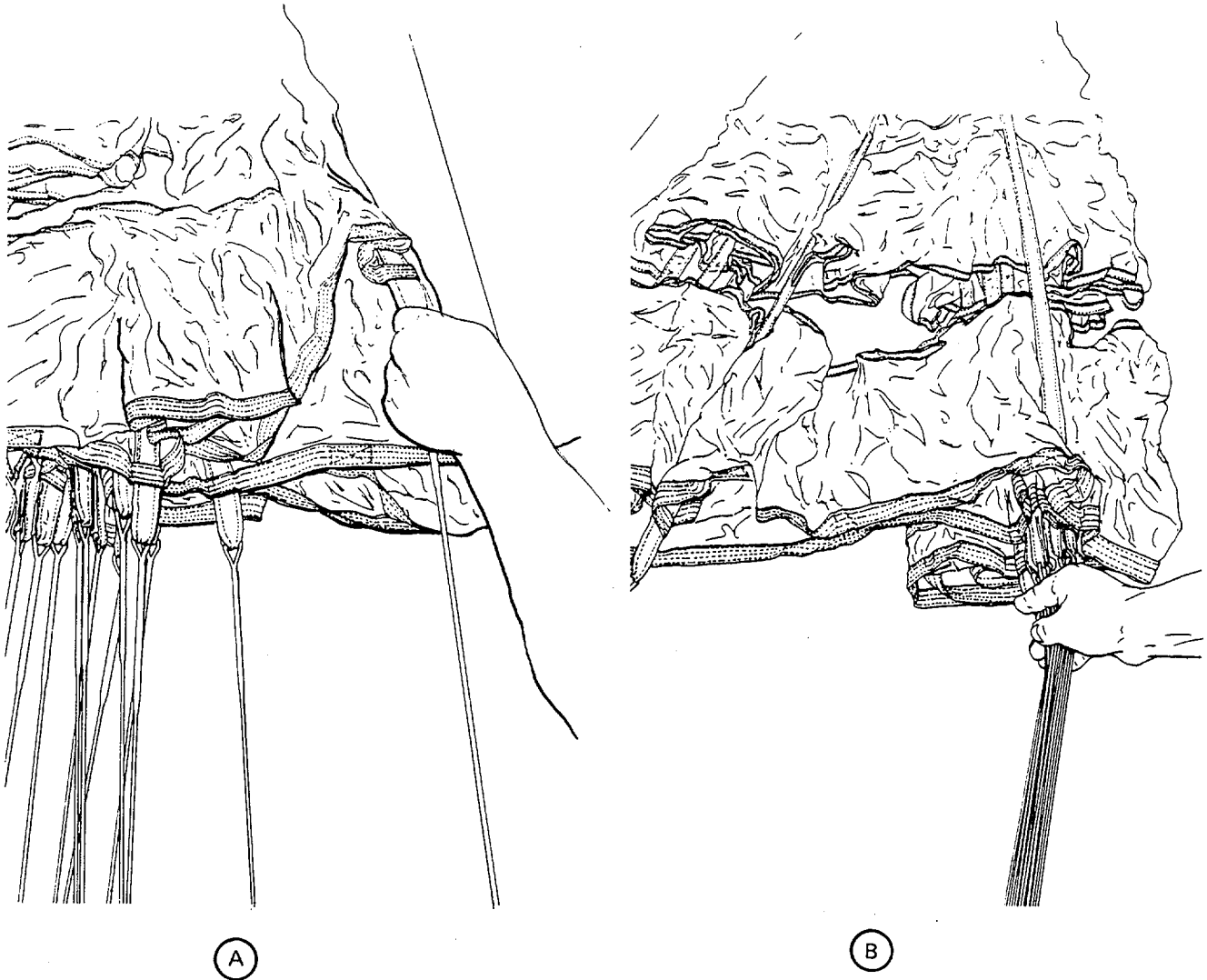

4728-023

Figure 2-19. Folding Right Gore Group.

- (4) Using the right hand, scissor right group of suspension lines between middle and forefingers. Rotate right hand one-quarter turn clockwise (B, figure 2-19).
- (5) Beginning with line 1, fold left group of gores, do not fold last two gores in this group.

**2-16. Packing the 22-Foot Cargo Extraction Parachute (cont).**

- (6) Raise last suspension line of left gore group and drape last gore on left. The next to last gore shall be draped on right. After draping last two gores, place last suspension line on top of other lines in last group (figure 2-20).
- (7) Place two suspension line groups into a line separator at a point just below canopy skirt.

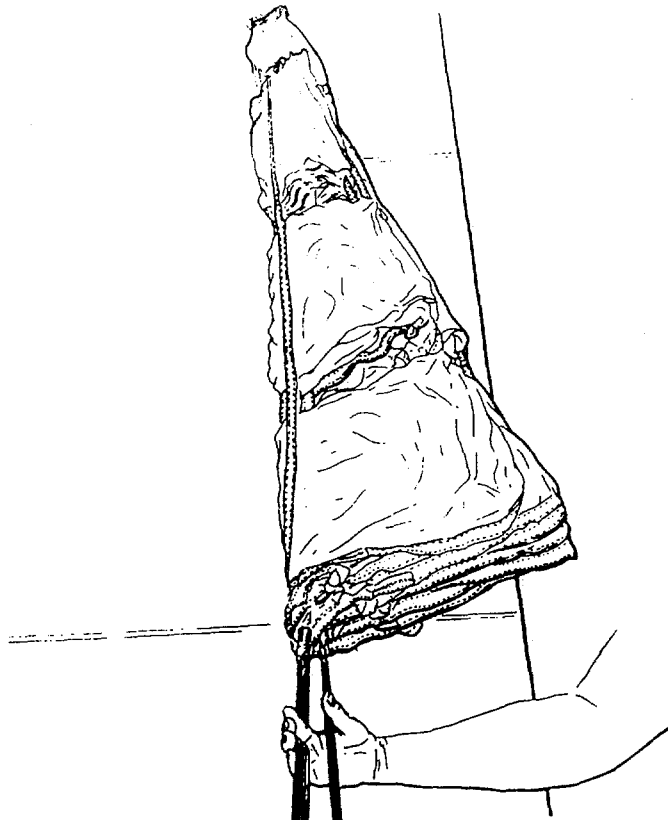

4727-089

*Figure 2-20. Left Gore Group Fold Complete.*

- (8) Using left hand, hold line separator and separated lines. Grasp canopy with right hand and pull canopy off right side of pack table, allowing all folded gores to drape downward to side of table (figure 2-21).
- (9) Slide canopy back onto table and rotate suspension lines and line separator one-half turn counterclockwise which will allow the separator base to rest on the table.
- (10) Flip left group of gores to left side of table top and apply additional tension (figure 2-22).

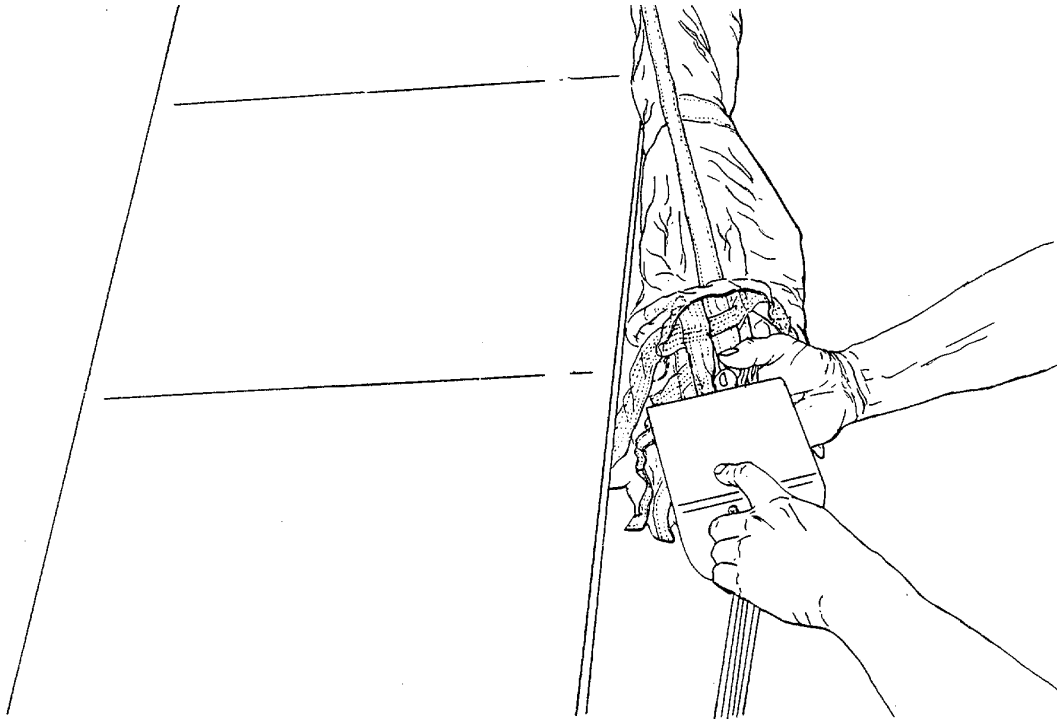

4728-025

Figure 2-21. Draping Folded Gores.

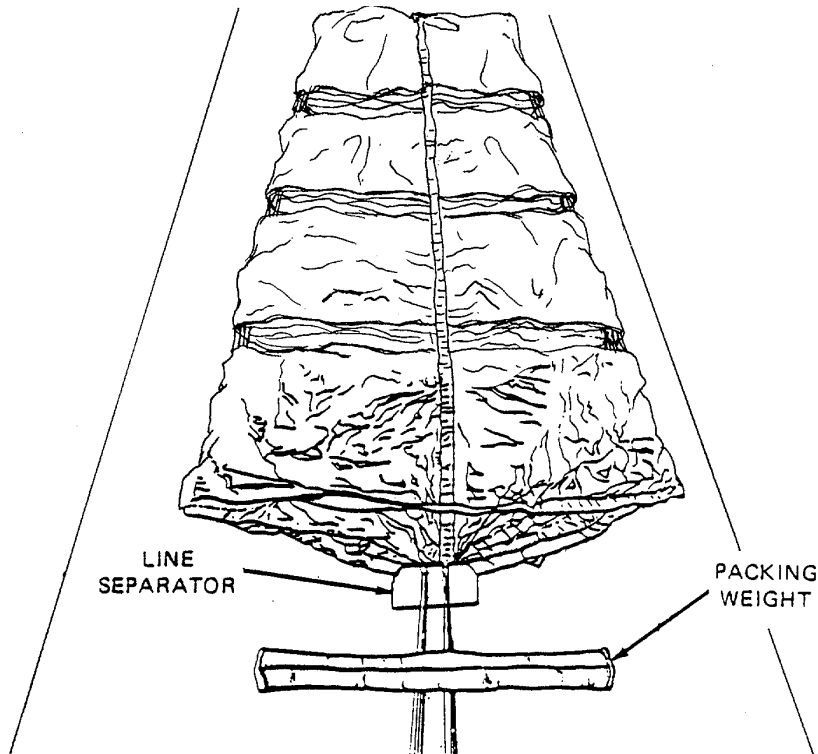

4728-026

Figure 2-22. Flat Fold Complete.

**2-16. Packing the 22-Foot Cargo Extraction Parachute (cont).**

(11) To complete the canopy flatfold, dress the gores and the skirt reinforcement (lower lateral band). Ensure that 14 gores are in each-gore group and that a clear air channel exists between the two gore groups. Lay a packing weight across the suspension lines just below the line separator (figure 2-22).

i. Long Folding the Canopy. Beginning with panel/section number 1, fold first four sections of right group of gores from the center of each section over radial seam. Repeat same procedure for left group of gores. Place packing weights on folded panel/sections to hold the folds in position. Ensure longfold does not exceed width of deployment bag (figure 2-23).

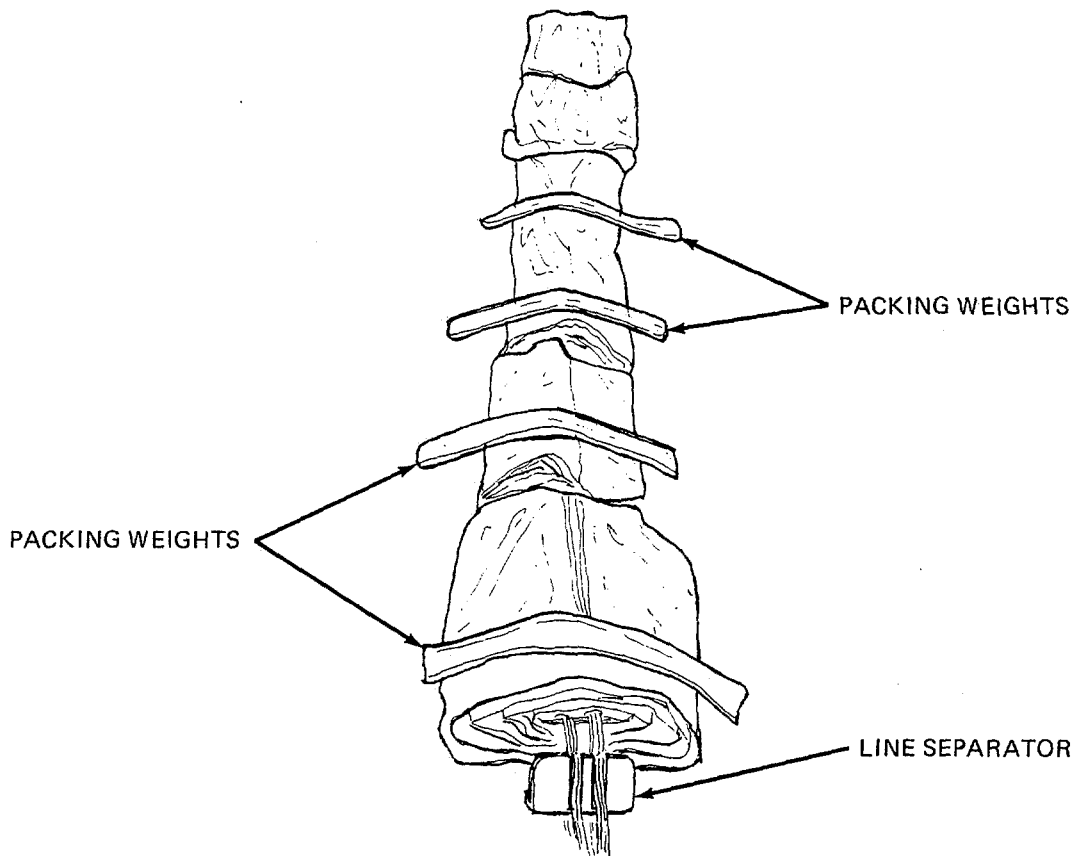

4728-027

Figure 2-23. Long Fold Complete.

i. 1 Attaching Deployment Bag.

a. Bag Retaining Line.

- (1) Pull deployment bag retaining line loop from bag inside and insert canopy bridle loop into retaining line loop (A, figure 2-24).
- (2) Holding bag retaining line loop and canopy bridle loop in place, pull deployment bag through bridle loop and draw retaining line taut to secure bag retaining line to bridle loop (B, figure 2-24).
- (3) S-fold excess bag retaining line length to form 4-inch folds. Secure folds with a rubber retaining band (C, figure 2-24).

b. Bag Retaining Line Alternate. If the deployment bag is not attached to the vent loop (bridle loop), attach the bag retaining line as follows:

- (1) Cut a 72 inch length of 1 inch wide tubular nylon webbing for use as a bag retaining line.
- (2) Pass one end of the bag retaining line through the canopy vent loop (bridle loop) and center the line length in the loop.
- (3) Aline the webbing ends and pass the alined ends into the bag and out of the bag end slot.
- (4) Position the end of the canopy vent loop (bridle loop) at the open end of the deployment bag.
- (5) At the bag top, pass one running end of the retaining line over the top of the deployment bag bridle straps and pass the opposite running end under the bridle straps.
- (6) Secure the webbing ends together above the bag bridle straps with a surgeons knot and a locking knot. Make an overhand knot in each running end and trim ends to 2 inches. The bag retaining line finished length shall measure approximately the same length as the deployment bag.

j. Stowing the Canopy.

- (1) Before stowing the canopy, install rubber retainer bands at equal intervals along the suspension line stowage flap stow loops. Release canopy from apex hook.

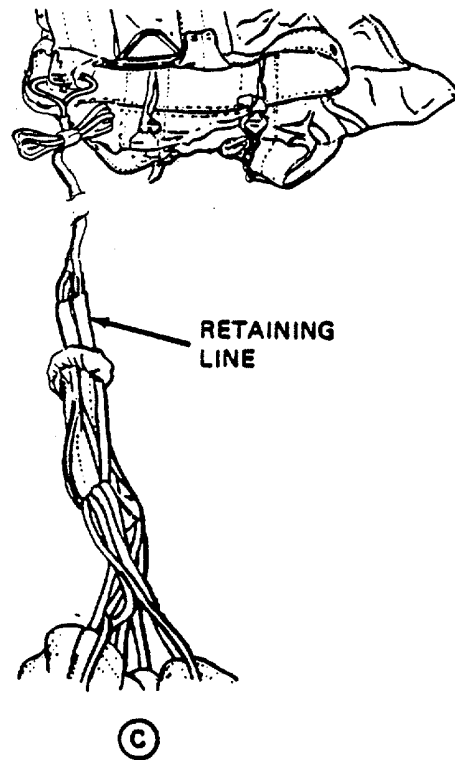
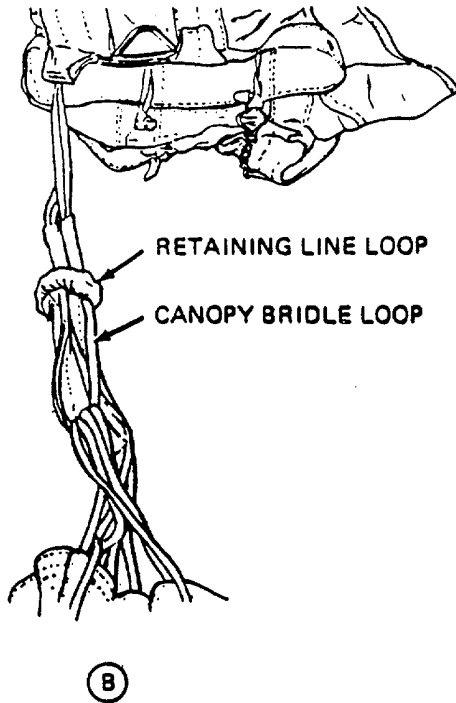
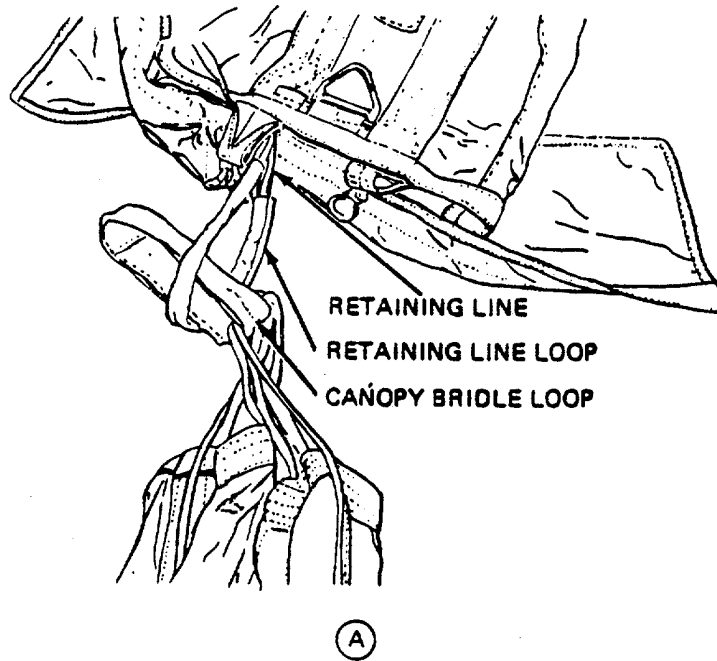

Figure 2-24. Attaching Bridle Loop to Deployment Bag.

- (2) Beginning at upper right inside corner of deployment bag, stow canopy in the bag with S-fold (A, figure 2-25). Upon completion of canopy stowage, suspension lines should extend from left side of the bag open end (B, figure 2-25).
- (3) Stand deployment bag upright with suspension lines routed from left side of deployment bag.
- (4) Using one turn single, thread, cotton no. 8/7 route thread through top and bottom center bag tie loops by passing thread ends through tie loop from right to left. Fold suspension lines from left to right over skirt of canopy and routed thread. Secure tie over the folded suspension lines with a surgeon's knot and a locking knot. Trim tie ends to 2 inches (B, figure 2-25).

## 2-16. Packing the 22-Foot Cargo Extraction Parachute (cont).

### k. Stowing the Suspension Lines.

#### NOTE

When making suspension line stows ensure stows do not exceed the width of the deployment bag.

- (1) Right of secured center bag tie loops, form a loop in suspension lines and make first suspension line stow at upper right corner of deployment bag suspension line stowage flap. Secure stow with the previously installed retainer band (A, figure 2-26).
- (2) Extend suspension lines to upper left corner of stowage flap, form a loop in the suspension line and secure stow with previously installed retainer band.
- (3) Using procedures in (1) and (2) above, continue stowing suspension lines on stowage flap to a point within six inches of suspension line connector link assemblies. Make last stow at the lower right side of the stowage flap (B, figure 2-26).

### l. Closing the Deployment Bag.

- (1) Position suspension line connector link assemblies back on top of stowed suspension lines and extend adapter web across stowed suspension lines to upper left corner of deployment bag (A, figure 2-27). S-fold the adapter web across the stowed suspension lines. Insure the adapter web extends 9 to 12 inches from the left side of the deployment bag.
- (2) Fold right side of suspension line stowage flap over stowed suspension lines, fold left flap over right flap (B, figure 2-27).
- (3) Beginning at lower end of suspension line stowage flap, tightly roll flap into open end of deployment bag. Ensure adapter web extends from left side of deployment bag (figure 2-28).







(A) S-FOLDING CANOPY

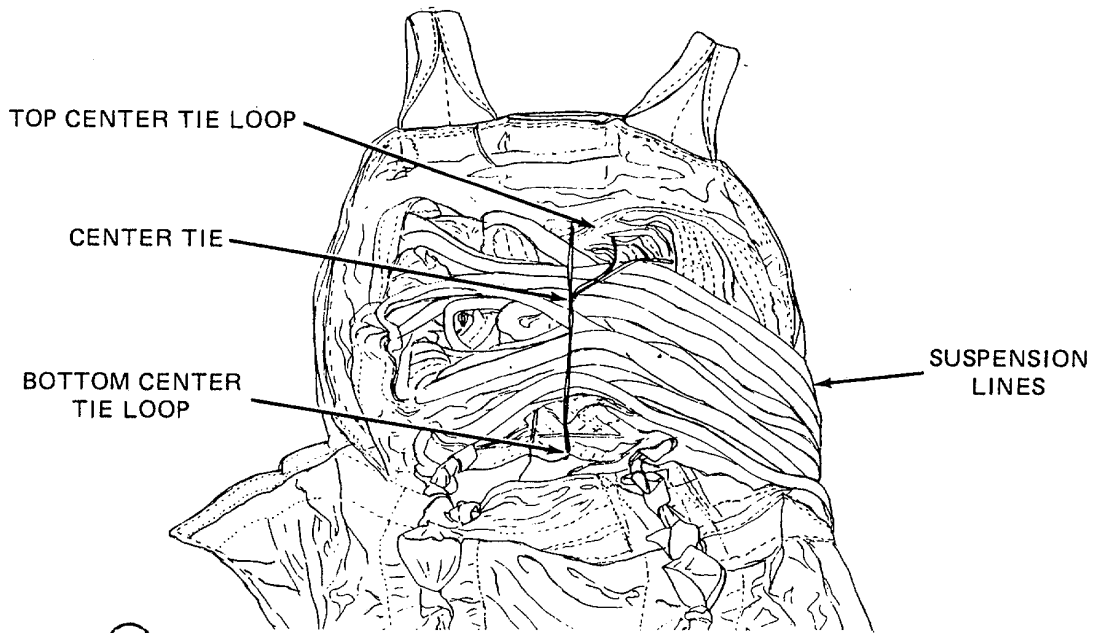

(B) CANOPY STOW COMPLETE

4728-029

Figure 2-25. Stowing Canopy.

2-16. Packing the 22-Foot Cargo Extraction Parachute (cont).



(A) FIRST STOW

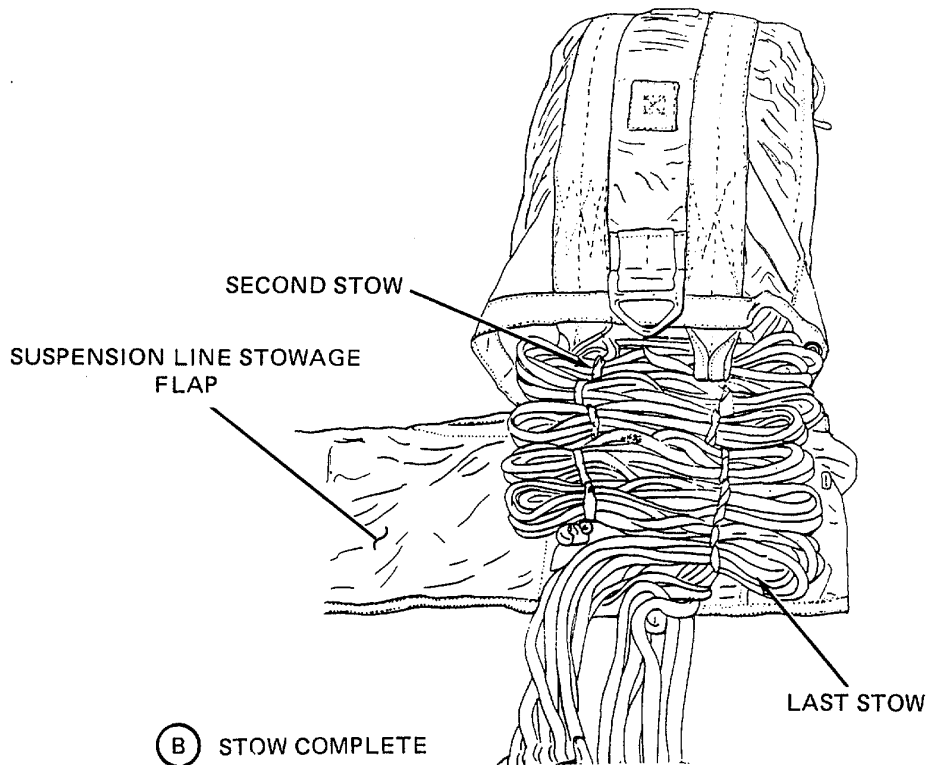

4728-030

Figure 2-26. Stowing Suspension Lines.

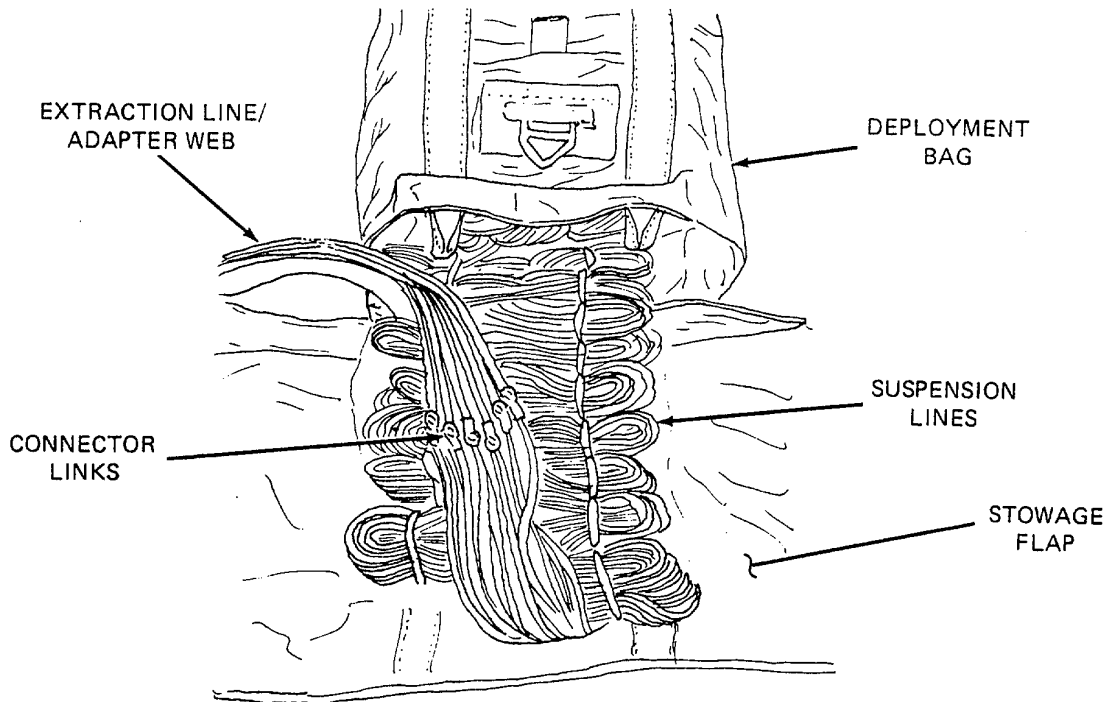

(A) THE CONNECTOR LINK ASSEMBLIES AND EXTRACTION LINE/ADAPTER WEB POSITIONED.

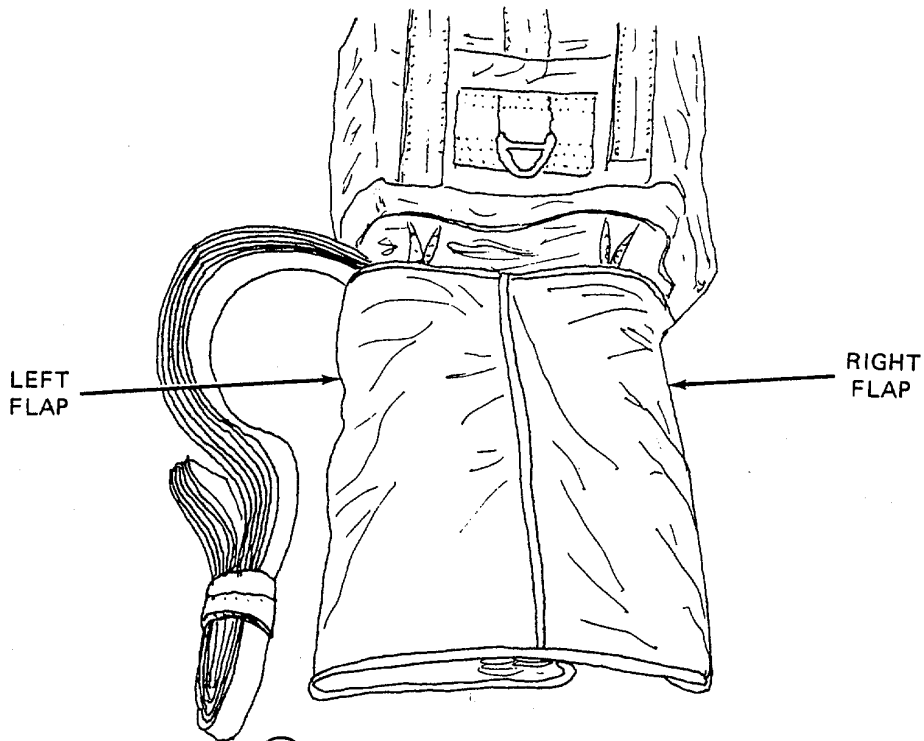

(B) SUSPENSION LINE STORAGE FLAP CLOSED.

4728-031

Figure 2-27. Suspension Line Connector Link Assemblies in Position with Adapter Web.

2-16. Packing the 22-Foot Cargo Extraction Parachute (cont).

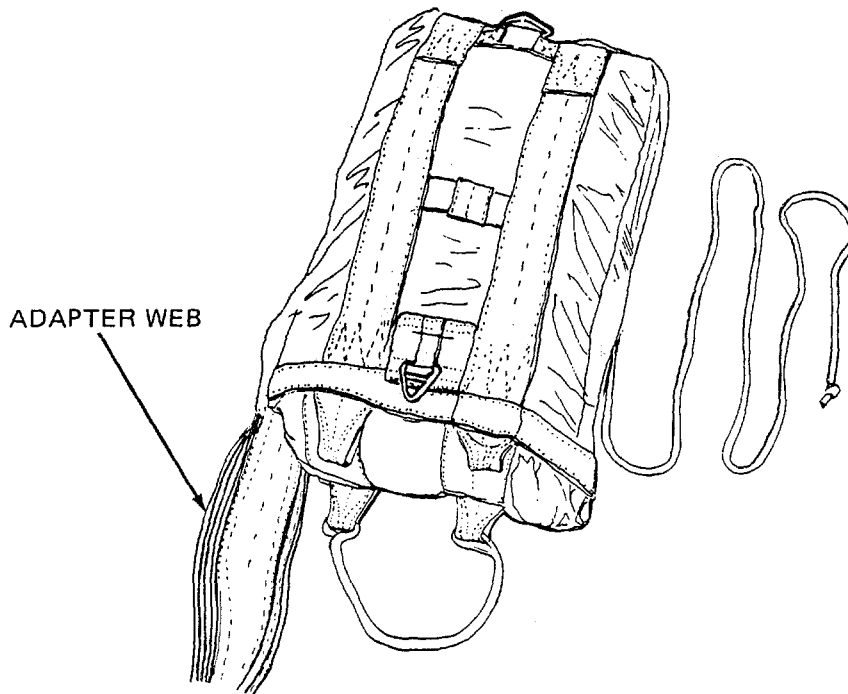

4728-032

Figure 2-28. Suspension Line Stowage Flap Rolled into Open End of Deployment Bag.

- (4) Fold extended adapter web from left to right across rolled suspension line stowage flap (figure 2-29).
- (5) Using a single length of 1/4-inch cotton webbing, make left bag closing tie by passing one end of thread through left bottom bag closing loop from right to left, up behind adapter web, through top bag closing loop from left to right, secure ends together over adapter web, with a surgeon's knot and a locking knot. Trim tie ends to 2-inches (figure 2-29).
- (6) Using a single length of 1/4-inch cotton webbing, make right bag closing tie by passing one end of thread through right bottom bag closing loop from left to right, up behind extraction line or adapter web, as applicable, up through right side bag grommet, through right bag closing loop from right to left, secure ends together over adapter web, with a surgeon's knot and a locking knot (figure 2-29).

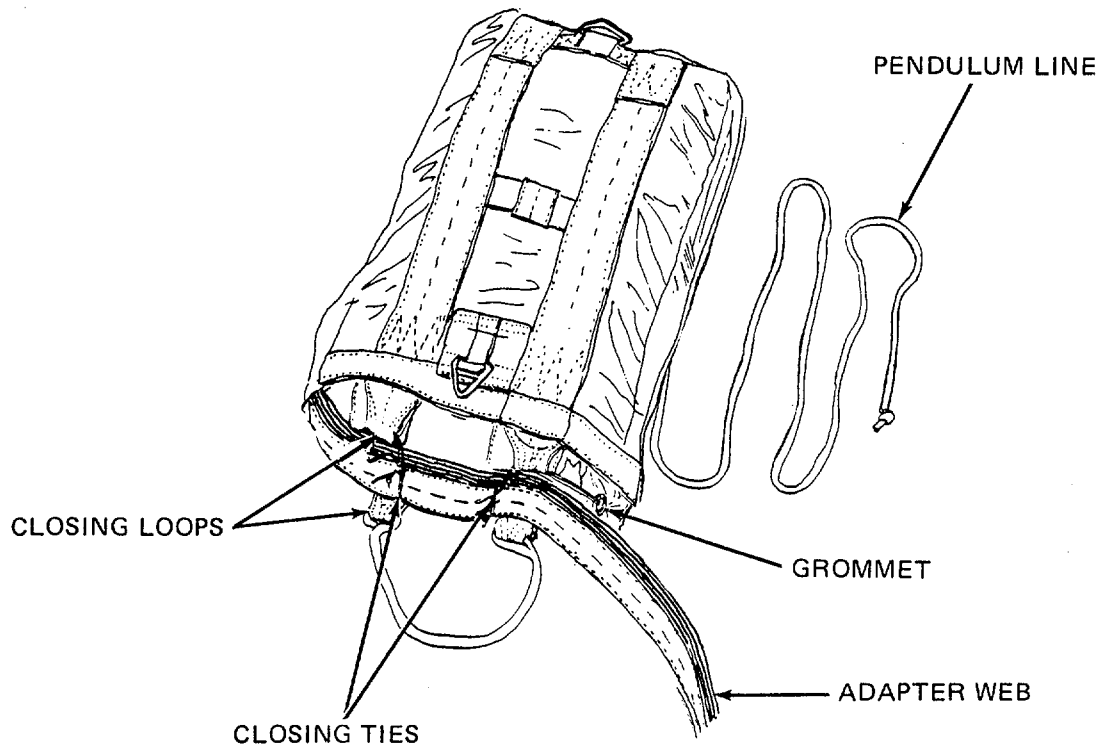

4728-033

*Figure 2-29. Left and Right Deployment Bag Closing Ties.*

- (7) Pull bag opening safety cord up over bent V-ring. Secure safety loop by passing the pendulum line running end through the V of V-ring, draw the pendulum line tight, make additional loops between V-rings as required and secure pendulum line with a half-hitch (figure 2-30).

2-16. Packing the 22-Foot Cargo Extraction Parachute (cont).

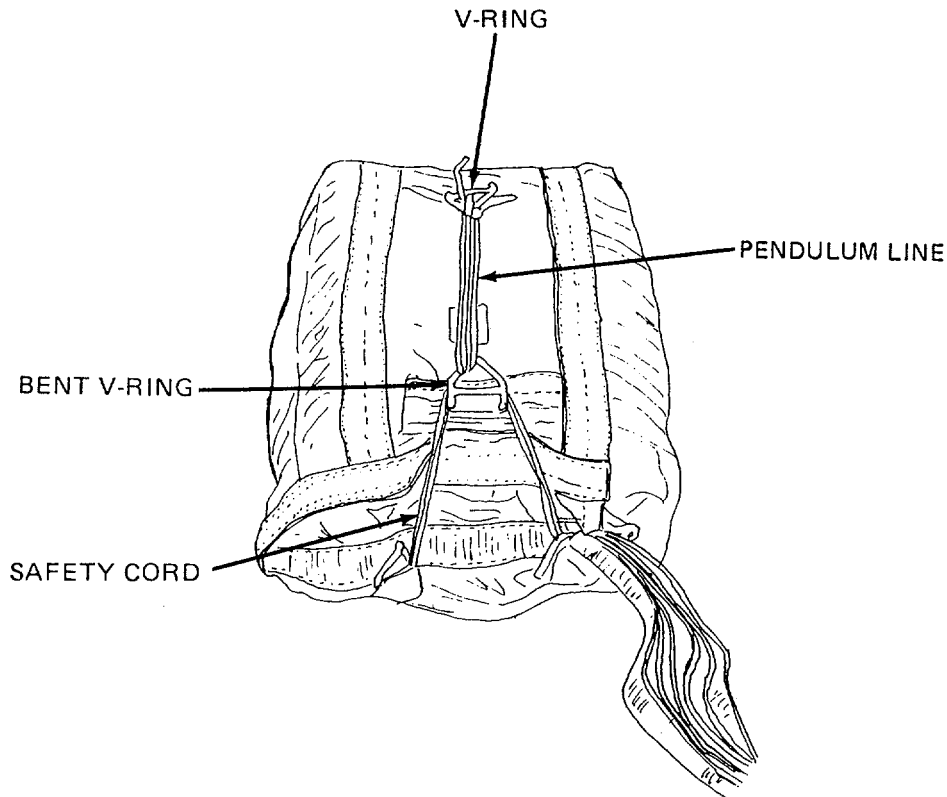

4728-034

Figure 2-30. Bag Opening Safety Loop and Pendulum Line Secured.

m. Attaching the Extraction Line. Extraction Parachute NSN 1670-00-687-5458 requires a 60-foot, three-loop, Type X Extraction line and may only be used on C-130 aircraft. Extraction Parachute NSN 1670-01-063-3716 will require a 60-foot, three-loop Type XXVI extraction line for C-130 aircraft or a 140 foot, three loop, Type XXVI extraction line for C-141 aircraft. The type X extraction line will not be used on this parachute. Refer to FM 10-500 and TM 10-1670-286-20&P for attachment and stowing of extraction lines.

n. Stowing the Extraction Line, Adapter Web, or Release Line.

- (1) Position packed deployment bag on a packing table with bottom facing up.
- (2) If applicable, secure V-knife, located in extraction line 30 feet from load attaching loop to extraction line webbing using pressure-sensitive tape.
- (3) Stow extraction, adapter web, or release line length as applicable by S-folding along length of deployment bag, making layers of folds, as required. Using deployment bag tiedown loops, secure each layer of S-folded extraction line at a minimum of two points. Make each tie with a suitable length of one turn single, 1/4-inch wide, Type I Cotton webbing (figure 2-31).

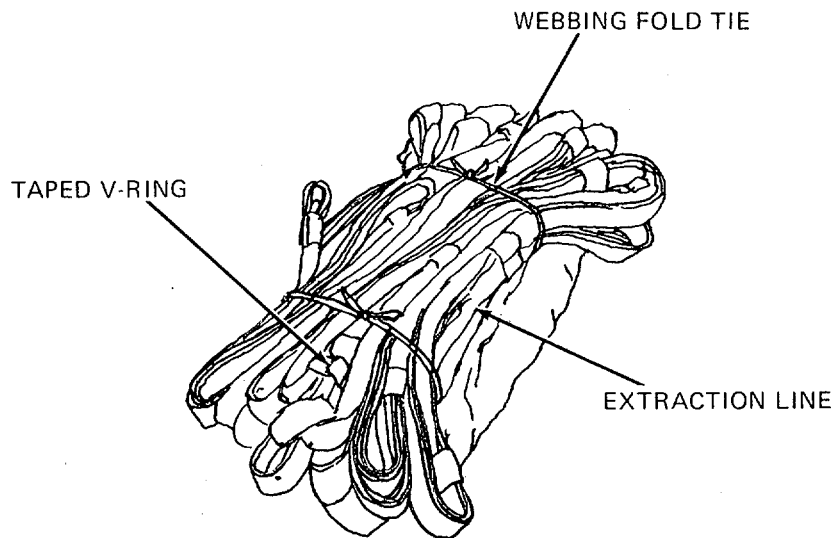

4728-036

Figure 2-31. Stowing the Extraction Line.

o. Signing DA Form 10-42.

- (1) Remove parachute log record book from parachute inspection data pocket (log record pocket) on upper end of the deployment and record pack data as prescribed in para. 2-4.
- (2) After completion of entries, return log record book to inspection data pocket.

**Section VI. REPAIR**

Paragraph		Page
2-17	Maintenance Limitations.....	2-50
2-18	Repair - Sewing Procedures.....	2-51
2-19	Searing and Waxing.....	2-56
2-20	Marking and Restenciling.....	2-57
2-21	Parachute Canopy.....	2-58
2-22	Attachment Loop (Bridal Loop).....	2-59
2-23	Vent Lines.....	2-61
2-24	Bridle Centering Line.....	2-63
2-25	Vent Reinforcement Band (Upper Lateral Band).....	2-65
2-26	Gore Section.....	2-68
2-27	Radial Tape.....	2-74
2-28	Panel Edge Reinforcement.....	2-77
2-29	Skirt Reinforcement (Lower Lateral Band).....	2-79
2-30	Pocket Band.....	2-81
2-31	Suspension Line.....	2-84
2-32	Suspension Line Spacer.....	2-89
2-33	Connector Link.....	2-90
2-34	Deployment Bag.....	2-92
2-35	Grommet.....	2-94
2-36	Deployment Bag Retainer Band Keeper.....	2-99
2-37	Deployment Bag Retainer Tie.....	2-101
2-38	Deployment Bag Closing Loop.....	2-104
2-39	Inspection Data Pocket.....	2-106
2-40	Deployment Bag Retainer Band Keeper Reinforcement.....	2-108
2-41	Deployment Bag Tie Loop and Tie Loop Reinforcement.....	2-110
2-42	Deployment Bag Safety Cord.....	2-112
2-43	Deployment Bag Stowage Flap Edge Binding.....	2-115
2-44	Deployment Bag Stowage Flap Edge Reinforcement.....	2-117
2-45	Deployment Bag Main Strap.....	2-119
2-46	Deployment Bag Panels and Flaps.....	2-120
2-47	Deployment Bag Pendulum Line.....	2-122
2-48	5-Foot Long Adapter Web.....	2-125
2-49	5-Foot Long Adapter Web Body.....	2-126
2-50	5-Foot Long Adapter Web Long Buffer.....	2-127
2-51	Extraction Line (60-Foot Long).....	2-129
2-52	Type IV Quick Release Link Assembly.....	2-130

**NOTE**

Repair and replacement of parachute components is performed in accordance with the general repair instructions in this section, and in specific paragraphs applicable to the item being repaired.

**2-17. Maintenance Limitations.** Only those maintenance functions specified in the Maintenance Allocation Chart (Appendix B) are authorized to be performed on cargo parachutes. Repair cost limitations to preclude uneconomical repair of cargo parachutes shall conform to the requirements of AR 750-1 and TB 43-0002-4.



---

## 2-18. Repair - Sewing Procedures.

---

This task covers:

a. Basting and Temporary Tacking	c. Darning
b. Stitching and Restitching	d. Zig-Zag Sewing

---

*Tools:*

Specified in paragraph applicable to the item being repaired.

*Personnel Required:*

43E(10) Parachute Rigger

*Materials/Parts:*

Specified in paragraph applicable to the item being repaired.

*Equipment Condition:*

Unpacked. Canopy with defects recorded and clean.

---

### NOTE

Sewing requirements will vary according to the type of item being repaired and the type of repair being made. The type of sewing machine, type of thread, the stitch range, and the stitch pattern, if applicable, required to accomplish a sewing procedure will be specified in the paragraph applicable to the item being repaired. All original stitching that is cut during the performance of a sewing procedure will be removed from the applicable item. Immediately after the accomplishment of a machine sewing procedure, trim thread ends to a point as close as possible to the material which has been sewn.

a. *Basting and Temporary Tacking.* Basting and temporary tacking are hand-sewing methods used to temporarily hold layers of cloth fabric together while a repair is being performed. The following is a list of procedures which apply to basting and temporary tacking actions:

- (1) Basting and temporary tacking should be made using thread which is of a contrasting color to the material being worked.
- (2) On small cargo parachute canopies, basting will be made using a single strand of size A, nylon thread identified in individual item repair procedure.
- (3) When basting, do not tie knots at any point in the thread length. Also, the sewing should be made with two stitches per inch.
- (4) Temporary tacking will usually be made using a length of size E nylon thread (item 27/28, Appendix D). However, an alternate type thread may be specified within the paragraph applicable to the item.
- (5) Immediately upon completion of a repair, remove previously made basting or temporary tacking stitches.

**2-18. Repair - Sewing Procedures (cont).**

b. Stitching and Restitching. Perform stitching and restitching as follows, referring to tables 2-2 and 2-3:

(1) *Parachute canopy assemblies.* The stitching and restitching made on parachute canopies should be accomplished with thread that is contrasting in color to the fabric being restitched. If contrasting color thread is not available, thread of matching color may be used, providing all other specifications are met. Straight stitching and restitching on parachute canopy assemblies should be locked by at least 2 inches at each end of a stitch row, when possible. Zig-zag stitching does not require locking; however, zig-zag restitching should extend at least 114 inch into undamaged stitching at each end, when possible. When restitching parachute canopy assemblies, stitch directly over the original stitching and follow the original stitch pattern as closely as possible.

*Table 2-2. Sewing Machine Code Symbols.*

Code symbol	Sewing machine
LD	SEWING MACHINE, INDUSTRIAL: General sewing; 301 stitch; light duty; NSN 3530-01-177-8590.
MD ZZ	SEWING MACHINE, INDUSTRIAL: Zig-zag; 308 stitch; medium duty; NSN 3530-01-181-1421.
LD ZZ	SEWING MACHINE, INDUSTRIAL: Zig-zag; 308 stitch, light duty; NSN 3530-01-181-1420.
HD	SEWING MACHINE, INDUSTRIAL: General sewing; 301 stitch; heavy duty, NSN 3530-01-177-8588.
MD	SEWING MACHINE, INDUSTRIAL: General Sewing; 301 stitch; medium duty, NSN 3530-01-177-8591.
DN	SEWING MACHINE, INDUSTRIAL: Darning; lock stitch; NSN 3530-01-177-8589.
LHD	SEWING MACHINE, INDUSTRIAL: 301 stitch; light heavy duty; NSN 3530-01-186-3079.
ND	SEWING MACHINE, INDUSTRIAL: 301 stitch; double-needle; NSN 3530-01-182-2873.

*Table 2-3. Stitching and Restitching Specifications.*

Component	Recommended sewing machine (code symbol)	Stitches per inch	Thread size
Canopy Gore panel	LD	7-11	E
	DN	Darn	E
Panel edge reinforcement	LD	7-11	E

Table 2-3. *Stitching and Restitching Specifications (cont).*

Component	Recommended sewing machine (code symbol)	Stitches per inch	Thread size
Bridle centering line	ZZ	7-11	E
Suspension line	ZZ	7-11	E
Vent line	ZZ	7-11	E
Attachment loop (bridle loop)	HD	7-11	3
Pocket band	LD	7-11	E
Lateral band (upper and lower)	HD	7-11	3
Radial tape	MD	7-11	E
	LD	7-11	E
Deployment Bag	ZZ	7-11	FF
	MD	5-8	FF
	HD	5-8	3
	ZZ	7-11	FF
Bag closing loop	HD	7-11	FF
	HD	5-8	3
Parachute inspection data pocket	MD	7-11	E
	ZZ	7-11	E
	ZZ	7-11	E
Retainer band keeper- reinforcement	MD	7-11	FF
Tie loop reinforcement	MD	7-11	FF
Safety cord	ZZ	7-11	E
Tie loop	MD	7-11	FF
Edge binding	MD	7-11	FF
Suspension line stowage flap	DN	Darn	E
	MD	5-8	FF
	MD	7-11	FF
Main strap	MD	7-11	FF
Bag panel	DN	Darn	E
Adapter Web (5-foot long)	HD	5-8	5
	HD	5-8	5
	HD	5-8	5

## 2-18. Repair - Sewing Procedures (cont).

(2) *Other parachute items.* Stitching and restitching on other parachute items constructed from cloth, canvas, and webbing should be accomplished with thread which matches the color of the original stitching, when possible. All straight stitching should be locked by backstitching at least 1/2 inch. Restitching should be locked by over stitching each end of the stitch formation by 1/2 inch. Zig-zag stitching does not require locking; however, zig-zag restitching should extend at least 1/4 inch into undamaged stitching at each end, when possible. Restitching should be made directly over the original stitching, following the original stitch pattern as closely as possible:

c. *Darning.* (Refer to tables 2-2 and 2-3). Darning is a sewing procedure used to repair limited size holes, rips, and tears in assorted air delivery items constructed from textile material such as parachute canopy gore sections and the cloth and reinforcement webbing of packs. A darning machine should be used to darn small holes and tears where fabric is missing. Darning of previously patched material can be performed provided darning size limitations prescribed in the paragraph applicable to the item are not exceeded. A darning repair will be performed using the following procedures:

- (1) Using an authorized marking aid of contrasting color, mark a square around the damaged area and ensure that the marking is at least 1/4 inch back from each edge of the damaged area. The marking will be made with the warp and the filling of the material.
- (2) Darn the damaged area by sewing the material in a back-and-forth manner, using size A or E nylon thread, allowing the stitching to run with the warp or filling of the fabric (A, figure 2-32).
- (3) Turn the material and stitch back and forth across the stitching made in (b) above until the hole or tear is completely darned (B, figure 2-32).
- (4) If applicable, restencil informational data, gore number(s), or identification marks using the criteria in para. 2-20.

d. *Zig-Zag Sewing.* (Refer to Tables 2-2 and 2-3). Air delivery items, except parachute canopies, made from textile materials that have sustained cut or tear damage may be repaired by zig-zag sewing provided the applicable damaged area does not have any material missing and the cut or tear is straight or L-shaped. Should the damaged area be irregular shaped or have material missing, the repair will be achieved by either darning or patching, as required. A zig-zag sewing repair will be accomplished with a zig-zag sewing machine, using the following procedures:

- (1) Set the sewing machine to the maximum stitch width.
- (2) Beginning at a point 1/4 inch beyond one end of the cut or tear, stitch lengthwise along the damaged area to a point 1/4 inch beyond the opposite end of the cut or tear (A, figure 2-33). The cited stitching procedure will also apply to an L-shaped cut or tear (B, figure 2-33).
- (3) If applicable, restencil informational data or identification marks as prescribed in para. 2-20.

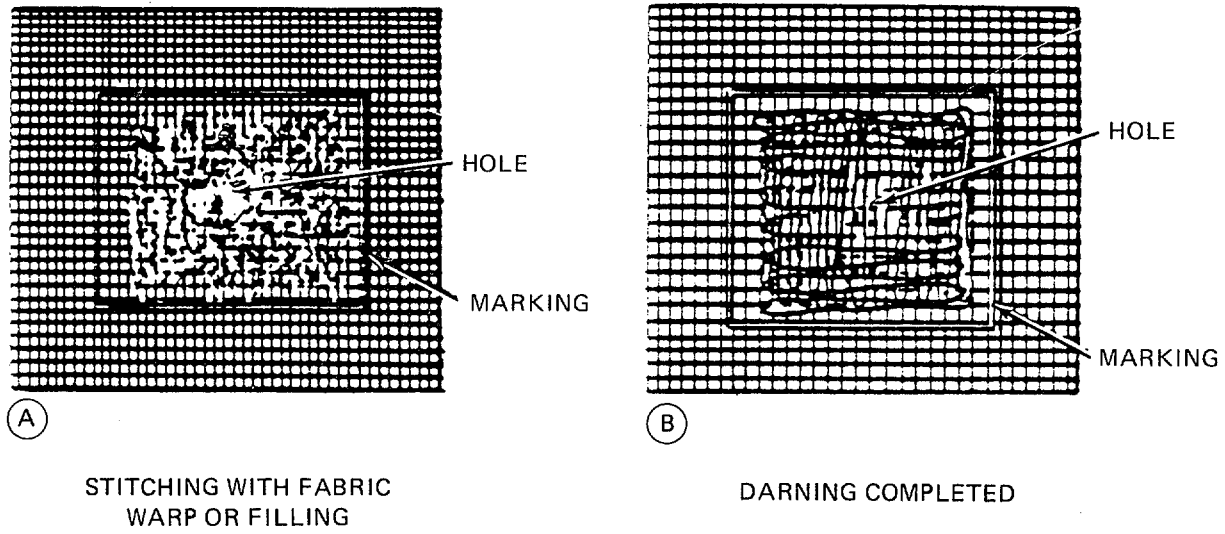

4728-037

Figure 2-32. Darning Method Using a Darning Sewing Machine.

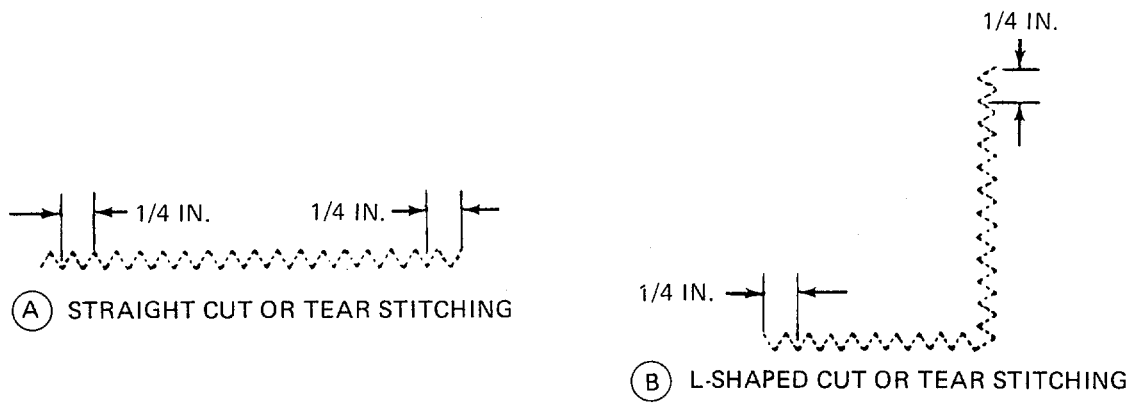

4728-039

Figure 2-33. Repair Method Using a Zig-Zag Sewing Machine.

## 2-19. Searing and Waxing.

---

This task covers:                      a. Searing                      b. Waxing

---

*Tools:*

Pot, Melting, Item 13, Appendix B  
Knife; Hot Metal, Item 5, Appendix B

*Materials/Parts:*

Beeswax, Item 2, Appendix D  
Wax, Paraffin, Item 32, Appendix D

*Personnel Required:*

43E(10) Parachute Rigger

*Equipment Condition:*

Unpacked

---

### **CAUTION**

Cotton tape, webbing, or cord will not be seared.

### **NOTE**

Fabric materials such as cord, tape, and webbing that are cut for use in the maintenance of parachutes will normally be heat-seared or dipped in a melted wax mixture, as applicable, to prevent the material from fraying or unraveling. However, in some instances the preparation of the material may not be necessary and will be specified accordingly.

a. *Searing.* The cut ends of nylon tape, webbing, and cord lengths may be prepared by heat-searing which is performed by pressing the raw end of the material against a hot metal surface (knife) until the nylon has melted sufficiently. Avoid forming a sharp edge or lumped effect on the melted end.

b. *Waxing.* The fraying or unraveling of cotton or nylon tape, webbing, and cord length ends may be prevented by dipping 1/2 inch of the raw end of the material into a thoroughly melted mixture of half beeswax and half paraffin in an electric melting pot. The wax temperature should be substantial enough to ensure the wax completely penetrates the material rather than just coating the exterior fabric.

---

## 2-20. Marking and Restenciling.

---

This task covers:                      a. Marking                      b. Restenciling                      c. Remarking and Restenciling

---

*Tools:*

Brush, Stenciling, Item 2, Appendix B

*Materials/Parts:*

Ink, Marking, Item 9, Appendix D  
Marker, Felt Tip, Black, Item 11, Appendix D  
Pen, Ball Point, Item 14, Appendix D  
Stencilboard, Oiled, Item 19, Appendix D

*Personnel Required:*

43E(10) Parachute Rigger

*Equipment Condition:*

Layout on packing table or other suitable area.

---

### NOTE

Stenciling should be used whenever possible. A ball-point pen or felt tip marker should be used only where stenciling is not possible, or when stenciling devices are not available. However, only felt tip markers that contain parachute marking ink and marked "FOR PARACHUTE MARKING" is authorized for use in marking airdrop items. Any type ball point-pen using black or blue ink may be used for marking on labels only.

Original stenciled data or marking that becomes faded, illegible, obliterated, or are removed as a result of performing a repair procedure will be remarked with a ball-point pen, felt tip marker, or restenciled. All marking or restenciling will be done on or as near as possible to the original location and should conform to the original lettering type and size.

a. Marking. Using marking devices such as ball-point pen or felt tip marker mark on, or as near as possible to, original location and conform to original lettering type and size.

b. Restenciling. Proceed as follows:

- (1) Cut oiled stencilboard to original lettering type and size of data to be restenciled.
- (2) Place cut stencilboard over, or as near as possible to, original marking to be restenciled.
- (3) Place additional sheet of stencilboard beneath the area to be restenciled to prevent the marking ink from penetrating to other areas.
- (4) Hold stencilboard in place and, using stenciling brush filled with parachute marking ink, restencil original marking.

c. Remarking and Restenciling. Remark or restencil original stenciled data or markings that become faded, illegible, obliterated or have been removed as a result of performing a repair procedure. Ensure all marking or restenciling is on, or as near as possible to, the original location and conforms to the original lettering type and size.

**2-21. Parachute Canopy.**

---

This task covers:                      a. Repair                      b. Replace

---

*Personnel Required:*

43E(10) Parachute Rigger

*Reference:*

Group 01, MAC, Section II, Appendix B

*Equipment Condition:*

Cleaned, paragraph 2-12  
Inspected, paragraphs 2-9, 2-13  
Unpacked, canopy laid flat

---

- a. Repair. Refer to individual component/assembly repairs and replacement procedures.
- b. Replace. Replace an unserviceable/unrepairable parachute with a serviceable parachute canopy from stock.



## 2-22. Attachment Loop. (Bridle Loop)

---

This task covers:                    a. Repair                    b. Replace

### *Tools:*

Knife, Item 4, Appendix B  
Pot, Melting, Item 13, Appendix B  
Sewing Machine, Heavy Duty, Item 18,  
Appendix B  
Shears, Item 14, Appendix B  
Yardstick, Item 24, Appendix B  
Unpacked, canopy laid flat

### *Materials/Parts*

Marking Aid, Item 15116, Appendix D  
Thread, Nylon, Size 3, Item 30/31,  
Appendix D  
Webbing, Cotton, Type VIII, Item 34,  
Appendix D

### *Personnel Required:*

43E(10) Parachute Rigger

### *Equipment Condition:*

Cleaned, paragraph 2-12  
Inspected, paragraphs 2-9, 2-13

### *Reference:*

Group No. 01, MAC, Section II,  
Appendix B

---

- a. *Repair.* Repair an attachment loop requiring restitching as follows:
- (1) Use a heavy-duty sewing machine to restitch any loose or broken stitches.
  - (2) Restitch over original stitch pattern using nylon thread, size 3. Overstitch 1/2 inch to lock stitches.
- b. *Replace.* Replace a damaged or missing attachment loop as follows:
- (1) Cut a 20-inch length of 1 3/4-inch wide, Type VIII, cotton webbing and wax ends.
  - (2) Using a marking aid, mark webbing length at a point 5 inches from each end (figure 2-34) and 6 1/2 inches from each end on opposite side.
  - (3) Between two 5-inch marks made in (2) above, roll 112 inch of each webbing edge in to center of webbing width and allow webbing edges to overlap. Using a heavy duty sewing machine and size 3 nylon thread, secure overlapped webbing edges to webbing length by stitching a single row of stitching along the center of webbing overlap and 1 1/2 inches along each rolled edge beyond point of edge overlap (A, figure 2-34). Stitching will be 5 to 8 stitches per inch.
  - (4) Pass one webbing end through vent lines and join webbing ends together above vent lines with a 5-inch long overlap (B, figure 2-34). Ensure the webbing length encircles all vent lines.

**2-22. Attachment Loop. (Bridle Loop) (cont).**

- (5) Using a heavy duty sewing machine with size 3 nylon thread, secure overlapped webbing ends together by stitching a 5-inch long, three-point WW-stitch formation, with a 1/8-inch overstretch on each webbing end. Stitching will be 5 to 8 stitches per inch.
- (6) Remove original attachment loop (bridle loop) by cutting loop webbing as required.

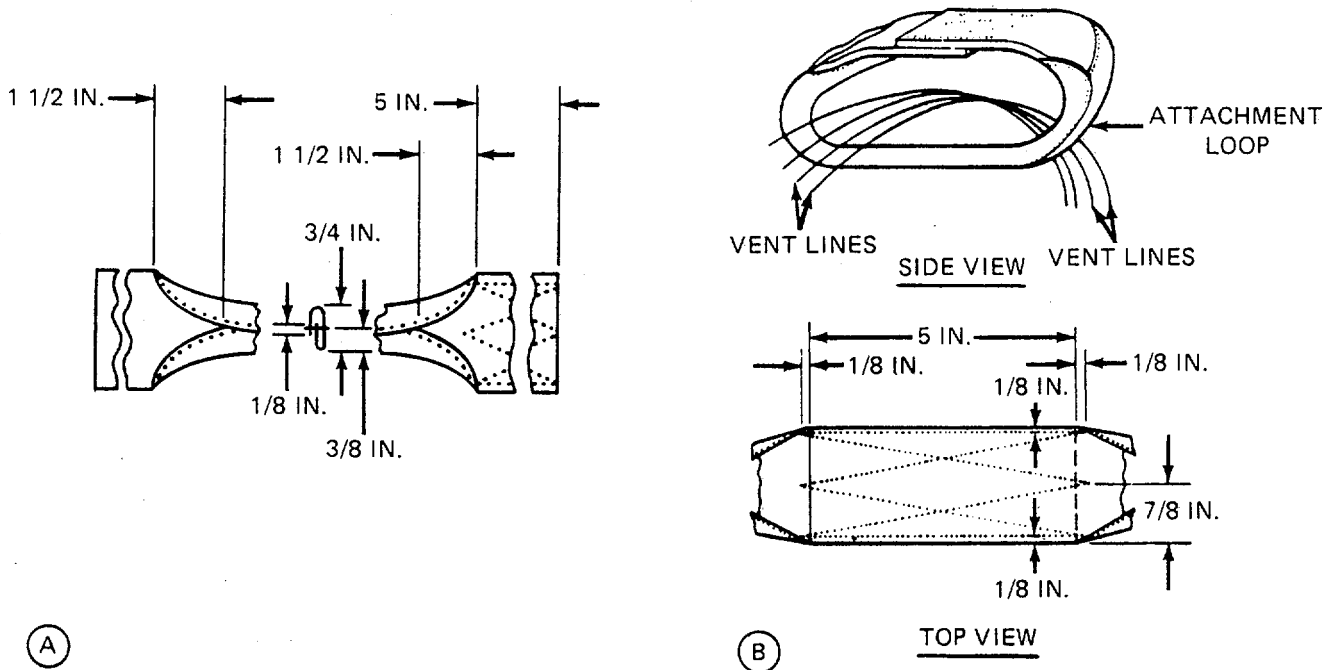

4728-043

Figure 2-34. Attachment Loop Replacement Details.

## 2-23. Vent Lines.

---

This task covers:                    a. Repair                    b. Replace

*Tools:*

Knife, Hot Metal, Item 5, Appendix B  
Knife, Item 4, Appendix B  
Pot, Melting, Item 13, Appendix B  
Sewing Machine, Zig-Zag, Item 17,  
Appendix B  
Shears, Item 14, Appendix B  
Yardstick, Item 24, Appendix B

*Materials/Parts:*

Marking Aid, Item 15116, Appendix D  
Cord, Nylon, Type V, Item 6, Appendix D  
Thread, Nylon, Size E, Item 26/27,  
Appendix D

*Personnel Required:*

43E(10) Parachute Rigger

*Equipment Condition:*

Cleaned, paragraph 2-12  
Inspected, paragraphs 2-9, 2-13  
Unpacked, canopy in proper layout

*Reference:*

Group No. 01, MAC, Section II,  
Appendix B

---

a. Repair. Repair vent lines requiring restitching as follows:

- (1) Use a zig-zag sewing machine to restitch any loose or broken stitches.
- (2) Restitch over original stitch pattern using nylon thread, size E. Overstitch 1/4 inch to lock stitches.

**NOTE**

Replacement of vent lines is accomplished at intermediate (DS) maintenance level only, in accordance with the Maintenance Allocation Chart (MAC), Appendix B.

b. Replace. Replace missing or damaged vent lines as follows:

- (1) Place canopy in proper layout on table and trace damaged vent line from end of original vent line to end. Using marker, mark canopy at each end of vent line.
- (2) Remove damaged vent line by cutting stitching that holds line to canopy at both sides of vent.
- (3) Cut a 20-inch length of type V, coreless nylon cord. Sear and dip ends of cord (para. 2-19).

**2-23. Vent Lines (cont).**

- (4) Position one end of new vent line in exact location formerly occupied by end of old line (figure 2-35).

**NOTE**

Measuring from the outside edge of the upper lateral band, the vent line should extend 4 inches into radial webbing.

- (5) Using a zig-zag sewing machine and nylon thread, size E, stitch new line in place. Begin stitching on line 1/4 inch above upper edge of vent reinforcement tape and sew to 1/4 inch beyond end of line, 7 to 11 stitches per inch and 1/8-inch wide (figure 2-35).
- (6) Pass remaining end of line under other vent lines, and through bridle loop and bridle centering loop as required.
- (7) Position and sew remaining end of line to opposite side of canopy as in steps (4) and (5) above.

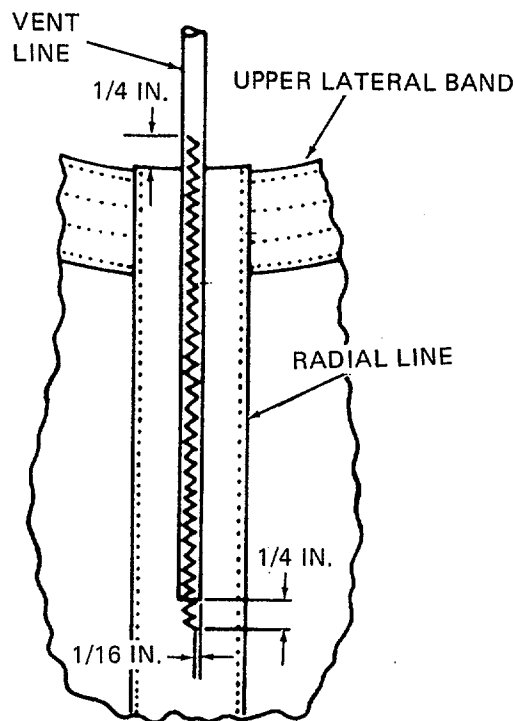

4727-094

*Figure 2-35. Vent Line Replacement Details.*

---

**2-24. Bridle Centering Line.**

---

This task covers: a. Repair b. Replace

---

*Tools:*

Knife, Item 4, Appendix B  
Knife, Hot Metal, Item 5, Appendix B  
Sewing Machine, Zig-Zag, Item 17,  
Appendix B  
Yardstick, Item 24, Appendix B

*Materials/Parts:*

Cord, Nylon, Type V, Item 6, Appendix D  
Thread, Nylon, Size E, Item 26/27,  
Appendix D  
Marking Aid, Item 15/16, Appendix D

*Personnel Require:*

43E(10 Parachute Rigger

*Equipment Condition:*

Cleaned, paragraph 2-12  
Inspected, paragraphs 2-9, 2-13  
Unpacked, canopy laid flat

*Reference:*

Group No. 01, MAC, Section II,  
Appendix B

---

**NOTE**

Repair and/or replacement of the bridle centering line is accomplished at the Intermediate (DS) maintenance level only, in accordance with the Maintenance Allocation Chart (MAC).

a. Repair. Restitch broken or loose thread using a zig-zag sewing machine and size E nylon thread (reference table 2-3). Stitch over original stitch pattern. Overstitch 1/8 inch to lock stitches.

b. Replace. Replace a damaged bridle centering line by fabricating as follows:

- (1) Remove original bridle centering line by cutting stitching which secures each end of line to an attaching vent line.
- (2) Cut an 8-inch length of type V coreless nylon cord and sear ends (para. 2-19).
- (3) Using a marking aid, mark cord length at center and at a point 1/2 inches on each side of center mark (figure 2-36).
- (4) Position cord length in original centering line location and temporarily handtack the cord ends to attaching vent line, using temporary tacking procedures outlined in para. 2-18a. Ensure all vent lines pass freely through loop formed at center of tacked line.

2-24. Bridle Centering Line (cont).

- (5) Using a zig-zag sewing machine and size E nylon thread, secure each end of bridle centering line to attaching vent line by stitching a  $\frac{3}{16}$ -inch wide by  $4\frac{1}{8}$ -inch long row of double-throw zig-zag stitching from  $1\frac{1}{2}$ -inch mark made in (3) above to a point  $\frac{1}{8}$  inch beyond cord end (fig. 2-36). Stitching will be 7 to 11 stitches per inch. Remove the tacking made in (4) above.

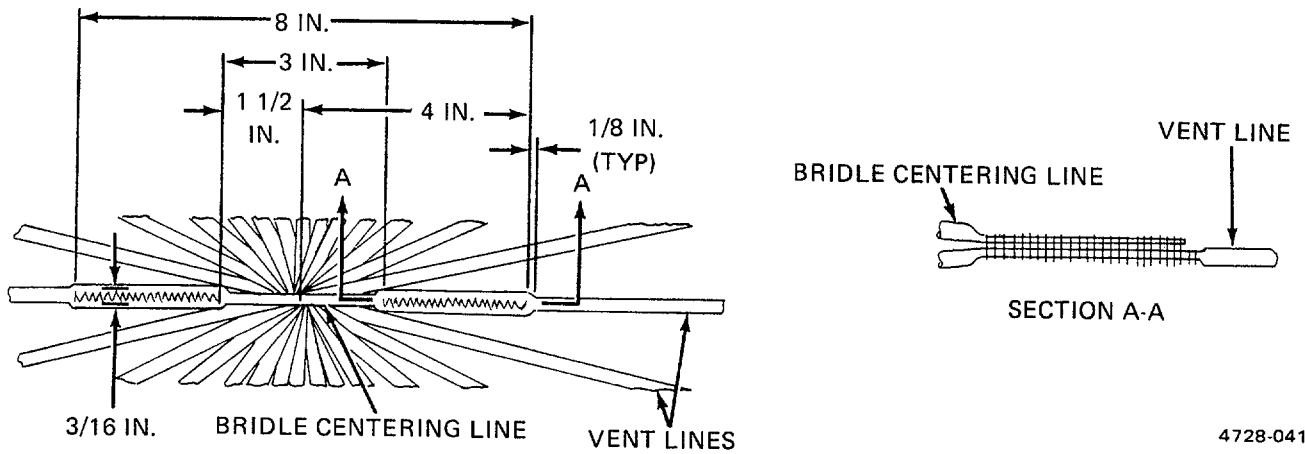

Figure 2-36. Bridle Centering Line Details.

---

**2-25. Vent Reinforcement Band (Upper Lateral Band).**

---

This task covers:       Repair

---

*Tools:*

Knife, Item 4, Appendix B  
Pot, Melting, Item 13, Appendix B  
Sewing Machine, Light Duty, Item 16,  
  Appendix B  
Shears, Item 14, Appendix B

*Materials/Parts:*

Marking Aid, Item 15/16, Appendix D  
Thread, Nylon, Size E, Item 26/27,  
  Appendix D  
Webbing, Nylon, 1-Inch, Tubular, Item 39,  
Appendix D

*Personnel Required:*

43E(10) Parachute Rigger

*Equipment Condition:*

Cleaned, paragraph 2-12  
Inspected, paragraphs 2-9, 2-13  
Unpacked, canopy laid flat

*Reference:*

Group No. 01, MAC, Section II,  
Appendix B

---

a. Restitching. Restitching of vent reinforcement webbing is authorized. Use a light duty sewing machine and size E, nylon thread of contrasting color. Stitch over the original stitch pattern. Lock each row of stitches two inches at each end.

**NOTE**

Vent reinforcement bands may be spliced only once and will not be replaced.

b. Damage Between Radial Seams. Repair as follows:

- (1) Mark vent line position and cut stitching of two vent lines on each side of damaged area, and move lines to one side.
- (2) Smooth canopy around damaged area.
- (3) Cut a piece of 1-inch nylon webbing, long enough to extend 1 inch beyond outside edge of second radial seam on each side of damaged area. Wax the ends of webbing (para. 2-19).
- (4) Center webbing over damaged area. Using a light duty sewing machine and size E, nylon thread, sew webbing in place with four continuous rows of stitching 1/8 inch from edge of webbing, 7 to 11 stitches per inch. Overstitch ends of webbing 1/2 inch (A, figure 2-37).
- (5) Reposition vent lines and sew them in place according to original construction.

**2-25. Vent Reinforcement Band (Upper Lateral Band) (cont).**

c. Damage Extending Into Radial Seam. Repair as follows:

- (1) Mark vent line position and cut stitching of vent line attached to damaged radial seam and the stitching of two vent lines on each side of damaged seam. Move lines to one side.
- (2) Smooth canopy around damaged area.
- (3) Cut a piece of 1-inch wide nylon webbing long enough to extend 1 inch beyond outside edge of second radial seam on each side of damaged area. Wax ends of webbing (para. 2-19).
- (4) Center webbing over damaged area. Using a light duty sewing machine and size E nylon thread, sew webbing in place with four continuous rows of stitching, 1/8 inch from edge of webbing, 7 to 11 stitches per inch. Overstitch ends of webbing 1/2 inch (B, figure 2-37).
- (5) Reposition vent lines and sew in place according to original construction.



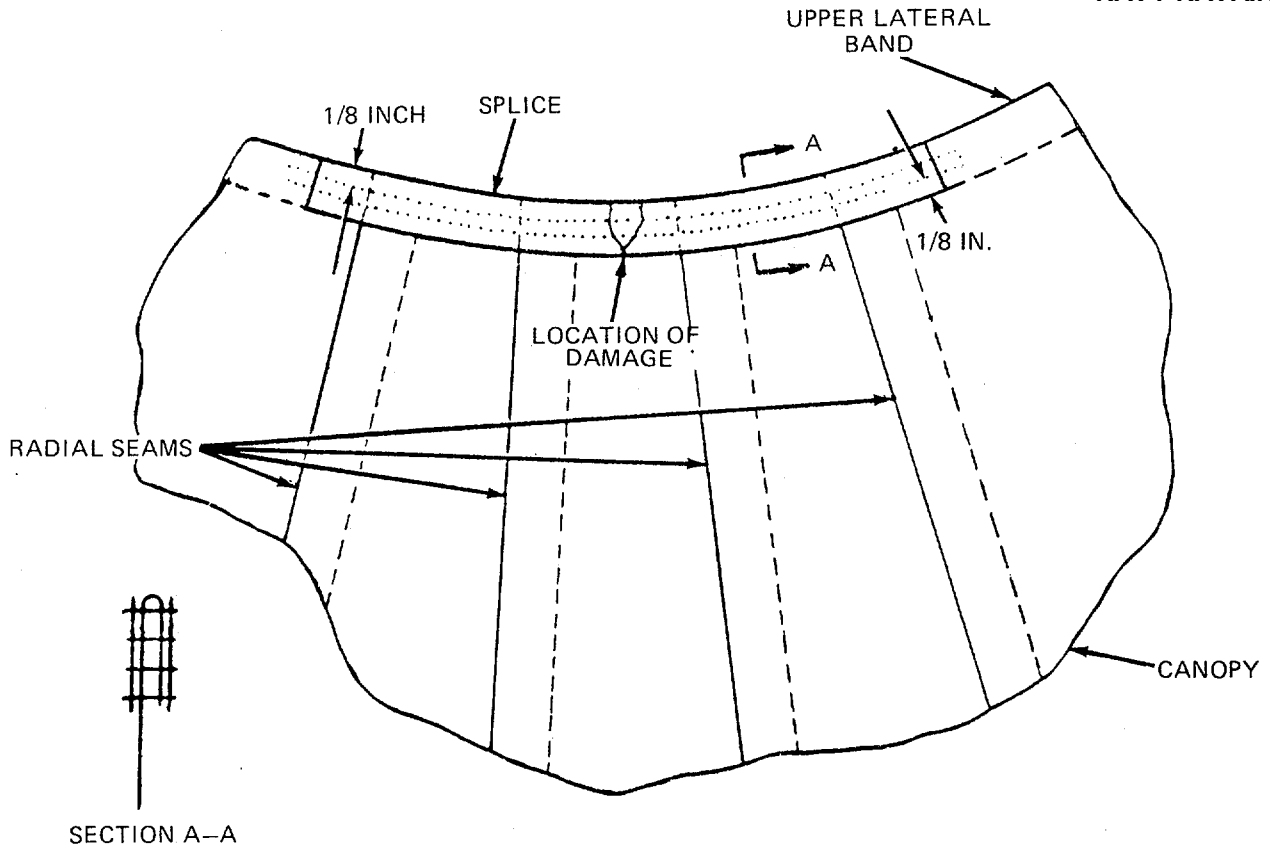

(A) DAMAGE BETWEEN RADIAL SEAMS

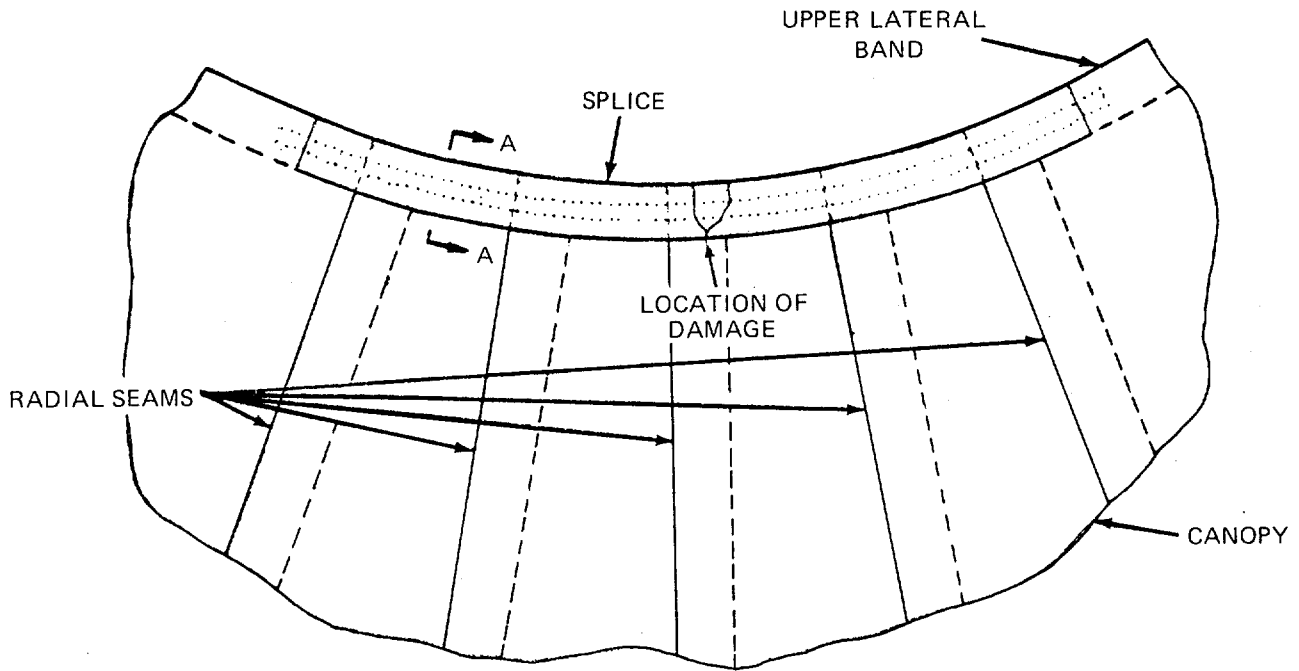

(B) DAMAGE EXTENDING INTO RADIAL SEAM

Figure 2-37. Vent Reinforcement Band Splicing Details.

---

**2-26. Gore Section.**

---

This task covers:      a. Repair      b. Replace

---

*Tools:*

Knife, Item 4, Appendix B  
Needle, Tacking, Item 9, Appendix B  
Shears, Item 14, Appendix B  
Sewing Machine, Light Duty, Item 16,  
Appendix B  
Sewing Machine, Darning, Item 20,  
Appendix B  
Push Pins  
Brush, Stenciling, Item 2, Appendix B

*Materials/Parts:*

Marking Aid, Item 15116, Appendix D  
Thread, Size E, Items 26/27, Appendix D  
Cloth, Nylon, Parachute, 3.5 Ounce,  
Item 5, Appendix D

*Personnel Required:*

43E(10) Parachute Rigger

*Equipment Condition:*

Inspected, paragraph 2-9  
Cleaned, paragraph 2-11  
Parachute laid out on table

*Reference:*

Group No. 01, MAC, Section II,  
Appendix B

---

**NOTE**

Replacement of a gore panel is accomplished at the Intermediate (DS) maintenance level only, in accordance with the Maintenance Allocation Chart (MAC), Appendix B.

a. Repair.

(1) *Restitching.* Stitching and restitching made on parachute canopies should be accomplished with size E nylon thread that is contrasting in color to the fabric being stitched or the original thread being restitched. If contrasting color thread is not available, thread of matching color may be used, providing all other specifications are met. Straight stitching and restitching should be locked by at least two inches at each end of a stitch row, when possible. Restitch directly over the original stitching and follow the original stitch pattern as closely as possible.

- (2) *Darning.* Darn a hole or tear in a gore section which does not exceed 3/4 inch in length or diameter as prescribed in para. 2-18, using size E nylon thread. Each gore section may be darned three times.
- (3) *Patching.* Use a patch to repair holes which exceed 3/4 inch in length or diameter using the sewn patch.
- (a) *Limitations.* The following limitations apply to the 22-foot extraction parachute.

**WARNING**

The limitations prescribed for parachute canopy patching will be stringently adhered to under all circumstances and without any deviations.

- 1 A patch will not be applied to a damaged area that has been previously patched.
- 2 Each gore section is limited to two patches. However, determination should be made as to the most economical method to be used, i.e., two patches versus one large patch or one large patch versus a section replacement. A patch applied to a parachute canopy may extend from radial seam to radial seam.

(b) *Sewn patches.* There are two types of sewn patches authorized, the basic and miscellaneous. A basic patch is used to repair damaged cloth when the affected area is no closer than 1 inch from a radial webbing, upper lateral band or lower lateral band. Should a damaged area be closer than 1 inch to the cited areas, a miscellaneous patch will be made.

**NOTE**

Sewn patches on the canopy will be applied to the inside and may be square or rectangular.

When a miscellaneous canopy patch is used, cut stitching and remove or lay aside items which may interfere with patch application. Refer to applicable item repair paragraph for proper procedures.

- 1 Using marking aid of contrasting color, mark a square or rectangle around area to be patched and ensure one side of marked square or rectangle is parallel to warp or filling of fabric.
- 2 Cut damaged area fabric along lines made in 1 above. Further cut fabric diagonally at each corner to allow a 1/2-inch foldback in raw edges. Cut stitching and lay aside or remove any item which will interfere with miscellaneous patch application.
- 3 Make 1/2-inch foldback on each raw edge. Pin and baste each foldback to complete prepared hole. Basting will be performed using procedures in para. 2-18a.

---

**2-26. Gore Section (cont).**

---

- 4 Using 3.5-ounce nylon cloth, mark and cut a patch 2 1/2 inches wider and longer than inside measurements of prepared hole. Ensure patch material is marked and cut along warp or filling of fabric.
  - 5 Center patch material over prepared hole and ensure warp or filling of patch material matches warp or filling of fabric being patched. Pin patch material in position.
  - 6 Make 1/2-inch foldunder on each edge of patch material and baste patch to prepared area. Basting will be performed using procedures in para. 2-18a.
  - 7 Remove pushpins securing item to the repair table and secure patch by stitching, using a light duty sewing machine and size E nylon thread and applicable details in figure 2-38. Make first row of stitching completely around patch. Invert canopy and make a second row of stitching around prepared hole. Stitching will be 7 to 11 stitches per inch.
  - 8 Replace items removed for miscellaneous patch, as required, in accordance with applicable item procedures.
- (4) *Restenciling.* As required, restencil identification markings using procedures in para. 2-20.

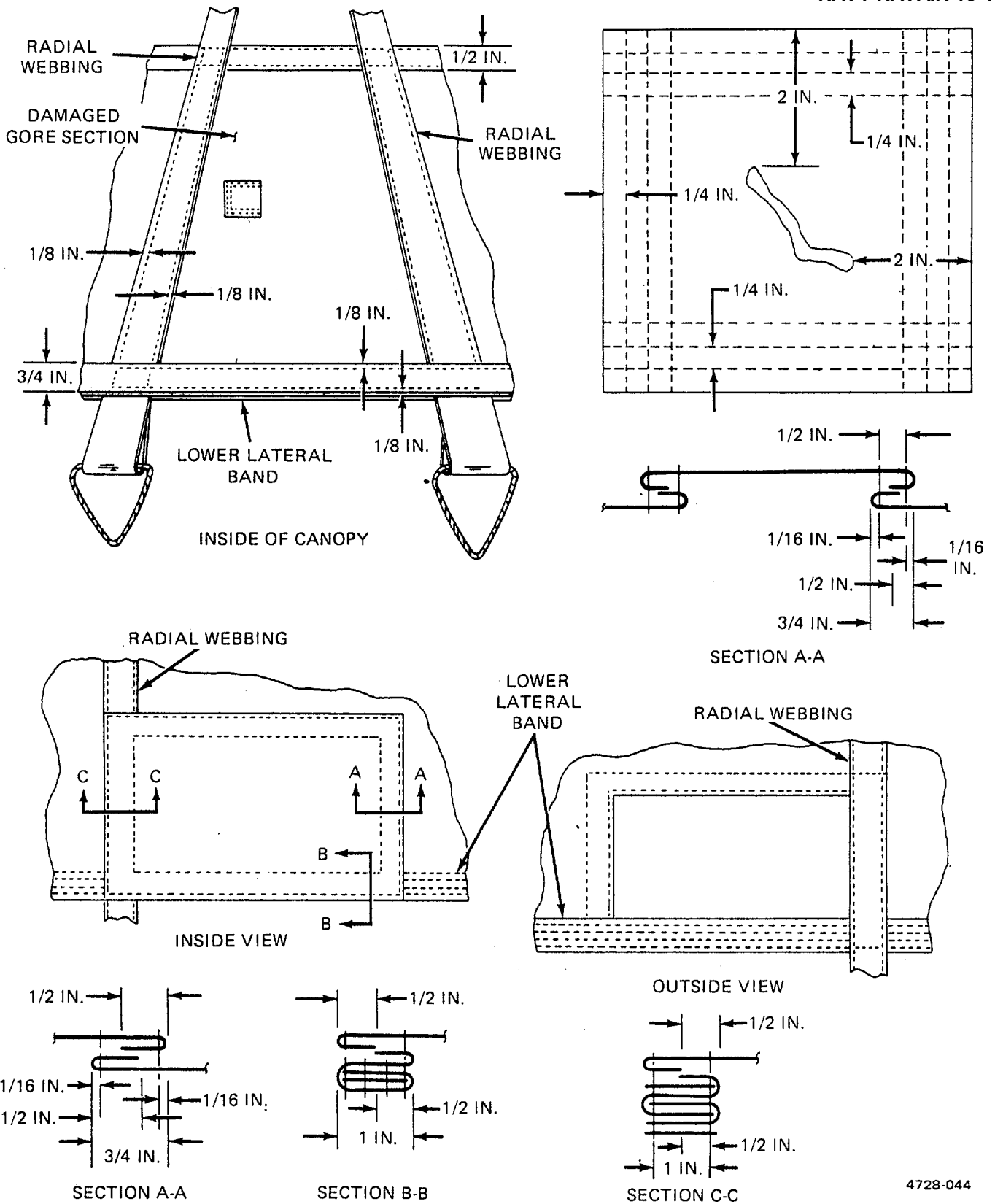

Figure 2-38. Basic and Miscellaneous Patch Application.  
 2-71

2-26. Gore Section (cont).

**NOTE**

Replacement of gore panels can be accomplished only at the intermediate (DS) maintenance level, in accordance with the Maintenance Allocation Chart (MAC), Appendix B.

b. *Replace.* When replacing gore sections, use 3.5-ounce nylon parachute cloth of same color as that being replaced. If the same color cloth is not available, another color may be used. When replacing section 1 of gore 1, stencil gore number and information data block on replacement section. For other gores, stencil gore numbers as necessary using procedures in para. 2-20. A gore section which is damaged beyond repair will be replaced as follows:

(1) *Gore panel replacement (figure 2-39).*

- (a) Invert canopy and locate damaged gore.
- (b) Remove items which may interfere with gore panel replacement by cutting stitching, lay items aside.
- (c) Smooth out and secure surrounding canopy material to table with pushpins. Ensure adjacent lateral and radial webbings are straight and damaged gore panel is not distorted.
- (d) Remove damaged gore panel by cutting material at a point 1 1/2 inch in from adjacent webbing or edge.
- (e) Cut remaining material diagonally at each corner. Fold each raw edge back by 1/2 inch. Pin and baste (para. 2-18) to complete area preparation. Remove pins after basting.
- (f) Cut a piece of 3.5-ounce nylon cloth 2 1/2 inches longer and 1 1/2 inches wider than original gore section (figure 2-39).
- (g) Fold under the selvaged edge of the cloth piece to a width equal to the width of adjacent seam and align the cloth folded edge with the outside edge of adjacent seam or lateral band. Secure the folded edge with pushpins.
- (h) Fold the raw edges of the cloth piece as follows:
  - 1 Fold under the raw edges located adjacent to edge reinforcements and a lateral band, as applicable, and align the folded edges with the outside edges of the reinforcements on band. Secure these folds with pushpins.
  - 2 Fold under the raw edges located along the radial seams and align the folded edges with the outside edges of the radial seams. Secure this fold with pushpins.
- (i) Secure the replacement section cloth to the canopy material by basting along each of the folded edges. Basting will be made in accordance with para. 2-18.
- (j) Remove the pushpins from the edges of the replacement section and secure the section material to the canopy inside using a light duty sewing machine and size E, nylon thread. Stitching will be 7-11 stitches per inch.

(k) Turn the canopy right side out and trim the raw edges of the section material to a point 1/2 inch from the stitching made in j, above.

(l) On the canopy outside, using a light duty sewing machine and size E, nylon thread, stitch completely around the prepared area. Stitching will be 7-11 stitches per inch.

(m) Remove basting, reinvert canopy to outside.

(n) Restore items removed in (b) above. Refer to applicable paragraph for detailed instruction.

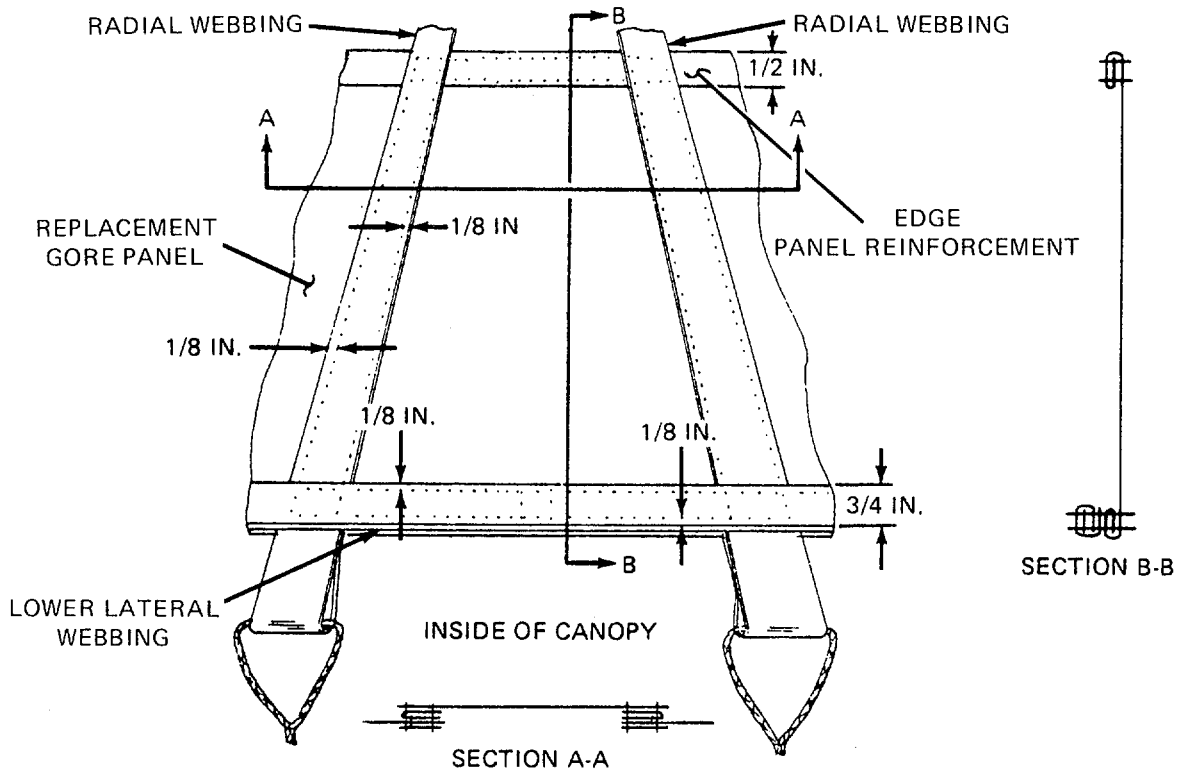

4728-045

**Figure 2-39. Gore Panel Replacement Details.**

---

**2-27. Radial Tape.**

---

This task covers:       Repair

---

*Tools:*

Knife, Item 4, Appendix B  
Knife, Hot Metal, Item 5, Appendix B  
Sewing Machine, Zig-Zag, Item 17,  
Appendix B  
Sewing Machine Light Duty, Item 16,  
Appendix B  
Shears, Item 14, Appendix B  
Pushpins  
Yardstick, Item 24, Appendix B

*Materials/Parts:*

Thread, Nylon, Size E, Item 26/27  
Appendix D  
Webbing, Nylon, Type IV, 1-Inch, Item 36,  
Appendix D

*Personnel Required:*

43E(10) Parachute Rigger

*Equipment Condition:*

Cleaned, paragraph 2-12  
Inspected, paragraphs 2-9, 2-13  
Unpacked, laid flat

*Reference:*

Group No. 01, MAC, Section II,  
Appendix B

---

a. *Restitching.* Restitch radial tape; using a light duty sewing machine and size E nylon thread of contrasting color. Stitch over original pattern, 7 to 11 stitches per inch. Lock each row of stitches two inches at each end. When radial tape stitching has failed and section separation from radial tape has occurred at the leading or trailing edge of ringslots, the repair will be accomplished as follows:

(1) Restitch failure in accordance with original construction. Sew a double throw zig-zag stitching across the width of radial tape at leading/trailing edge of ringslot. Zig-zag stitching should be centered on width of reinforced hem of leading/trailing edge and will be stitched in accordance with para. 2-18d (A, figure 2-40).

(2) As an option, if a zig-zag sewing machine is not available, a box stitch pattern (double row stitching at box ends) 1 1/4 inches in length may be used. Box should start on reinforced hem of leading/trailing edge, approximately 1/8 inches from edge of ring, and proceed in length along radial seam of ring (B, figure 2-40).



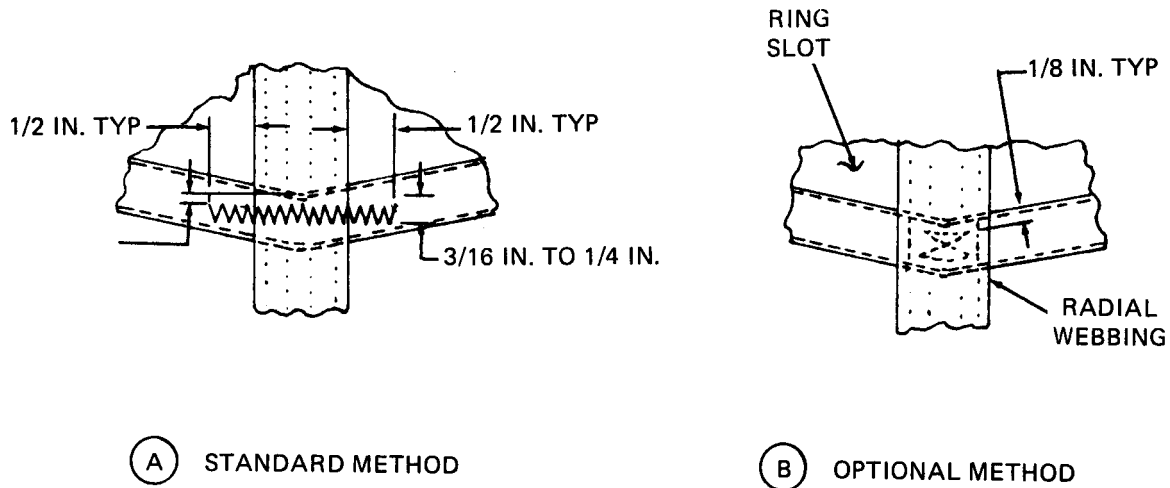

4727-095

**Figure 2-40. Radial Tape Restitching Details.**

b. Splicing. Splice damaged radial tape as follows:

- (1) Place canopy on a repair table with damaged side of radial tape facing up and smooth out canopy material in affected area.

**NOTE**

Radial tape may be spliced one time providing the damaged area does not exceed 12 inches in length. Tape splices may be applied to either or both sides of radial seam.

- (2) Cut a length of Type IV, 1-inch wide nylon webbing, long enough to extend 12 inches beyond each side of damaged area and sear ends as specified in para. 2-19.
- (3) Center webbing length over damaged area. Using a light duty sewing machine and size E nylon thread, secure splice by stitching 7 to 11 stitches per inch splice for full length of splice (figure 2-41).

2-27. Radial Tape.

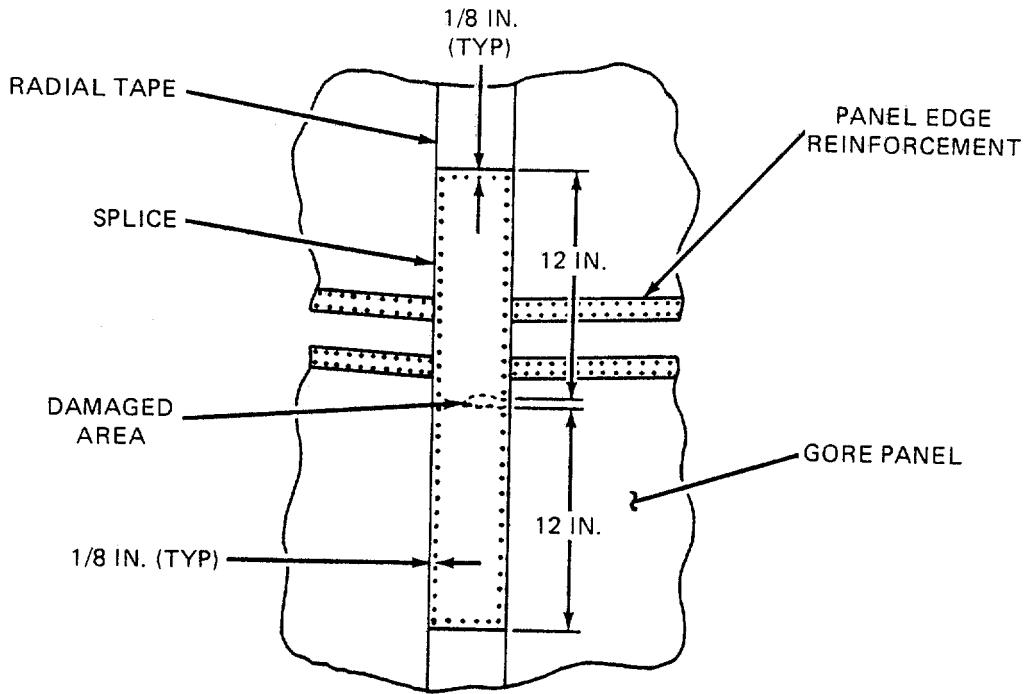

4728-056

Figure 2-41. Radial Tape Splice Details.

---

**2-28. Panel Edge Reinforcement.**

---

This task covers:       Repair

---

*Tools:*

Knife, Item 4, Appendix B  
Knife, Hot Metal, Item 5, Appendix B  
Sewing Machine, Light Duty, Item 16  
Appendix B  
Shears, Item 14, Appendix B  
Yardstick, Item 24, Appendix B

*Materials/Parts:*

Thread, Nylon Size E, Item 26127,  
Appendix D  
Tape, Nylon, Type III, 112-inch, Item 22,  
Appendix D

*Personnel Required:*

43E(10) Parachute Rigger

*Equipment Condition:*

Cleaned, paragraph 2-12  
Inspected, paragraphs 2-9, 2-13  
Canopy laid flat on repair table

*Reference:*

Group No. 01, MAC, Section II,  
Appendix B

---

a. Restitching. Restitching of panel edge reinforcement is authorized. Use a light duty sewing machine and size E, nylon thread of contrasting color. Stitch over the original stitch pattern, 7 to 11 stitches per inch. Lock each row of stitches two inches at each end. Stitch according to paragraph 2-18 and table 2-3.

**NOTE**

The panel edges may be spliced only once and will not be replaced.

b. Splicing. A panel edge reinforcement may be spliced one time as follows.

- (1) Cut a length of 1/2-inch wide, type III nylon tape long enough to extend 6 inches beyond each side of damaged area and sear ends (para. 2-19).
- (2) Center webbing length over damaged area and secure splice by stitching a box-stitch formation, 1/16-inch in from each edge, full length of splice material (figure 2-42). Use a light-duty sewing machine, size E nylon thread, 7 to 11 stitches per inch.

2-28. Panel Edge Reinforcement (cont).

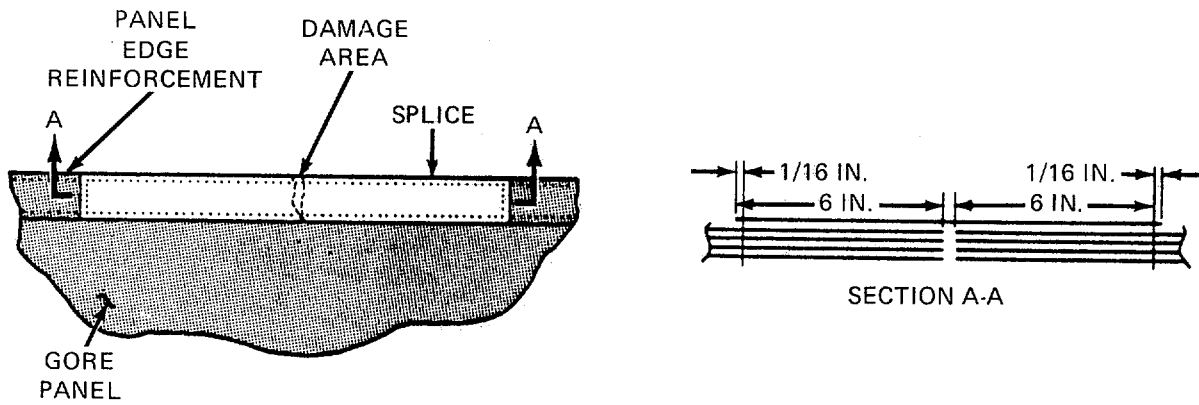

4728-040

Figure 2-42. Panel Edge Reinforcement Splicing Details.

---

**2-29. Skirt Reinforcement (Lower Lateral Band).**

---

This task covers:       Repair

---

*Tools:*

Knife, Item 4, Appendix B  
Knife, Hot Metal, Item 5, Appendix B  
Sewing Machine, Light Duty, Item 16,  
  Appendix B  
Sewing Machine, Zig-Zag, Item 17,  
  Appendix B  
Shears, Item 14, Appendix B  
Yardstick, Item 24, Appendix B

*Materials/Parts:*

Webbing, Nylon, 1-Inch Wide, Tubular  
  Item 39, Appendix D  
Thread, Nylon, Size E, Item 26/27,  
  Appendix D

*Personnel Required:*

43E(10) Parachute Rigger

*Equipment Condition:*

Cleaned, paragraph 2-12  
Inspected, paragraphs 2-9, 2-13  
Unpacked, laying flat on repair table

*Reference:*

Group No. 01, MAC, Section II,  
Appendix B

---

**NOTE**

The skirt reinforcement tape may have one splice between any two suspension lines and can not be replaced.

If the damage is located in a previously spliced area between two suspension lines, the earlier made splice material will be removed before attempting a second splice repair.

a. Stitching and Restitching. Stitch and restitch (para. 2-18) with nylon thread, size E, which contrasts the color of the original stitching and material when possible. Lock all straight stitching by back stitching at least 2 inches. Zig-zag restitching should extend at 1/4 inch into undamaged stitching at each end. Restitch directly over the original stitching. Follow the original stitch pattern as closely as possible.

B Splicing. Splice lower lateral band as follows:

- (1) With damaged side of lower lateral band facing up and affected area of canopy smoothed out, remove previous splice, if required.
- (2) As required, cut and remove original stitching which secures pocket band end to lower lateral band. Fold pocket band loose end away from repair area.
- (3) Cut a length of 1-inch wide tubular nylon webbing long enough to extend 4 inches beyond each side of damaged area. Sear each end of tape (para. 2-19).

**2-29. Skirt Reinforcement (Lower Lateral Band) (cont).**

- (4) Center webbing length over damaged area (figure 2-43) and secure splice by making four rows of continuous stitching using a light duty sewing machine and size E nylon thread. Overstitch each webbing end by 1/2 inch. Stitching will be 7 to 11 stitches per inch.
- (5) Reattach pocket band, if required (para. 2-30).

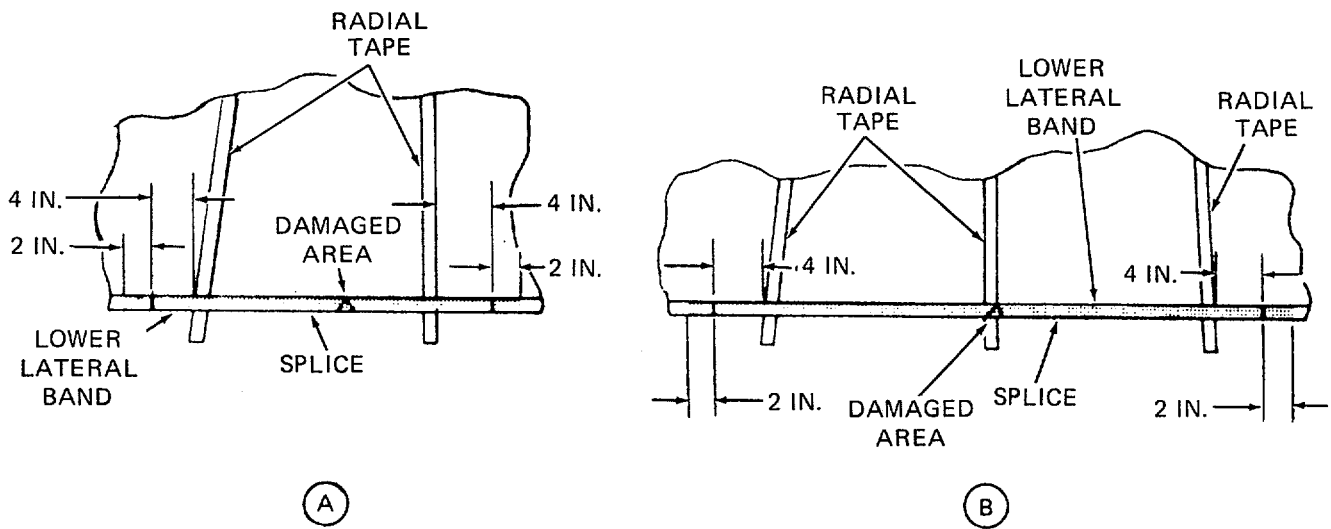

(A)

(B)

- (A) SPLICING DAMAGED AREA BETWEEN RADIAL TAPE LENGTHS.
- (B) SPLICING DAMAGED AREA EXTENDING INTO A RADIAL TAPE.

4728-055

**Figure 2-43. Skirt Reinforcement Splice Details (Lower Lateral Band).**

---

**2-30. Pocket Band.**

---

This task covers:      a. Repair      b. Replace

---

*Tools:*

Knife, Item 4, Appendix B  
Knife, Hot Metal, Item 5, Appendix B  
Sewing Machine, Light-Duty, Item 16,  
Appendix B  
Sewing Machine, Zig-Zag, Item 17,  
Appendix B  
Shears, Item 14, Appendix B  
Yardstick, Item 24, Appendix B

*Materials/Parts:*

Thread, size E, Items 26/27, Appendix D  
Webbing, Nylon, Type IV, 1-Inch, Item 36,  
Appendix D  
Cord, Nylon, Type V, Item 6, Appendix D

*Personnel Required:*

43E(10) Parachute Rigger

*Equipment Condition:*

Cleaned, paragraph 2-12  
Inspected, paragraphs 2-9, 2-13  
Unpacked, laid flat on repair table

*Reference:*

Group No. 01, MAC, Section II,  
Appendix B

---

a. Repair. Stitch and restitch (para. 2-18) with size E thread which matches the color of original stitching, when possible. Lock all zig-zag stitching by over stitching at least 1/2 inch. Restitch directly over the original stitching, following the original stitch pattern as closely as possible.

b. Replace. Replace an unserviceable pocket band by fabricating as follows:

(1) *Tape pocket band.*

- (a) Using a marking aid, mark canopy at each end of original pocket band.
- (b) Cut stitching on both ends of the original pocket band and remove pocket band from canopy skirt.
- (c) Cut an 7 5/16-inch length of 1-inch wide nylon tape, sear ends (para. 2-19).
- (d) Position tape length in original pocket band location.
- (e) Using a light duty sewing machine and size E nylon thread, secure each end of replacement pocket band with a 2-inch long, single-x box stitch formation with two double ends, 1/8-inch in from each edge according to details in figure 2-44. Stitching will be 7 to 11 stitches per inch.

2-30. Pocket Band (cont).

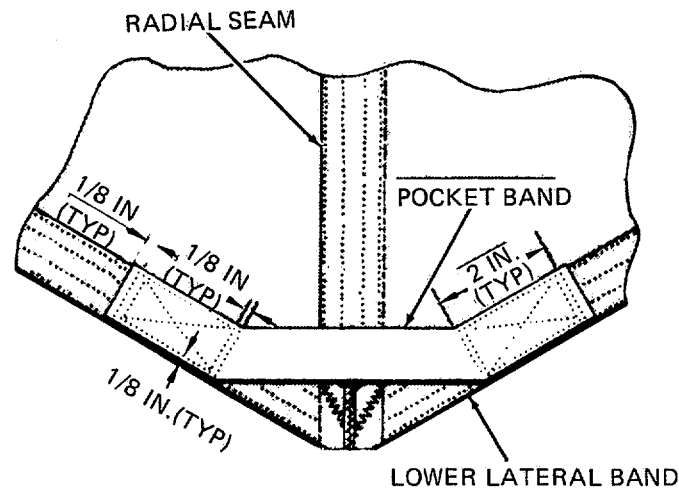

4727-099A

**Figure 2-44. Webbing Type Pocket Band Replacement Details.**

(2) *Cord pocket band.*

- (a) Remove the damaged pocket band and fabricate a replacement item using the procedures in (1) (a) through (d), above, using a 7-5/16-inch length of type V nylon cord.
- (b) Using a zig-zag sewing machine and size E nylon thread, secure each end of the replacement pocket band by stitching a 2 1/4-inch long row of double-throw zig-zag stitching, 7 to 11 stitches per inch, in accordance with the details of figure 2-45.



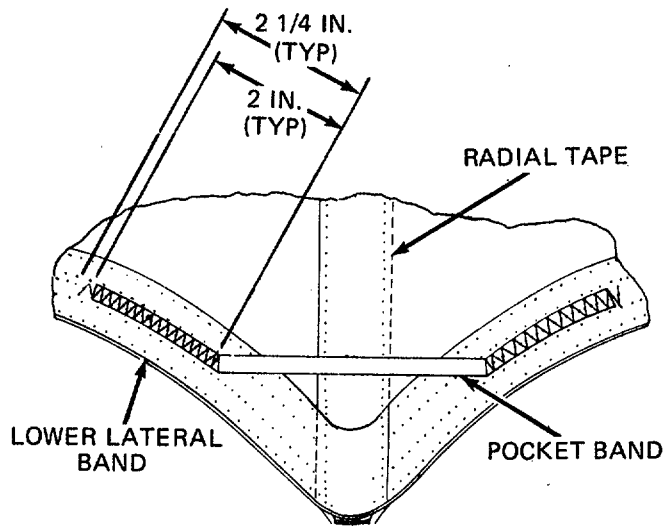

4728-053A

*Figure 2-45. Cord Type Pocket Band Replacement Details.*

---

**2-31. Suspension Line.**

---

This task covers:      a. Repair      b. Replace

---

*Tools:*

Knife, Item 4, Appendix B  
Sewing Machine, Zig-Zag, Item 17,  
Appendix B  
Splicing Aid, Item 25, Appendix B  
Yardstick, Item 24, Appendix B

*Materials/Parts:*

Marking Aid, Item 15116, Appendix D  
Cord, Nylon, Type V, Item 6, Appendix D  
Thread, Nylon, Size E, Items 26/27,  
Appendix D

*Personnel Required:*

43E(10) Parachute Rigger

*Equipment Condition:*

Cleaned, paragraph 2-12  
Inspected, paragraphs 2-9, 2-13  
Canopy laid flat on repair table

*Reference:*

Group No. 01, MAC, Section II,  
Appendix B

---

a. Repair. Stitch and restitch with thread, nylon, size E, that is contrasting in color to the fabric being stitched or original thread being restitched. If contrasting color thread is not available, thread of matching color may be used, providing all other specifications are met. Straight stitch and restitching should be locked by at least two inches at each end of a stitch row when possible. Zig-zag restitching should extend at least 1/4 inch into undamaged stitching at each end, when possible. Restitch directly over the original stitching and follow the original stitch pattern as closely as possible.

**NOTE**

Replacement of suspension lines is accomplished at the Intermediate Maintenance level only, in accordance with the Maintenance Allocation Chart (MAC), Appendix B.

b. Replace. Replace unserviceable suspension line by fabricating as follows:

- (1) Place canopy assembly in proper layout on an inspection table.
- (2) Apply partial tension to suspension lines and trace defective suspension line from connector link to suspension line attaching loop at canopy skirt. Upon completion of line tracing, release line tension.
- (3) Remove damaged suspension line from canopy by cutting formed loop located at upper end of suspension line.
- (4) Cut a length of type V coreless nylon cord 24-inches longer than distance from canopy to connector link. Taper-cut one end (figure 2-46).

- (5) Using a marking aid, mark cord at points 6, 9, and 15 inches from tapered end (figure 2-46).

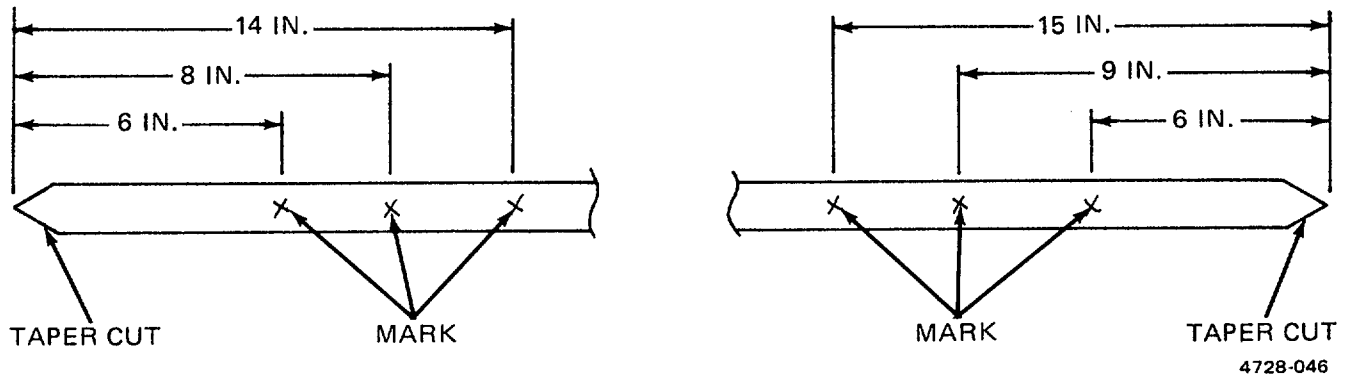

**Figure 2-46. Replacement Suspension Line Construction Details.**

- (6) Pass 7 1/2 inches of tapered cord end through original suspension line attaching loop.
- (7) Insert a splicing aid to cord casing at 15-inch mark and pass inserted aid up through cord casing and to outside at the 9-inch mark.
- (8) Insert cord tapered end into eye of splicing aid.
- (9) Pull splicing aid and cord tapered end down inside cord casing until 6-and 9-inch marks are aligned (figure 2-47).
- (10) Hold alined marks together, pull splicing aid and cord tapered end down and to outside at 15-inch mark.
- (11) Remove cord tapered end from splicing aid and while holding 6-and 9-inch marks together, pull cord at a point below 15-inch mark to allow cord tapered end to withdraw into cord casing.
- (12) Beginning at a point as close as possible to alined 6-and 9-inch marks, use a zig-zag sewing machine and size E nylon thread, secure formed loop by stitching a 1/8-inch wide, 3-inch long row of zig-zag stitching. Stitching will be 7 to 11 stitches per inch.

2-31. Suspension Line (cont).

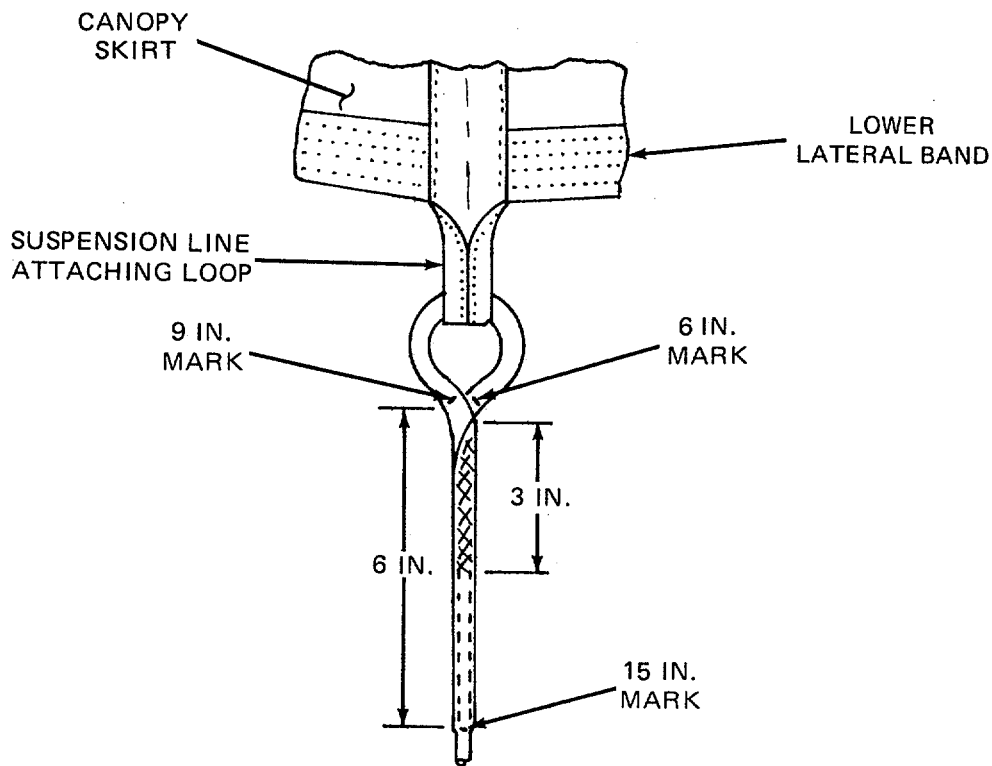

4728-047

**Figure 2-47. Securing Suspension Line at Suspension Line Attaching Loop.**

- (13) Hold attaching loop of an adjacent suspension line and attaching loop of replacement line together tightly at canopy skirt and while lines are under equal tension, trace the length of both lines from attaching loops to the applicable connector link assembly.
- (14) Using a marking aid of contrasting color, mark replacement line length at a point aligned with inside edge of link assembly. Reapply equal tension to both line lengths and check to ensure replacement line length is marked correctly. Release tension lines.
- (15) Cut and remove lower end of original suspension line from connector link assembly and note original location.
- (16) Cut running end of replacement line at a point 7 inches beyond 6-inch mark made in (14) above. Taper-cut 1/2 inch of remaining line end.
- (17) Using an authorized marking aid of contrasting color, mark line length at points 6, 8, and 14 inches from the tapered running end (figure 2-46).

- (18) Pass 7 inches of line through connector link in original line location. Suspension lines shall be attached to riser in numerical sequence (figure 2-48).

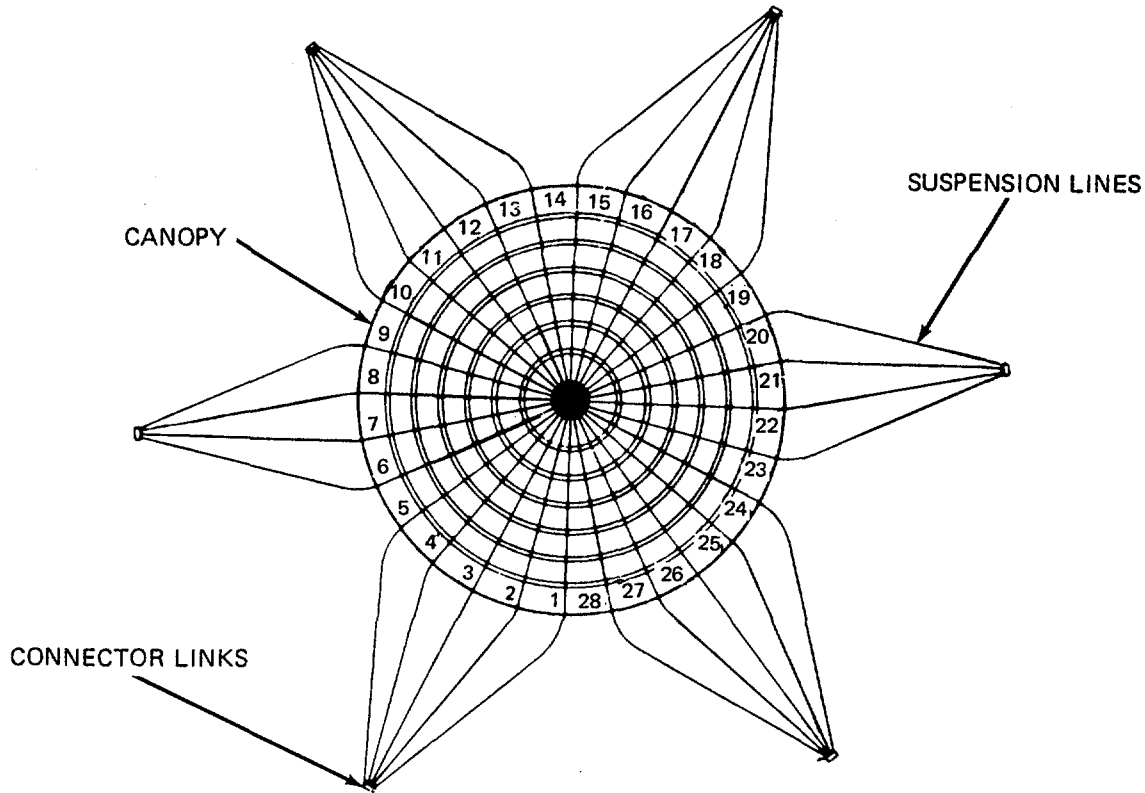

4728-048

**Figure 2-48. Suspension Line Numerical Sequence.**

- (19) Insert a splicing aid to cord casing at the 14-inch mark and pass inserted aid down through cord casing and to outside at the 8-inch mark.
- (20) Insert cord tapered end into eye of splicing aid.
- (21) Pull splicing aid and cord tapered end up inside cord casing until the 6-and 8-inch marks are alined (see figure 2-49).
- (22) Hold alined marks together and pull splicing aid and cord tapered end up and to outside at 14-inch mark.

2-31. Suspension Line (cont).

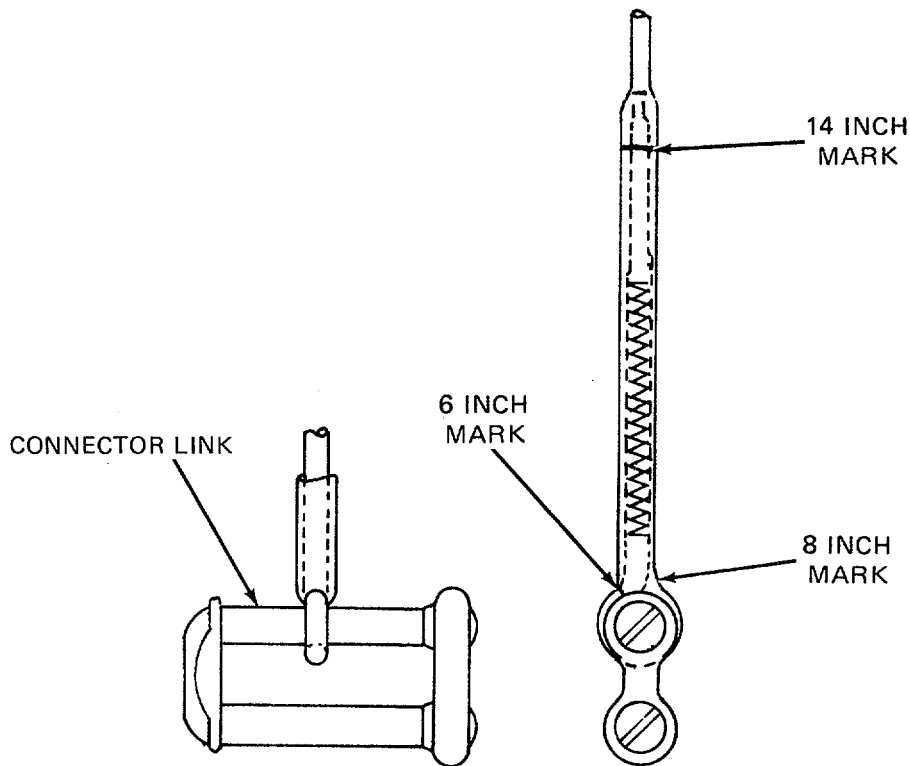

4728-049

**Figure 2-49. Securing Suspension Line to Connector Link.**

- (23) Remove line tapered end from splicing aid and while holding 6-and 8-inch marks together, pull cord at a point above the 14-inch mark to allow line tapered end to withdraw into cord casing.
- (24) Beginning at 6-and 8-inch marks working toward canopy, using a zig-zag sewing machine and size E thread, secure formed loop by stitching a 1/8-inch wide, 3-inch long row of zig-zag stitching. Stitching will be 7 to 11 stitches per inch.
- (25) Trace replacement line from connector link to suspension line attaching loop to ensure proper attachment, position, and sequence.

---

**2-32. Suspension Line Spacer.**

---

This task covers:        Replace

---

*Tools:*

Knife, Item 4, Appendix B  
Knife, Hot Metal, Item 5, Appendix B  
Yardstick, Item 24, Appendix B

*Materials/Parts:*

Cord, Nylon, Type V, Item 6, Appendix D

*Personnel Required:*

43E(10) Parachute Rigger

---

*Equipment Condition:*

Cleaned, paragraph 2-12  
Inspected, paragraphs 2-9, 2-13  
Parachute laid out on table

*Reference:*

Group 01, MAC, Appendix B,  
Section II

Replace a damaged or missing suspension line spacer on a connector link between suspension lines 7-8 or 21-22 by fabricating as follows (figure 2-50):

- a. If applicable, remove original suspension line spacer from between suspension lines by cutting the spacer material.
- b. Cut a 7-inch length of type V coreless nylon cord and sear ends (para. 2-19).
- c. Pass cord length around the applicable connector link bar in original spacer location and secure cord tight against bar with a square knot.

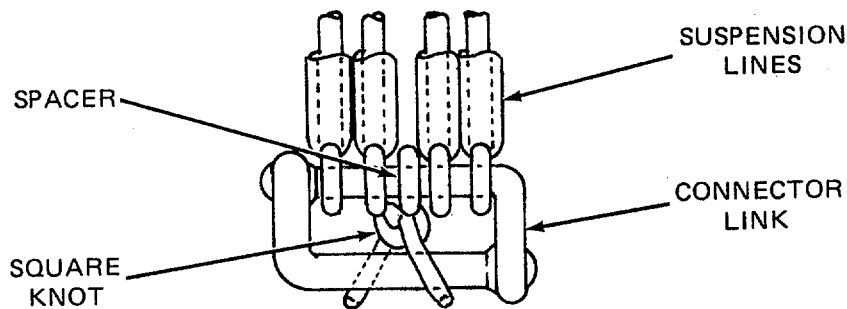

4728-050

**Figure 2-50. Suspension Line Spacer.**

---

**2-33. Connector Link.**

---

This task covers:      a. Repair      b. Replace

---

*Tools:*

Connector Link Separator, Item 23,  
Appendix B  
File, Item 3, Appendix B  
Mallet, Item 8, Appendix B  
Screwdriver, Flat-Tip, Item 22, Appendix B

*Equipment Condition:*

Connector link laid out on table.

*Reference:*

Group No. 01, MAC, Section II,  
Appendix B

*Materials/Parts:*

Cloth, Abrasive, Item 3, Appendix D

*Personnel Required:*

43E(10) Parachute Rigger

---

a. Repair. Repair connector link assembly as follows:

(1) *Cleaning*. Remove burrs, rough spots, rust, or corrosion from a parachute connector link assembly by either filing with a metal file or buffing with abrasive cloth.

(2) *Replacing a locking screw*. Replace a damaged or missing locking screw on a parachute connector link with a serviceable item from stock.

b. Replace. A parachute connector link assembly, regardless of type, which is damaged beyond repair will be replaced with a serviceable L-bar parachute connector link assembly from stock. Use the following procedures:

- (1) Using a flat-tip (slotted-head) screwdriver, remove two locking screws from ends of a replacement parachute connector link assembly and disassemble link (see figure 2-51).
- (2) Using a flat-tip (slotted-head) screwdriver, remove two locking screws from damaged original parachute connector link assembly. Disassemble link assembly, using a link separator, as required. If connector link contains suspension lines, ensure lines are not allowed to slide off damaged link during disassembly process.



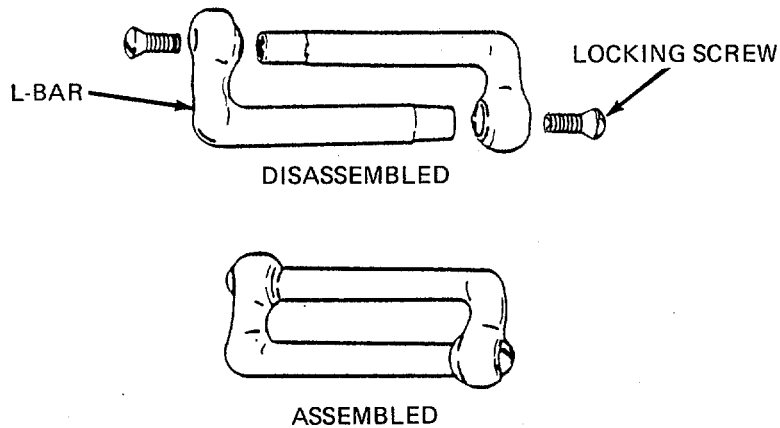

4728-051

*Figure 2-51. Connector Link Assembly.*

- (3) As applicable, position an L-bar of replacement link assembly adjacent to disassembled original link assembly and slide suspension lines from damaged link onto replacement link.
- (4) If required, pass remaining L-bar of replacement link through attaching loop of adjoining component.
- (5) Fit replacement link L-bars together and ensure L-bar leg engagement by tapping end of each L-bar with a mallet.
- (6) As applicable, trace suspension lines from connector link assembly to canopy to ensure lines are properly installed and in correct sequence.

**2-34. Deployment Bag.**

---

This task covers:      a. Inspect      b. Service      c. Repair      d. Replace

---

*Personnel Required:*

43E(10) Parachute Rigger

*Reference:*

Group 02, MAC, Section II,  
Appendix B

*Equipment Condition:*

Unpacked/Detached from Canopy

- a. Inspect. Refer to paragraphs 2-9 and 2-13 for inspection procedures.
- b. Service: Refer to para. 2-12 for cleaning procedures.
- c. Repair. Refer to individual repair procedures.

**CAUTION**

When performing a repair on a 22-foot diameter cargo extraction parachute deployment bag which requires the cutting of stitching or an original part, ensure that adjacent bag material is not damaged during the cutting process.

- d. Replace. An unrepairable deployment bag will be replaced with a serviceable bag from stock.

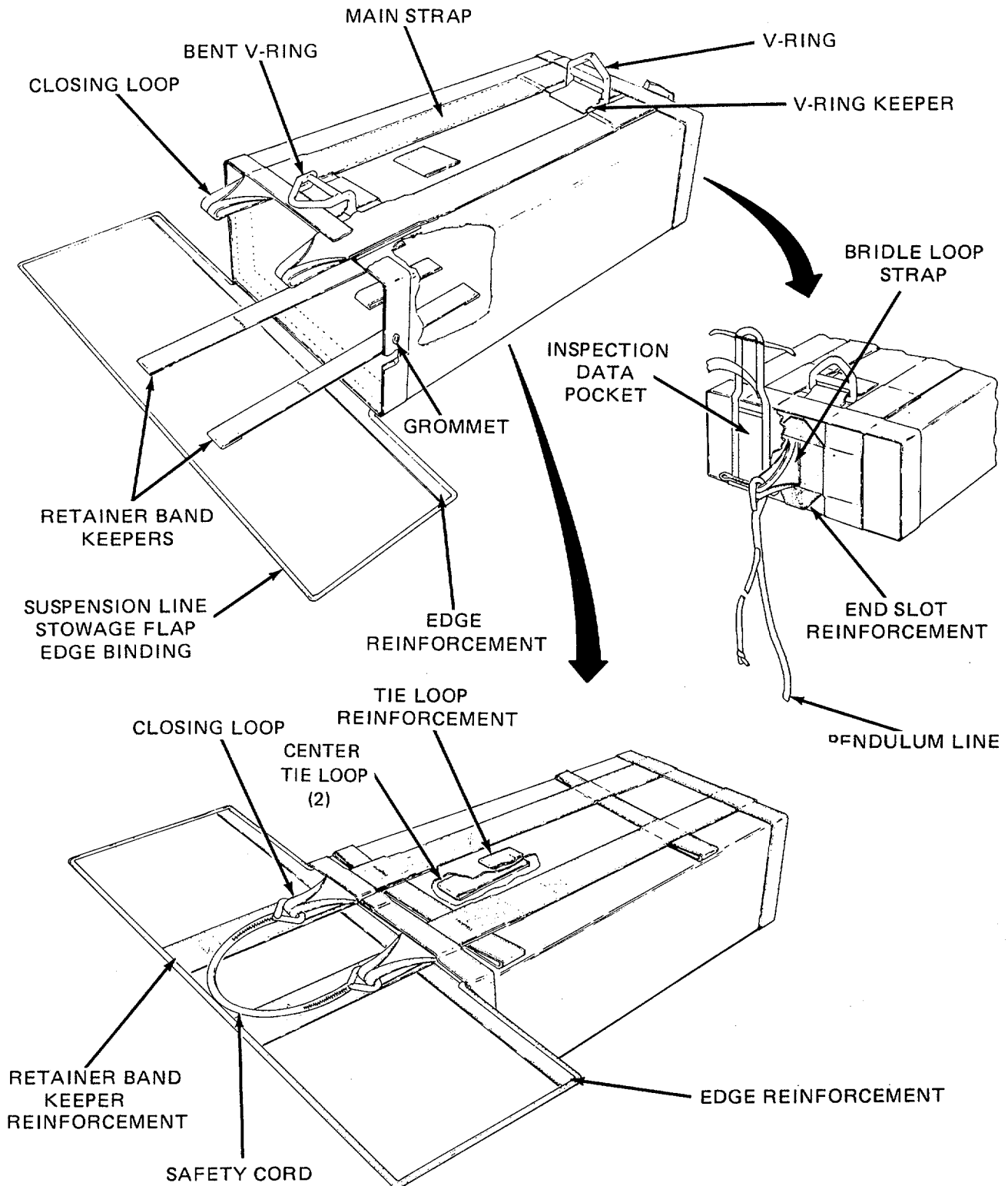

4728-057

Figure 2-52. Deployment Bag.  
 2-93

**2-35. Grommet.**

---

This task covers:      a. Repair      b. Replace

---

*Tools:*

Pliers, Lineman, Item 12, Appendix B  
File, Item 3, Appendix B  
Mallet, Item 8, Appendix B  
Set, Chuck and Die, Item 15, Appendix B  
Sewing Machine, Medium Duty, Item 19,  
Appendix B

*Materials/Parts:*

Cloth, Abrasive, Item 3, Appendix D  
Thread, Nylon, Size E, Items 26/27,  
Appendix D

*Personnel Required:*

43E(10) Parachute Rigger.

*Equipment Condition:*

Cleaned, paragraph 2-12  
Inspected, paragraphs 2-9 and 2-13

*Reference:*

Group No. 02, MAC, Section II,  
Appendix B

---

a. Repair. Repair grommet as follows:

- (1) Remove burrs, rough spots, rust, or corrosion from an installed grommet by filing with a file or by buffing with a crocus cloth.
- (2) Reseat a loose grommet using the procedures listed in para. b.
- (3) If fabric area around original grommet has been damaged, repair area by darning using procedures in para. 2-18c. If darning does not provide an adequate repair, construct a 2 3/4 by 2 3/4 inch sized reinforcement cloth and fold under 1/2 inch on all sides. After removing original grommet (para. b., step 1) sew cloth to inside with size E nylon thread, 7 to 11 stitches per inch, one row of stitches 1/8 inch from outside edge and the second row 3/8 inch from outside edge (figure 2-53).

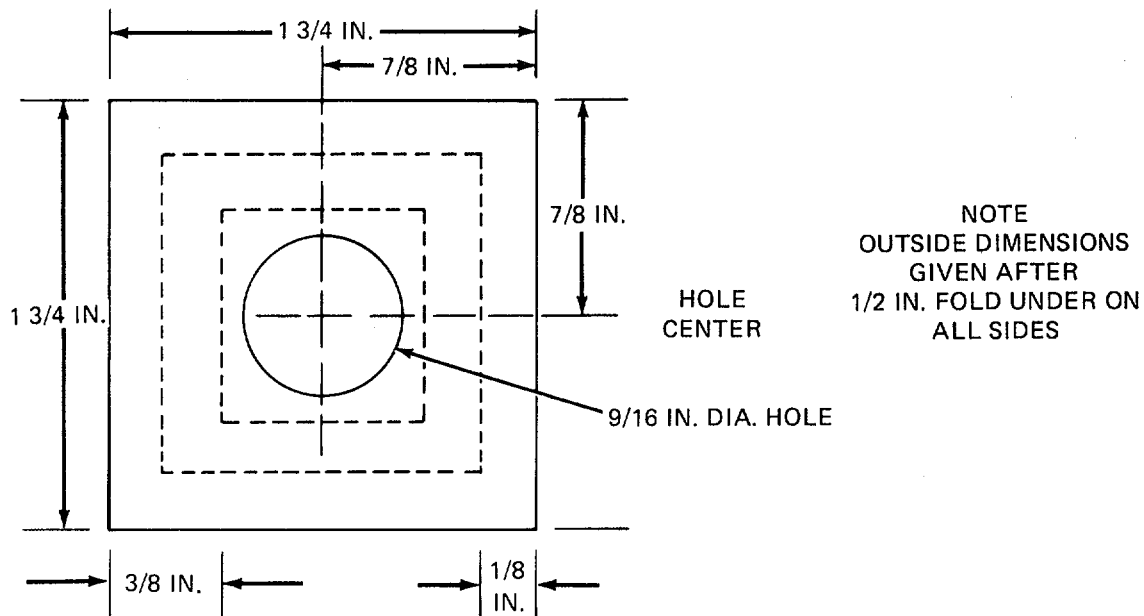

4728-058

Figure 2-53. Fabricating Grommet Reinforcement.

b. *Replace.* Proceed as follows:

(1) Remove original grommet as follows:

- (a) Using a suitable type tool, lift edge of original washer at one point.
- (b) Grip lifted washer edge with lineman pliers and roll washer edge back to lift washer from original grommet. Remove original grommet from material.

(2) *Grommet installation by hand-held method* (figure 2-54).

- (a) Insert barrel of replacement grommet through accommodating hole in material and ensure grommet flange is located on same side of material as original grommet.
- (b) Position grommet on die with barrel facing up and place the washer over grommet barrel.

**NOTE**

When installing a flat grommet by the hand-held method, ensure the grommet barrel and washer are aligned to preclude off-center setting of the grommet.

2-35. Grommet (cont).

- (c) Using a punch and a rawhide mallet or other-non-steel impact device, spread grommet barrel by hammering until barrel collar is rolled down smooth on washer. If grommet barrel splits during hammering process, remove and replace installed grommet with a serviceable item from stock, repeating procedures in steps (a) and (b), above.
- (d) Check seating of grommet. If grommet can be turned by hand, repeat step (c) until grommet is firmly seated.

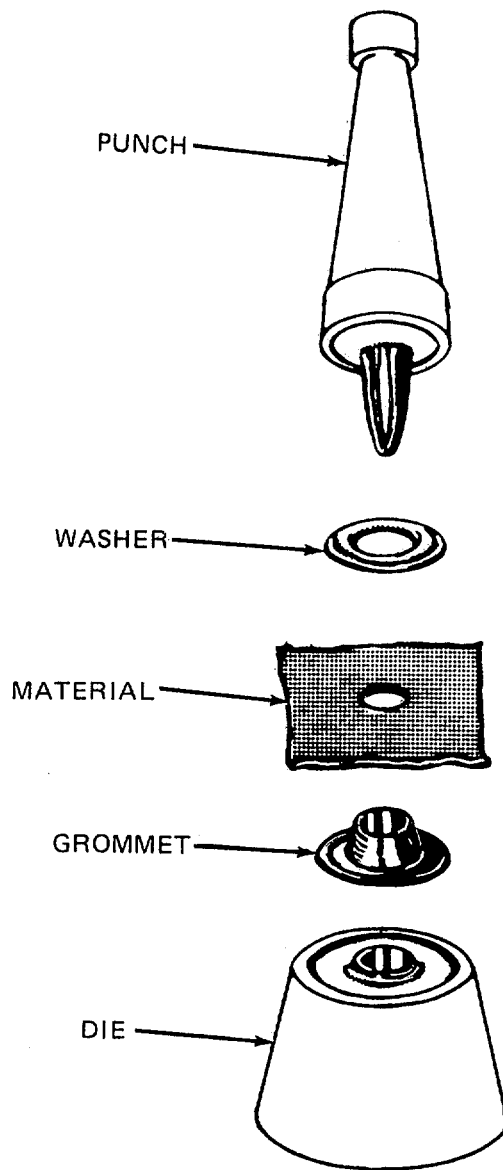

4728-059

Figure 2-54. Grommet Installation by Hand-Held Method.

(3) *Grommet installation by hand-operated press.*

- (a) Install 1/4-inch chuck and die in hand-operated press, secure locking screws with hex wrench (figure 2-55).

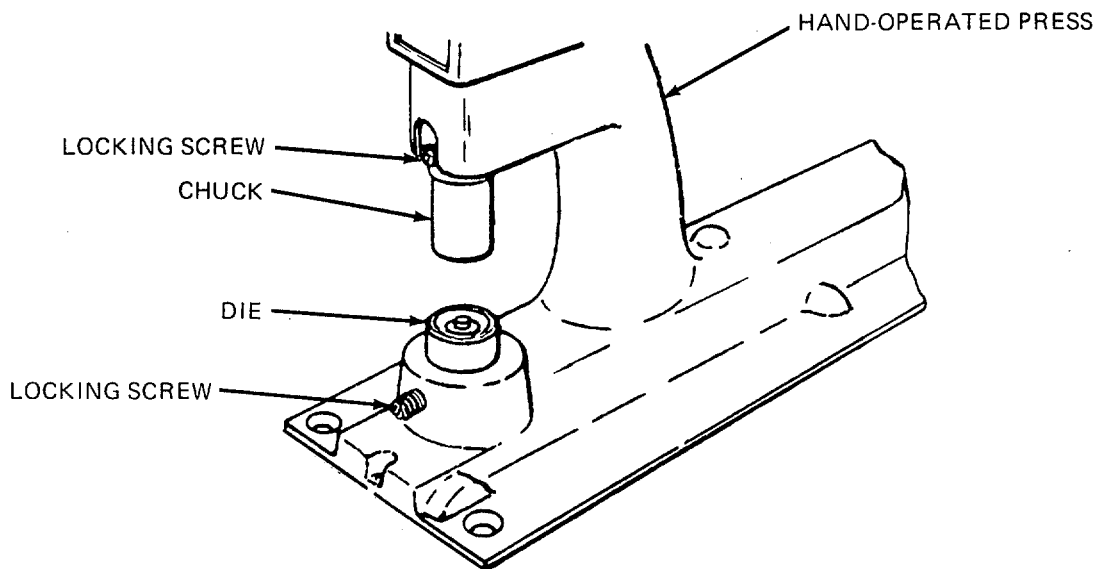

4728-060

*Figure 2-55. Chuck and Die Installed in Hand-Operated Press.*

- (b) Insert barrel of replacement grommet through hole in material. Ensure grommet flange is on same side of material as original grommet (A, figure 2-56).
- (c) Position grommet on die in press with barrel facing up, place replacement washer over barrel (B, figure 2-56).
- (d) Depress handle or foot pedal, spreading grommet barrel until collar is rolled down smoothly on washer (C and D, figure 2-56).
- (e) Check grommet for firm seating. If grommet can be turned by hand, repeat step (d) above, until a firm seat is achieved.

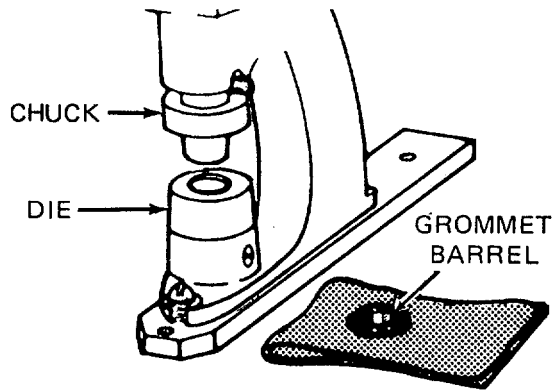

A. GROMMET BARREL INSERTED IN MATERIAL HOLE

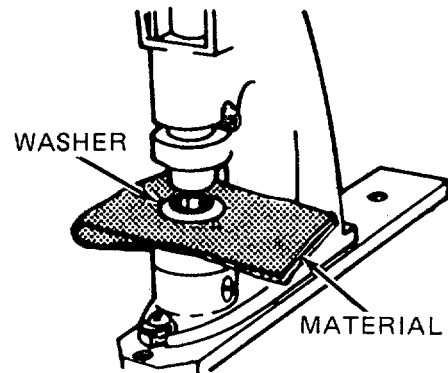

B. WASHER PLACED OVER GROMMET BARREL

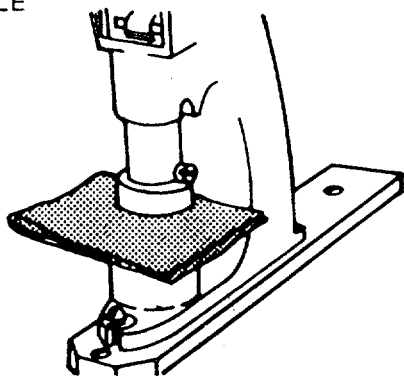

C. PRESS ACTIVATED TO SEAT THE GROMMET

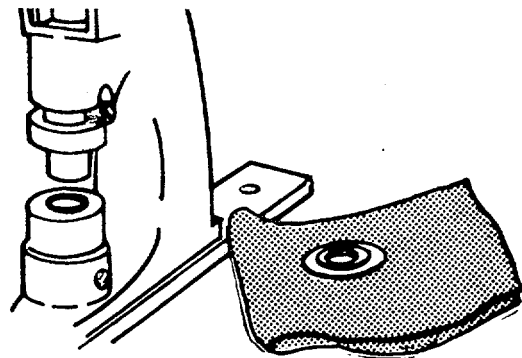

D. GROMMET INSTALLATION COMPLETED

4728-061

Figure 2-56. Flat Grommet Installation by Hand- or Foot-Operated Press, Typical.



**2-36. Deployment Bag Retainer Band Keeper.**

---

This task covers:      a. Repair      b. Replace

---

*Tools:*

Knife, Item 4, Appendix B  
Knife, Hot Metal, Item 5, Appendix B  
Sewing Machine, Medium Duty, Item 19,  
Appendix B  
Shears, Item 14, Appendix B  
Yardstick, Item 24, Appendix B

*Materials/Parts:*

Thread, Nylon, Size FF, Item 28/29,  
Appendix D  
Webbing, Nylon, Type IV, 1-Inch, Item 36,  
Appendix D

*Personnel Required:*

43E(10) Parachute Rigger

*Equipment Condition:*

Cleaned, paragraph 2-12  
Inspected, paragraphs 2-9, 2-13  
Laid out on work table

*Reference:*

Group No. 02, MAC, Section II,  
Appendix B

---

a. Repair. Stitch and restitch with size FF thread which matches the color of the original stitching, when possible. Lock all straight stitching by backstitching at least 1/2 inch. Restitch by overstitching each end of the stitch formation by 1/2 inch. Restitch directly over the original stitching, following the original stitch pattern as closely as possible. Stitching will be in accordance with para. 2-18 and table 2-3.

b. Replace. Replace a damaged retainer band keeper by fabricating as follows:

- (1) Remove original retainer band keeper by cutting stitching securing keeper webbing to suspension line stowage flap and inside of bag bottom panel (figure 2-57).
- (2) Cut a 25 1/2-inch length of 1-inch wide type IV nylon webbing, sear ends (para. 2-19).
- (3) Make a 1-inch long turnunder on each end of webbing length and position webbing in original keeper location with turnunders facing down.
- (4) Using criteria in figure 2-57, secure each end of webbing length to deployment bag by stitching a single-X box stitch formation with one double end. Stitch four lateral rows of stitching across webbing width at three points to form four equal sized loops in webbing length.

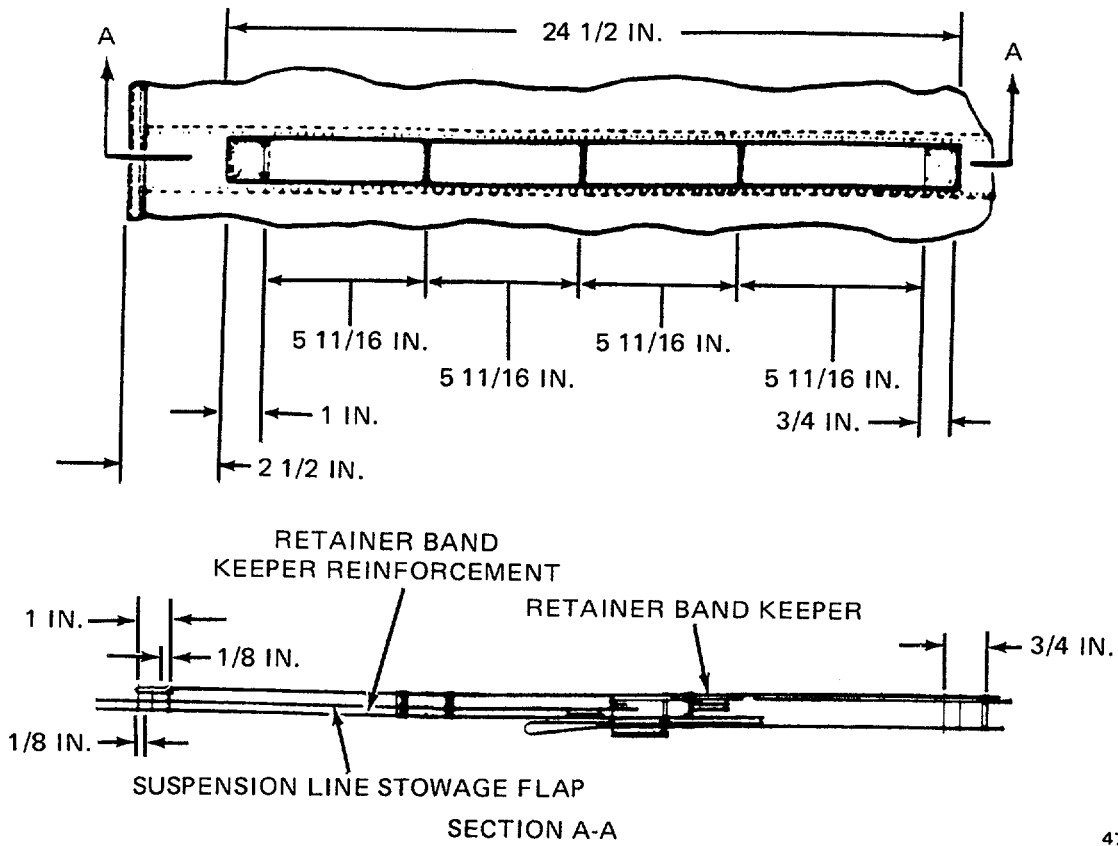

4728-062

Figure 2-57. Retainer Band Keeper Replacement.

---

**2-37. Deployment Bag Retainer Band Keeper.**

---

This task covers:      a. Repair      b. Replace

---

*Tools:*

Knife, Item 4, Appendix B  
Pot, Melting, Item 13, Appendix B  
Sewing Machine, Light-Duty, Item 16,  
Appendix B  
Sewing Machine, Zig-Zag, Item 17,  
Appendix B  
Shears, Item 14, Appendix B  
Splicing Aid, Item 25, Appendix B  
Yardstick, Item 24, Appendix B

*Materials/Parts:*

Cord, Nylon, Type IV, Item 7, Appendix D  
Marking Aid, Item 15116, Appendix D  
Thread, Size FF, Nylon, Item 28129,  
Appendix D  
Thread, Nylon, Size E, Item 26127, Appendix D  
Tape, Cotton, Type I, 1 112-Inch, Item 20  
Appendix D

*Personnel Required:*

43E(10) Parachute Rigger

*Equipment Condition:*

Cleaned, paragraph 2-12  
Inspected, paragraphs 2-9, 2-13  
Laid out on work table

*Reference:*

Group No. 02, MAC, Section II,  
Appendix B

---

a. Repair. Stitch and restitch with size FF thread which matches the color of the original stitching, when possible. Lock all straight stitching by backstitching at least 112 inch. Restitch by overstitching each end of the stitch formation by 1/2 inch. Restitch directly over the original stitching, following the original stitch pattern as closely as possible. Stitching will be in accordance with para. 2-18 and table 2-3.

b. Replace. Replace a damaged retainer line by fabricating as follows:

- (1) Remove original bag retainer line by cutting line at retainer line attaching loop on bag inside.

**CAUTION**

Do not cut or break the threads in the type IV coreless nylon cord casing while fabricating a bag retaining line.

- (2) Cut a 39-inch length of type IV coreless nylon cord and taper-cut each end by 1/2 inch.
- (3) Using a marking aid, mark one end of cord length at points 4, 9, and 13 112 inches from one end, and 4, 17, and 21 112 inches from the other end (figure 2-58).

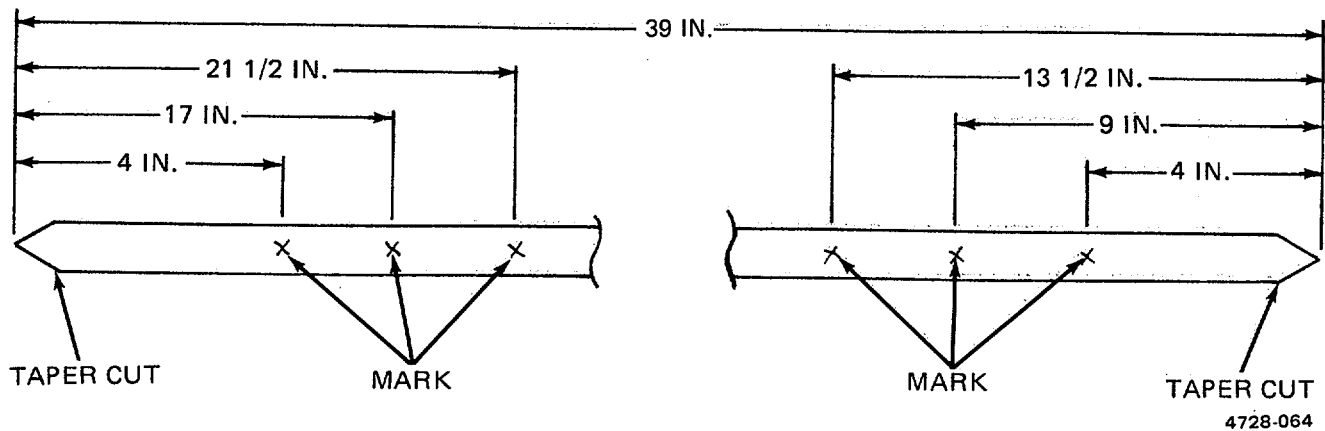
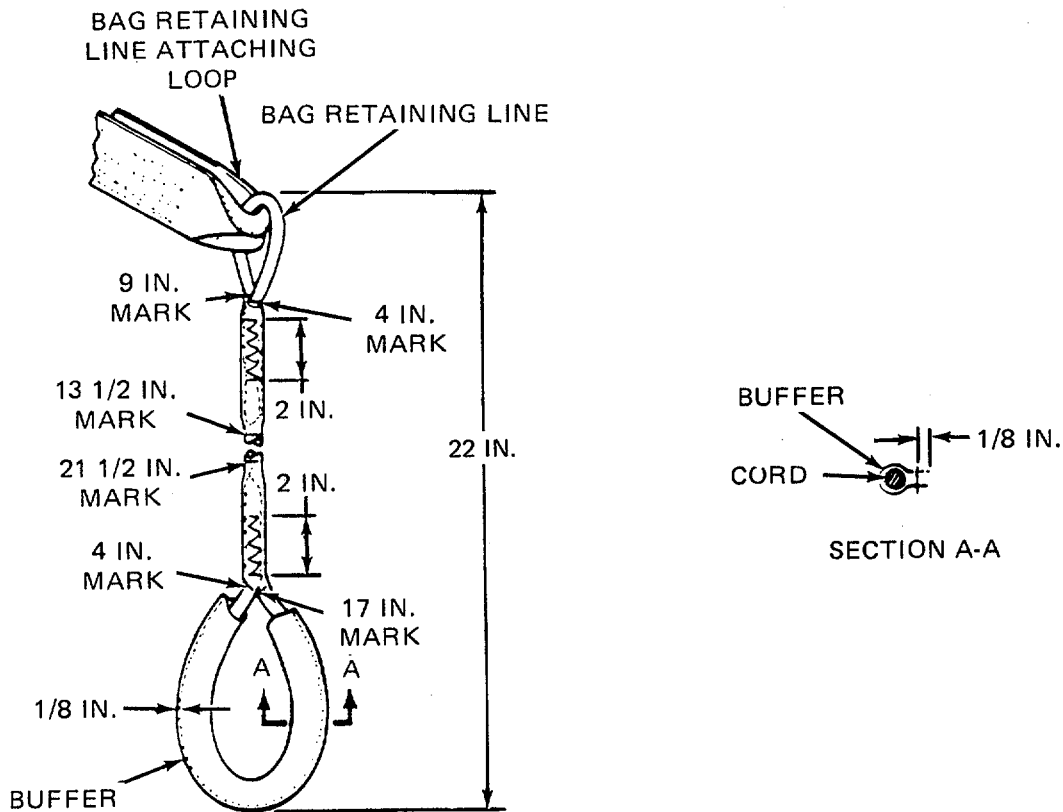

Figure 2-58. Replacement Retainer Line Construction Details.

- (4) Pass the cord end marked at 4, 9, and 13 1/2 inches through retainer line attaching loop on bag inside and center loop between 4- and 9-inch marks (figure 2-59).
- (5) Insert a splicing aid into cord casing at the 13 1/2-inch mark and work splicing aid through cord casing to outside at 9-inch mark.
- (6) Attach tapered cord end nearest 4-inch mark to splicing aid and work aid back through cord casing until 4- and 9-inch marks are aligned.
- (7) Hold alined marks together and work splicing aid and tapered cord end to outside at 13 1/2-inch mark.
- (8) Remove tapered cord end from splicing aid. While holding alined 4- and 9-inch marks together, stretch cord length allowing tapered cord end to recede inside cord casing.
- (9) Secure formed line loop by stitching a 3/16-inch wide by 2-inch long row of double-throw zig-zag stitching according to details in figure 2-58, using size FF nylon thread, 7 to 11 stitches per inch.
- (10) Cut a 12-inch length of 1 1/2-inch wide, type I cotton tape and wax the ends in accordance with para. 2-19.
- (11) Fold tape length in half lengthwise and aline edges. Secure alined edges by stitching a 12-inch long row of stitching, 1/8 inch in from alined edges using a light-duty sewing machine and size E nylon thread. Stitching will be 7 to 11 stitches per inch.
- (12) Pass cord length free end through buffer made in (11), above, and locate buffer between 4- and 17-inch marks.



4728-065

Figure 2-59. Deployment Bag Retainer Line Replacement Details.

- (13) Insert a splicing aid into cord casing at 21 1/2-inch mark and work splicing aid through cord casing to outside at 17-inch mark.
- (14) Attach cord tapered free end to splicing aid and work aid back through cord casing until 4- and 17-inch marks are aligned.
- (15) Hold alined marks together and work splicing aid with attached cord end to outside at 21 1/2-inch mark.
- (16) Remove tapered cord end from splicing aid. While holding alined 4- and 17-inch marks together, stretch cord length to allow tapered cord end to recede into cord casing.
- (17) Secure second line loop using procedure in (9) above and specifics in table 2-3.

## 2-38. Deployment Bag Closing Loop.

---

This task covers:      a. Repair      b. Replace

---

*Tools:*

Knife, Item 4, Appendix B  
Knife, Hot Metal, Item 5, Appendix B  
Sewing Machine, Medium Duty, Item 19  
Appendix B  
Sewing Machine, Heavy Duty, Item 18,  
Appendix B  
Shears, Item 14, Appendix B  
Yardstick, Item 24, Appendix B

*Materials/Parts:*

Marking Aid, Item 15116, Appendix D  
Thread, Nylon, Size FF, Item 28/29,  
Appendix D  
Webbing, Nylon, Type VIII, Item 37,  
Appendix D

*Personnel Required:*

43E(10) Parachute Rigger

*Equipment Condition:*

Cleaned, paragraph 2-12  
Inspected, paragraphs 2-9, 2-13  
Laid out on work table

*Reference:*

Group No. 02, MAC, Section II,  
Appendix B

---

a. *Repair.* Stitch and restitch with size FF thread which matches the color of the original stitching, when possible. Lock all straight stitching by backstitching at least 1 1/2 inch. Restitch by overstitching each end of the stitch formation by 1 1/2 inch. Restitch directly over the original stitching, following the original stitch pattern as closely as possible. Stitch according to para. 2-18 and table 2-3.

b. *Replace.* Replace a damaged bag closing loop by fabricating as follows:

- (1) Remove original closing loop by cutting loop webbing flush along edge of bag end reinforcement.
- (2) Cut an 11-inch length of 1 23/32-inch wide, type VIII nylon webbing, sear ends according to para. 2-19.
- (3) Mark webbing length at a point 3 1/2 inches from each end (A figure 2-60).
- (4) Between two marks made in (3) above, roll webbing edges in to center of webbing width and secure each rolled edge by stitching a 4-inch long row of stitching according to details in A, figure 2-66, using a medium-duty sewing machine and size FF nylon thread. Stitching will be 7 to 11 stitches per inch.
- (5) Double webbing length with rolled edges facing out and align webbing ends.

- (6) Position formed loop in original closing loop location with aligned webbing end placed over applicable main strap and bag end reinforcement. Secure webbing ends, bag end reinforcement and main strap by stitching a 3 1/8-inch long single-X box-stitch formation, with two double ends, according to the details in B, figure 2-60, using a heavy-duty sewing machine and size FF nylon thread. Stitching will be 7 to 11 stitches per inch.

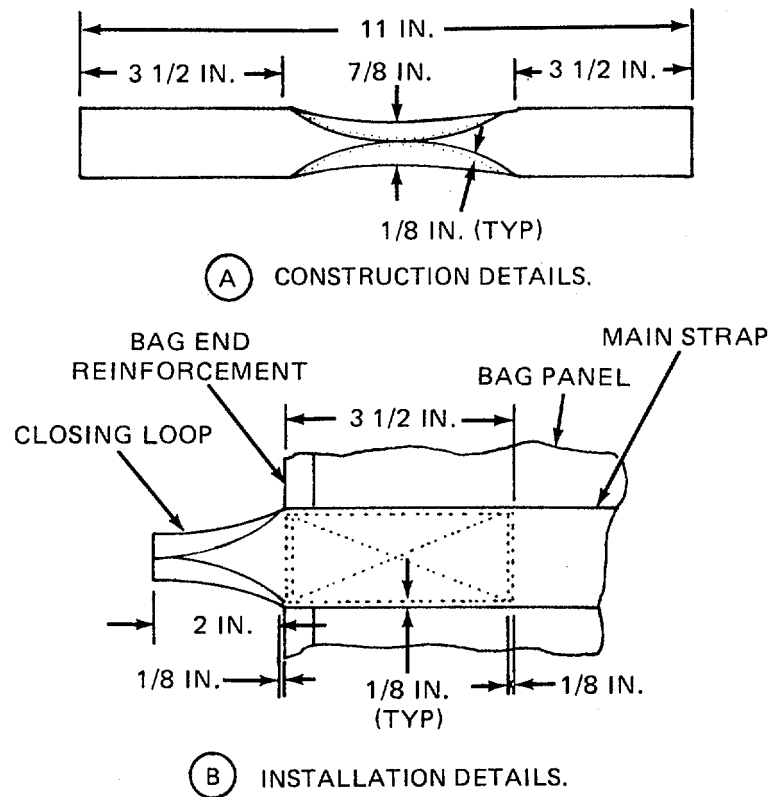

Figure 2-60. Closing Loop Replacement Details.

**2-39. Inspection Data Pocket.**

---

This task covers:      a. Repair      b. Replace

---

*Tools:*

Sewing Machine, Medium Duty, Item 19,  
Appendix B  
Sewing Machine, Zig-Zag, Item 17,  
Appendix B

*Materials/Parts:*

Thread, Nylon, Size E, Items 26/27,  
Appendix D  
Thread, Cotton, Ticket 8/7, Item 25,  
Appendix D  
43E(10) Parachute Rigger

*Personnel Required:*

43E(10) Parachute Rigger

*Equipment Condition:*

Cleaned, paragraph 2-12  
Inspected, paragraphs 2-9, 2-13  
Laid out on work table

*Reference:*

Group No. 02, MAC, Section II,  
Appendix B

---

a. Repair. Stitch and restitch with size E nylon thread which matches the color of original stitching, when possible. Lock all straight stitching by backstitching at least 1/2 inch. Restitch directly over the original stitching, following original stitch pattern as closely as possible.

b. Replace. Replace a missing or unserviceable parachute inspection data pocket (log record pocket) as follows (figure 2-61):

- (1) Position parachute inspection data pocket on bottom of deployment bag with pocket bottom edge squared with end slot reinforcement and retainer band keeper.
- (2) Hand tack pocket to main strap at four corners using a tacking needle and two turns of doubled, waxed ticket 8/7 thread. Wax thread in accordance with para. 2-19.
- (3) Secure tacking ends with a surgeon's knot and a locking knot. Trim ends to 1/4 inch.



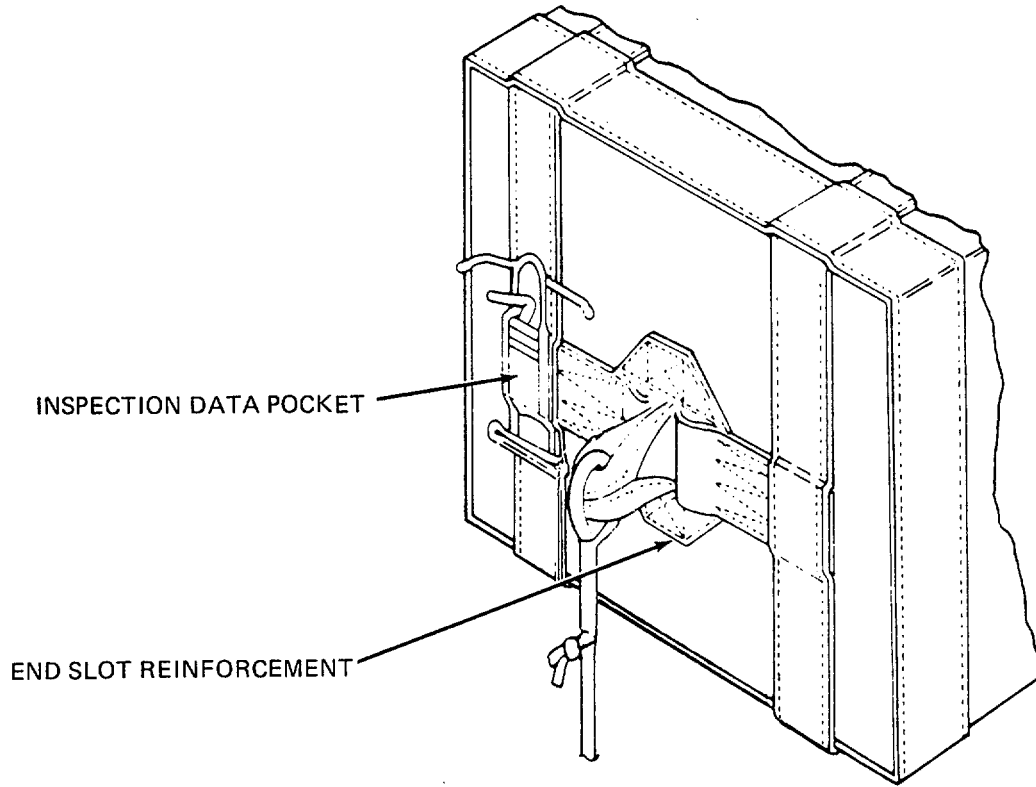

4728-070A

*Figure 2-61. Attaching Parachute Inspection Data Pocket.*

---

**2-40. Deployment Bag Retainer Band Keeper Reinforcement.**

---

This task covers:      a. Repair      b. Replace

---

*Tools:*

Knife, Item 4, Appendix B  
Knife, Hot Metal, Item 5, Appendix B  
Sewing Machine, Medium Duty, Item 19,  
Appendix B  
Shears, Item 14, Appendix B  
Yardstick, Item 24, Appendix B

*Materials/Parts:*

Thread, Nylon, Size FF, Item 28/29,  
Appendix D  
Webbing, Nylon, Type VIII, Item 37,  
Appendix D

*Personnel Required:*

43E(10) Parachute Rigger

*Equipment Condition:*

Cleaned, paragraph 2-12  
Inspected, paragraphs 2-9, 2-13  
Laid out on work table

*Reference:*

Group No. 02, MAC, Section II,  
Appendix B

---

a. Repair. Stitch and restitch with size FF thread which matches the color of the original stitching, when possible. Lock all straight stitching by backstitching at least 1/2 inch. Restitch by overstitching each end of the stitch formation by 1/2 inch. Restitch directly over the original stitching, following the original stitch pattern as closely as possible. Stitch according to para. 2-18 and table 2-3.

b. Replace. Replace a damaged retainer band keeper reinforcement by fabricating as follows (figure 2-62):

- (1) Remove portion of retainer band keeper that is secured to inside of suspension line stowage flap by cutting applicable stitching.
- (2) Turn flap to locate flap outside facing up. Cut stitching securing edge binding tape over end of applicable damaged reinforcement. Cut stitching to a point 2 inches beyond each edge of reinforcement.
- (3) Cut an 18-inch length of 1 23/32-inch wide, type VIII nylon webbing and sear ends in accordance with para. 2-19.
- (4) Position webbing length over damaged reinforcement on outside of suspension line stowage flap. Ensure one webbing end is aligned with original reinforcement end at outer edge of suspension line stowage panel.
- (5) Fold loose edge binding back. Secure webbing length over original reinforcement by stitching a box-stitch formation, 1/8 inch in from each edge, full length of webbing, using a medium-duty sewing machine and size FF nylon thread. Stitching will be 7 to 11 stitches per inch.

- (6) Reposition flap edge binding in original location and restitch, using a medium-duty sewing machine and size FF nylon thread. Stitching will be 7 to 11 stitches per inch.
- (7) Turn flap to locate flap inside facing up and reposition retainer band keeper in original location. Secure keeper by stitching a single x-box stitch formation with one double end, using a medium-duty sewing machine and size FF nylon thread. Stitching will be 7 to 11 stitches per inch.

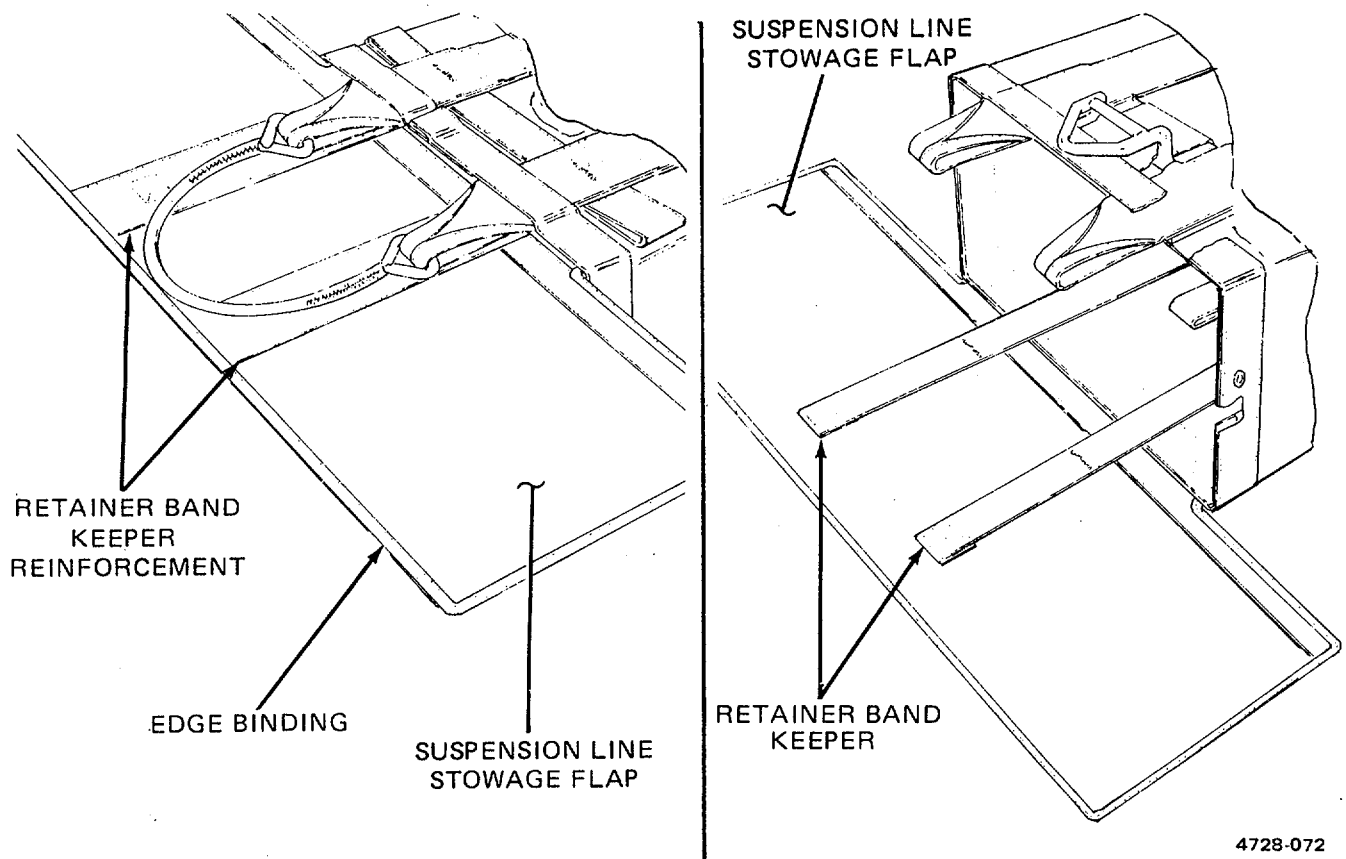

4728-072

Figure 2-62. Retainer Band Keeper Reinforcement Replacement Details.

---

## 2-41. Deployment Bag Tie Loop and Tie Loop Reinforcement.

---

This task covers:      a. Repair      b. Replace

---

*Tools:*

Knife, Item 4, Appendix B  
Knife, Hot Metal, Item 5, Appendix B  
Sewing Machine, Medium Duty, Item 19,  
Appendix B  
Shears, Item 14, Appendix B  
Yardstick, Item 24, Appendix B

*Materials/Parts:*

Thread, Nylon, Size FF, Item 28129,  
Appendix D  
Webbing, Nylon, Type IV, 1-Inch,  
Item 36, Appendix D  
Webbing, Nylon, Type IV, 1-112-Inch,  
Item 38, Appendix D

*Personnel Required:*

43E(10) Parachute Rigger

*Equipment Condition:*

Cleaned, paragraph 2-12  
Inspected, paragraphs 2-9, 2-13  
Laid out on work table

*Reference:*

Group No. 02, MAC, Section II,  
Appendix B

---

a. *Repair.* Stitch and restitch with size FF thread which matches the color of the original stitching, when possible. Lock all straight stitching by backstitching at least 1/2 inch. Restitch by over stitching each end of the stitch formation by 1/2 inch. Restitch directly over the original stitching, following the original stitch pattern as closely as possible. Stitch according to para. 2-18 and table 2-3.

b. *Replace.* When either a tie loop on bag inside or a tie loop reinforcement on bag outside is damaged, the replacement action will include both items. Replace a tie loop and tie loop reinforcement by fabricating as follows (figure 2-63):

- (1) Remove applicable original tie loop and tie loop reinforcement by cutting stitching that secures both items to deployment bag.
- (2) Cut a 10-inch length of 1-inch wide, type IV nylon webbing and a 3-inch length of 1 1/2-inch wide, type IV nylon webbing. Sear ends of both webbing lengths according to para. 2-19.
- (3) Make a 1/2-inch long turnunder on each end of 3-inch webbing length and position folded webbing in original tie loop reinforcement location on deployment bag outside with turnunder ends facing down. Secure replacement reinforcement to deployment bag outside by making a single row of stitching, 1/8 inch in, along each outside edge (A, figure 2-63), using a medium-duty sewing machine and size FF nylon thread. Stitching will be 7 to 11 stitches per inch.

- (4) Double 10-inch webbing length, align ends, and position folded webbing in original tie loop location on inside of deployment bag. Secure replacement tie loop to deployment bag and tie loop reinforcement by stitching a 3/4-inch wide by 1-inch long single-X-box-stitch formation with one double end (B, figure 2-63), using a medium-duty sewing machine and size FF nylon thread. Stitching will be 7 to 11 stitches per inch.

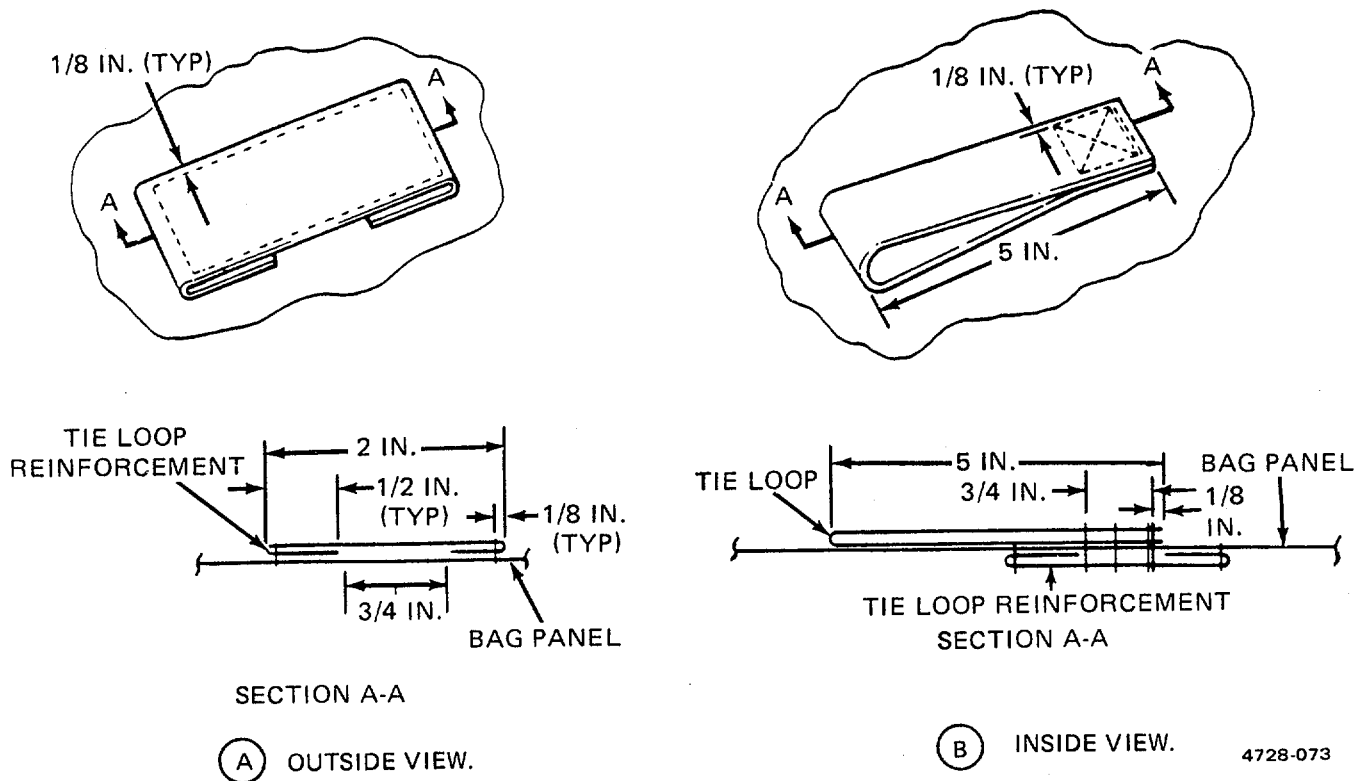

Figure 2-63. Tie Loop and Tie Loop Reinforcement Replacement.

---

**2-42. Deployment Bag Safety Cord.**

---

This task covers:      a. Repair      b. Replace

---

*Tools:*

Knife, Item 4, Appendix B  
Sewing Machine, Zig-Zag, Item 17,  
Appendix B  
Shears, Item 14, Appendix B  
Splicing Aid, Item 25, Appendix B  
Yardstick, Item 24, Appendix B

*Materials/Parts:*

Cord, Nylon, Type IV, Item 7, Appendix D  
Marking Aid, Item 15116, Appendix D  
Thread, Nylon, Size E, Item 26/27,  
Appendix D

*Personnel Required:*

43E(10) Parachute Rigger

*Equipment Condition:*

Cleaned, paragraph 2-12  
Inspected, paragraphs 2-9, 2-13  
Laid out on work table

*Reference:*

Group No. 02, MAC, Section II,  
Appendix B

---

a. Repair. Stitch and restitch with size FF thread which matches the color of the original stitching, when possible. Lock all straight stitching by backstitching at least 1/2 inch. Restitch by overstitching each end of the stitch formation by 1/2 inch. Restitch directly over the original stitching, following the original stitch pattern as closely as possible. Stitch according to para. 2-18 and table 2-3.

b. Replace. Replace a damaged safety cord by fabricating as follows:

- (1) Remove original safety cord from bottom bag closing loops by cutting cord end loops.
- (2) Cut a 25 1/2-inch length of type IV coreless nylon cord and taper-cut each end by 1/2 inch.
- (3) Using marking aid, mark the cord length at points 3, 5, and 8 inches from one tapered end (figure 2-64).

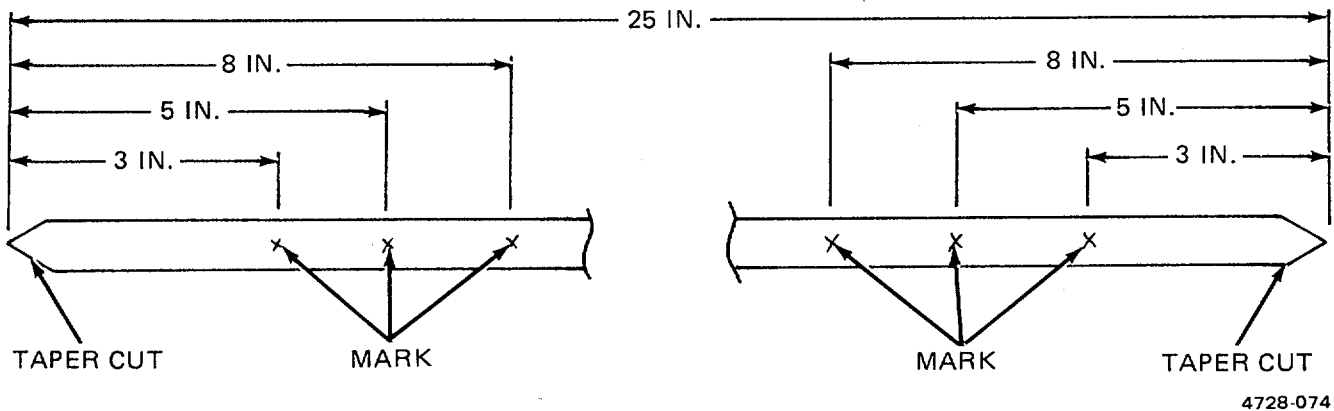
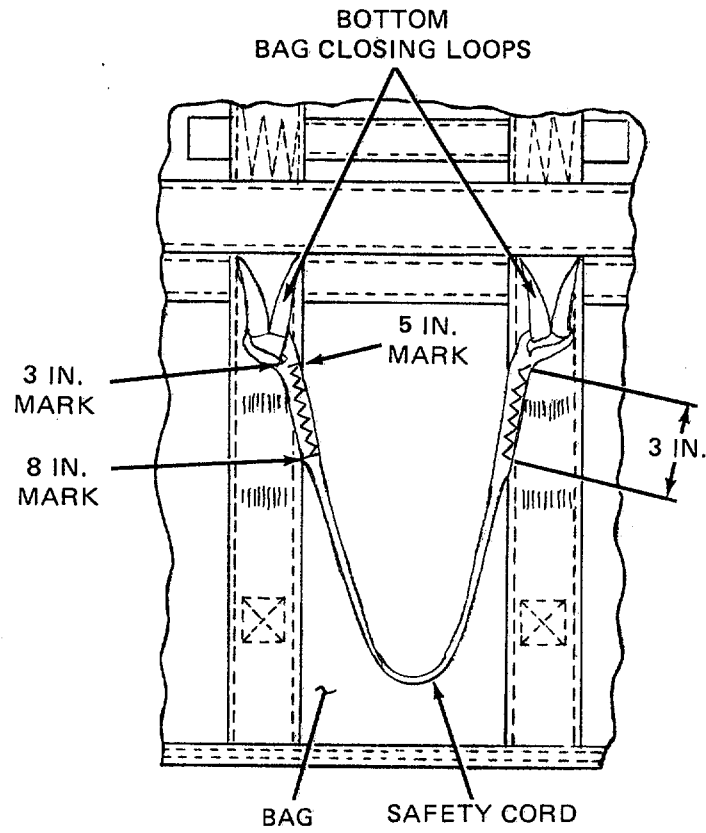

Figure 2-64. Safety Cord Fabrication Details.

- (4) Insert splicing aid into cord casing at 8-inch mark and work aid through cord to outside at 5-inch mark (figure 2-65).
- (5) Pass 4 inches of marked cord end through one bottom bag closing loop and attach tapered end to splicing aid.
- (6) Pull splicing aid with attached cord end back into cord casing at 5-inch mark and work aid back through cord casing until 3- and 5-inch marks are alined.
- (7) Hold alined marks together and work splicing aid and tapered cord end to outside at 8-inch mark.
- (8) Remove tapered cord end from splicing aid and while holding alined 3- and 5-inch marks together, stretch cord length to allow tapered cord end to recede inside cord casing.
- (9) Secure formed safety cord end loop by stitching a 3/16-inch wide by 3-inch long row using a zig-zag sewing machine and size E nylon thread. Stitching will be 7 to 11 stitches per inch.
- (10) Mark and attach cord running end to opposite bottom bag closing loop using procedures in (3) through (9) above.

2-42. Deployment Bag Safety Cord. (cont).



4728-075

Figure 2-65. Safety Cord Replacement Details.



**2-43. Deployment Bag Stowage Flap Edge Binding.**

---

This task covers: a. Repair

---

*Tools:*

Knife, Item 4, Appendix B  
Sewing Machine, Medium Duty, Item 19,  
Appendix B  
Shears, Item 14, Appendix B  
Yardstick, Item 24, Appendix B

*Materials/Parts:*

Thread, Nylon, Size FF, Item 28129,  
Appendix D  
Tape, Nylon, 3/4-inch Wide, Type III,  
Item 21, Appendix D

*Personnel Required:*

43E(10) Parachute Rigger

*Equipment Condition:*

Cleaned, paragraph 2-12  
Inspected, paragraphs 2-9, 2-13  
Laid out on work table

*Reference:*

Group No. 02, MAC, Section II,  
Appendix B

---

a. Stitching. Stitch and restitch with size FF thread which matches the color of the original stitching, when possible. Lock all straight stitching by backstitching at least 1/2 inch. Restitch by overstitching each end of the stitch formation by 1/2 inch. Restitch directly over the original stitching, following the original stitch pattern as closely as possible. Stitch according to para. 2-18 and table 2-3.

b. Splicing. Splice an edge binding an unlimited number of times as follows (figure 2-66):

- (1) Cut a length of 3/4-inch wide type III nylon tape 2 inches longer than damaged area.
- (2) Make a 1/2-inch foldunder on each end of tape length.
- (3) Center and fold tape lengthwise over edge of the damaged area. Secure splice by stitching a boxstitch formation, 1/16 inch in from each edge, along full length of splice material, using a medium-duty sewing machine and size FF nylon thread. Stitching will be 7 to 11 stitches per inch.

2-43. Deployment Bag Stowage Flap Edge Binding (cont).

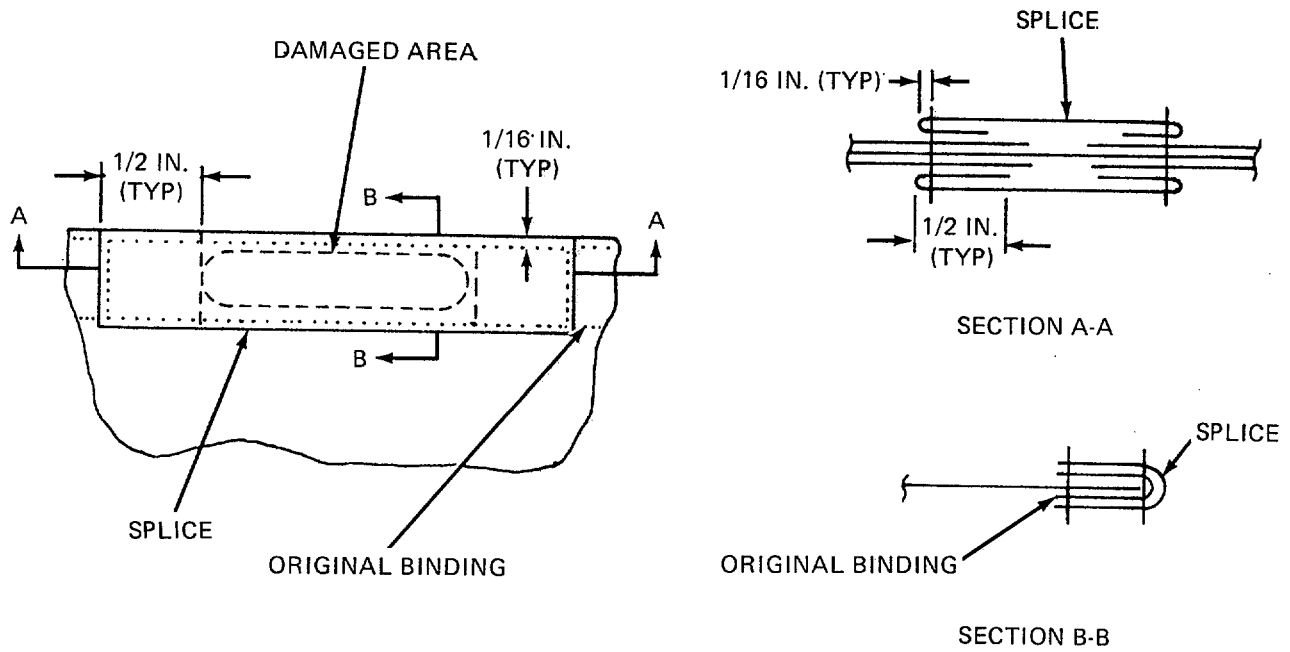

4728-080

Figure 2-66. Edge Binding Splicing Detail.

---

## 2-44. Deployment Bag Stowage Flap Edge Reinforcement.

---

This task covers: a. Repair

---

*Tools:*

Knife, Item 4, Appendix B  
Sewing Machine, Medium Duty, Item 19,  
Appendix B  
Shears, Item 14, Appendix B  
Yardstick, Item 24, Appendix B

*Materials/Parts:*

Thread, Nylon, Size FF, Item 28129,  
Appendix D  
Webbing, Nylon, 1-inch Wide, Type IV,  
Item 36, Appendix D

*Personnel Required:*

43E(10) Parachute Rigger

*Equipment Condition:*

Cleaned, paragraph 2-12  
Inspected, paragraphs 2-9, 2-13  
Laid out on work table

*Reference:*

Group No. 02, MAC, Section II,  
Appendix B

---

a. ***Stitching.*** Stitch and restitch with size FF thread which matches the color of the original stitching, when possible. Lock all straight stitching by backstitching at least 1/2 inch. Restitch by overstitching each end of the stitch formation by 1/2 inch. Restitch directly over the original stitching, following the original stitch pattern as closely as possible. Stitch according to para. 2-18 and table 2-3.

b. ***Splicing.*** A stowage flap edge reinforcement may be spliced an unlimited number of times as follows (figure 2-67):

- (1) Cut a length of 1-inch wide, type IV nylon webbing long enough to extend 2 3/4 inches beyond each side of damaged area and sear ends according to para. 2-19.
- (2) Center webbing length lengthwise over damaged area including edge binding, and secure the splice by stitching a box-stitch formation, 1/8 inch in from each edge, along full length of splice material, using a medium-duty sewing machine and size FF nylon thread. Stitching will be 7 to 11 stitches per inch.

2-44. Deployment Bag Stowage Flap Edge Reinforcement (cont).

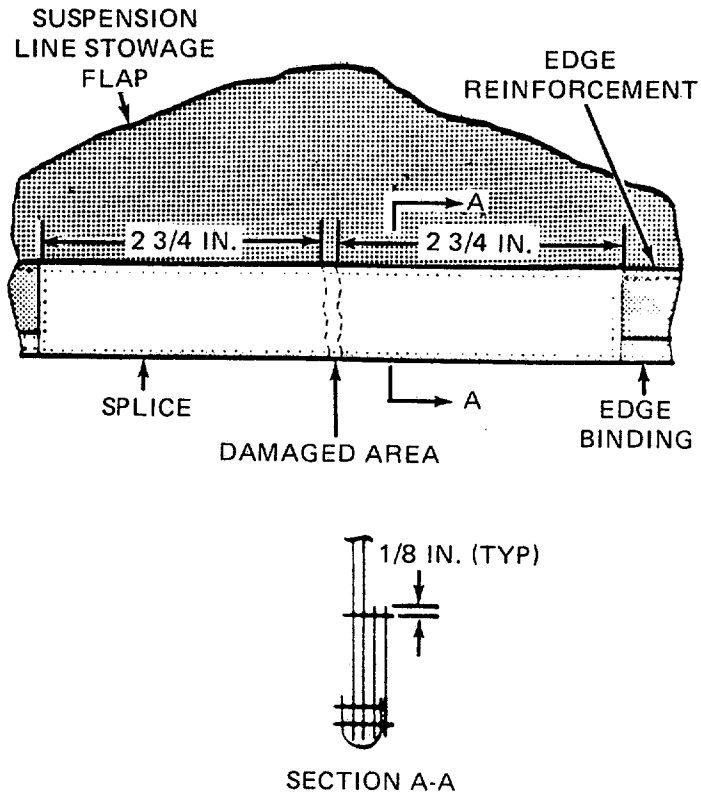

4728-079

Figure 2-67. Stowage Flap Edge Reinforcement Details.

## 2-45. Deployment Bag Main Strap.

---

This task covers:        Repair

---

*Tools:*

Sewing Machine, Medium Duty, Item 19,  
Appendix B

*Material/Parts:*

Thread, Nylon, Size FF, Item 28129,  
Appendix D  
Webbing, Nylon, Type VIII, Item 37,  
Appendix D

*Personnel Required:*

43E(10) Parachute Rigger

---

*Equipment Condition:*

Cleaned, paragraph 2-12  
Inspected, paragraphs 2-9, 2-13  
Laid out on work table

*Reference:*

Group No. 02, MAC, Section II,  
Appendix B

Stitch and restitch with size FF thread which matches the color of the original stitching, when possible. Lock all straight stitching by backstitching at least 1/2 inch. Restitch by overstitching each end of the stitch formation by 1/2 inch. Restitch directly over the original stitching, following the original stitch pattern as closely as possible. Stitch according to para. 2-19 and table 2-3.

---

## 2-46. Deployment Bag Panels and Flaps.

---

This task covers:        Repair

---

*Tools:*

Push Pins  
Shears, Item 14, Appendix B  
Sewing Machine, Darning, Item 20,  
Appendix B  
Sewing Machine, Light Duty, Item 16,  
Appendix B

*Materials/Parts:*

Marking Aid, Item 15/16, Appendix D  
Thread, Nylon, Size E, Item 26127,  
Appendix D  
Cloth, Nylon Duck, 7.25 Oz., Item 4,  
Appendix D

*Personnel Required:*

43E(10) Parachute Rigger

*Equipment Condition:*

Cleaned, paragraph 2-12  
Inspected, paragraphs 2-9, 2-13  
Laid out on work table

*Reference:*

Group No. 02, MAC, Section II,  
Appendix B

---

(a) *Stitching.* Stitch and restitch with thread which matches the color of the original stitching, when possible. Lock all straight stitching by backstitching at least 1/2 inch. Restitch by overstitching each end of the stitch formation by 1/2 inch. Restitch directly over the original stitching, following the original stitch pattern as closely as possible, in accordance with para. 2-18b.

(b) *Darning.* Darn a hole or tear which does not exceed 3/4 inch in length or diameter according to procedures in para. 2-18c, using a darning machine with size E nylon thread. There is no limit to the number of darns which may be made on the bag panels and flaps.

(c) *Patching.* Patch a hole or tear which exceeds 3/4 inch in length or diameter using 7.25-ounce nylon duck cloth and specifics in table 2-3. There is no limit to the number of patches which may be made on the bag panels and flaps proceed as follows:

### NOTE

Patches may be applied to the inside or outside of deployment bag. The damaged area must be accessible and there must be at least 1 1/4 inches of undamaged material remaining on all sides of the affected area.

- (1) Smooth fabric around the damaged area, and secure with pushpins. Do not pin damaged area.
- (2) Using a marking aid of contrasting color, mark a square or rectangle around the area to be patched and ensure one side of marked square or rectangle is parallel to warp or filling of fabric.

- (3) Cut damaged area fabric along lines made in (b) above. Further cut fabric diagonally at each corner to allow a 1/2-inch foldback in raw edges.
  - (4) Make a 1/2-inch foldback on each raw edge. Pin and baste each foldback to complete prepared hole. Basting will be performed using procedures in para. 2-18a.
  - (5) Using nylon cloth, mark and cut a patch 2 1/2 inches wider and longer than inside measurements of the prepared hole. Ensure that patch material is marked and cut along the warp or filling of fabric.
  - (6) Center patch material over prepared hole. Pin patch material in position.
  - (7) Make a 1/2-inch foldunder on each edge of patch material and baste patch to prepared area. Basting will be performed using procedures in para. 2-18a.
  - (8) Remove pushpins securing the item to repair table and secure the patch by stitching, using a light-duty sewing machine and size E nylon thread. Stitching will be 7 to 11 stitches per inch (figure 2-68). Make first row of stitching completely around patch. Turn deployment bag inside out and make a second row of stitching around prepared hole.
- d. Restenciling. As required, restencil identification markings using procedures in para. 2-20.

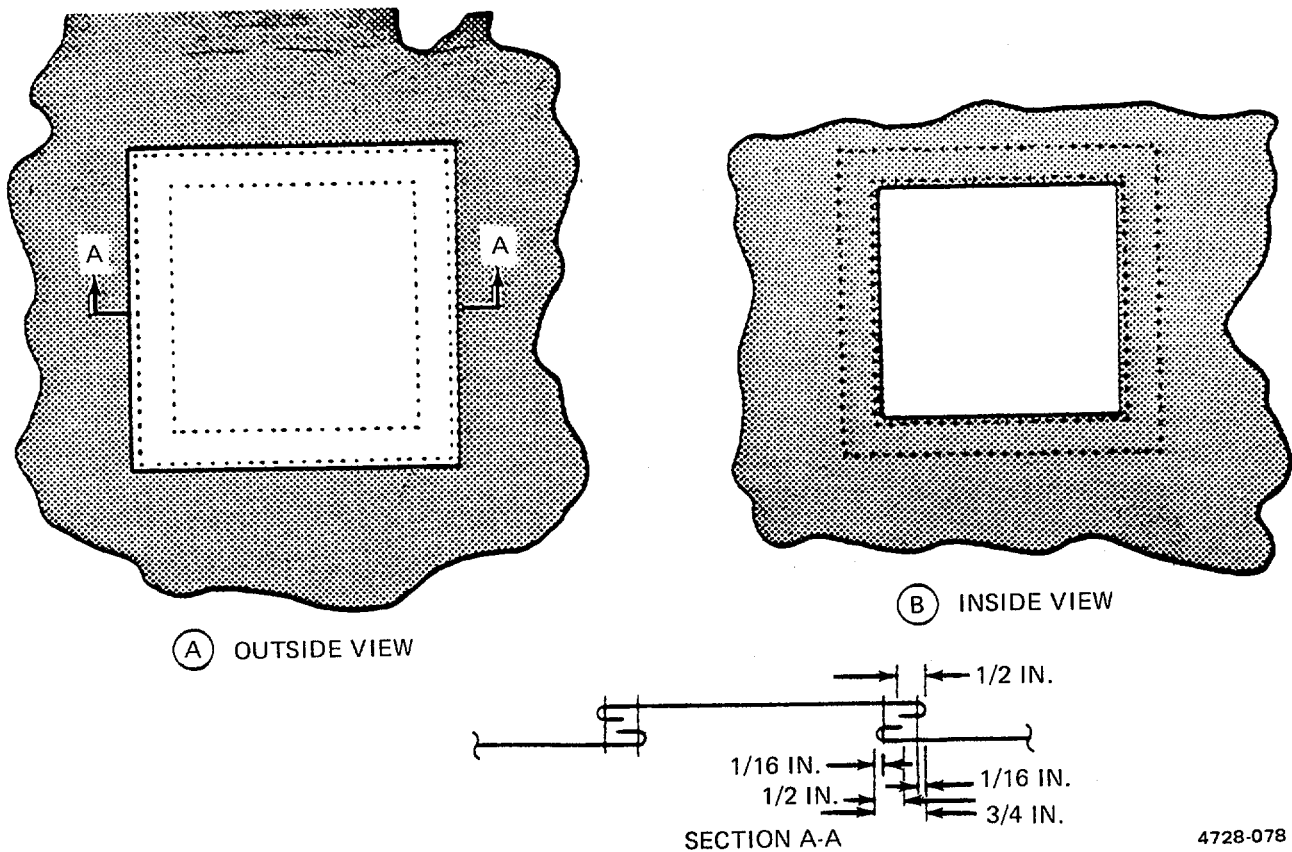

Figure 2-68. Patching Deployment Bag Panels and Flaps.

## 2-47. Deployment Bag Pendulum Line.

---

This task covers:        Replace

---

*Tools:*

Knife, Item 4, Appendix B  
Knife, Hot Metal, Item 5, Appendix B  
Shears, Item 14, Appendix B  
Splicing Aid, Item 25, Appendix B

*Materials/Parts:*

Marking Aid, Item 15/16, Appendix D  
Cord, Nylon, Type IV, Item 7, Appendix D

*Personnel Required:*

43E(10) Parachute Rigger

---

*Equipment Condition:*

Cleaned, paragraph 2-12  
Inspected, paragraphs 2-9, 2-13  
Laid out on work table

*Reference:*

Group No. 02, MAC, Section II,  
Appendix B

A pendulum line which is damaged or does not conform to the length criteria prescribed in this paragraph will be replaced by fabricating as follows:

- a. Remove original pendulum line by cutting loop formed in line at the deployment bag pendulum line attaching loop.

**CAUTION**

Do not cut or break the threads in the type IV coreless nylon cord casing while fabricating a pendulum line.

- b. Cut an 85-inch length of type IV coreless nylon cord. Taper-cut 1/2 inch of one cord end, sear opposite cord end in accordance with para. 2-19.
- c. Using a marking aid, mark cord length at points 6 1/2 and 8 inches from cord tapered end (figure 2-69).
- d. Insert splicing aid into cord casing at 8-inch mark and work aid through cord to outside at 6 1/2-inch mark.



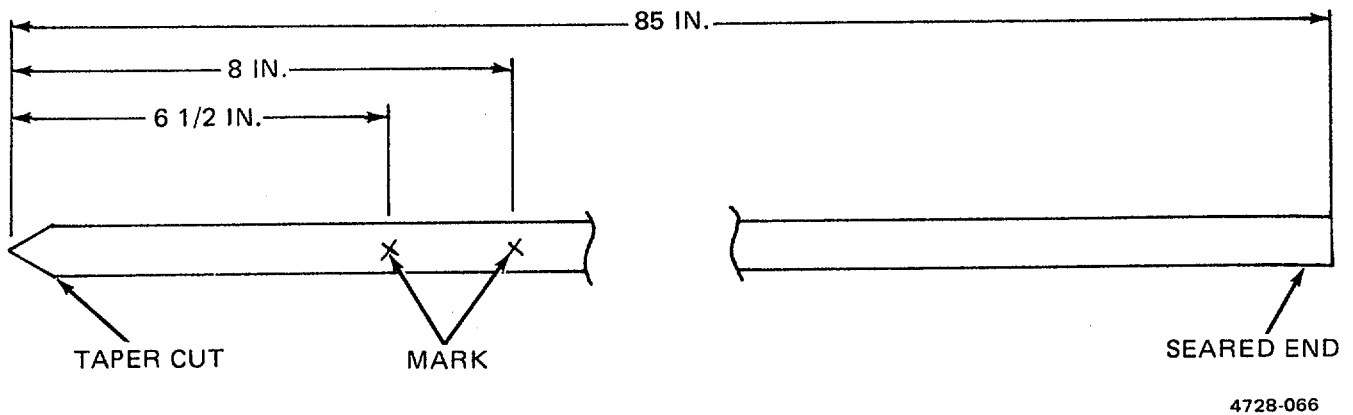
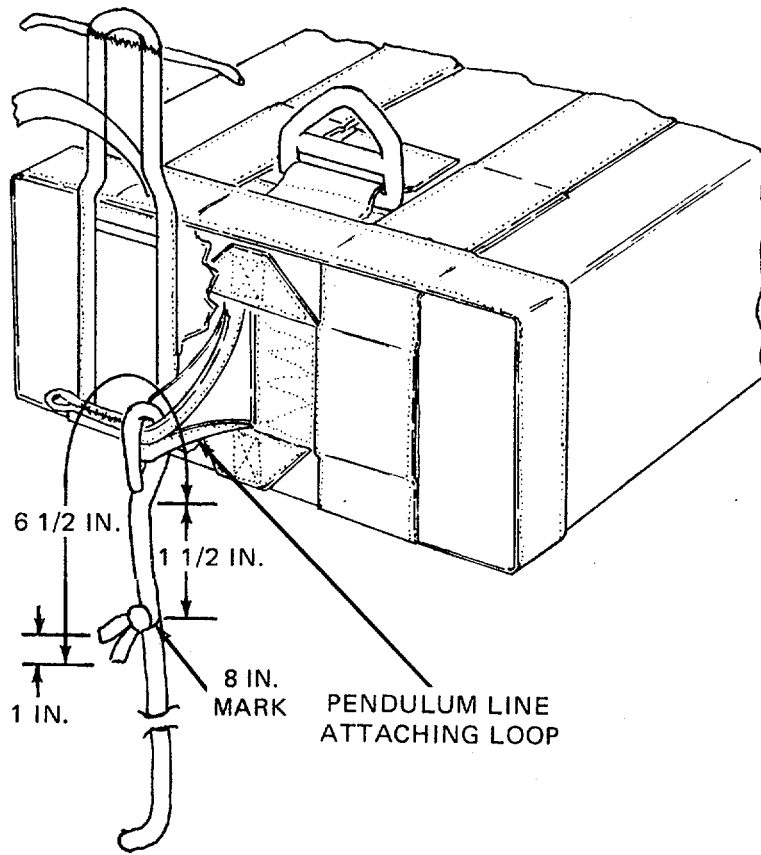

Figure 2-69. Replacement Pendulum Line Construction Details.

- e. Pass tapered cord end through deployment bag pendulum line attaching loop and attach tapered end to splicing aid.
- f. Pull splicing aid back into cord casing at 6 1/2-inch mark and work aid back through cord casing to outside at 8-inch mark (figure 2-70).
- g. Remove tapered cord end from splicing aid. Sear tapered end and make an overhand knot in cord running end at a point 1 inch back from seared tapered end. Stretch cord loop to draw knot against cord casing.

2-47. Deployment Bag Pendulum Line (cont).



4728-067

Figure 2-70. Pendulum Line Replacement Details.

---

## 2-48. 5-Foot Long Adapter Web.

---

This task covers:      a. Inspect      b. Service      c. Repair      d. Replace

---

*Personnel Required:*

43E(10) Parachute Rigger

*Reference:*

Group No. 03, MAC, Section II  
Appendix B

*Equipment Condition:*

Cleaned, paragraph 2-12  
Inspected, paragraphs 2-9, 2-13  
Laid out on work table

---

### NOTE

When a 60-foot, type X, 6-ply extraction line is damaged beyond repair or a type XXVI extraction line is required, the type XXVI 5-foot long adapter web will be installed on the 22-foot extraction parachute. The complete parachute assembly will then consist of a deployment bag, the canopy, and the adapter web (type XXVI). At this time the assembly will be reidentified to NSN 1670-01-063-3716 with a part number of 11-1-2584. The type X, 60-foot extraction line, type X adapter web and type IV link will then no longer be components of the 22-foot extraction parachute. The NSN for the type XXVI 5-foot long adapter web is 1670-01-063-3691. The type X extraction line will not be used with the type XXVI adapter web.

- a. Inspect. Inspect adapter web in accordance with paras. 2-9 and 2-13.
- b. Service. Service adapter web by cleaning in accordance with para. 2-12.

### CAUTION

When performing a repair on the 5-foot long adapter web which requires the cutting of stitching or tacking, ensure that adjacent webbing material is not damaged during the cutting process.

- c. Repair. Refer to individual component procedures for repair of adapter web.
- d. Replace. Replace an unserviceable/unrepairable adapter web with a serviceable one from stock.

**2-49. 5-Foot Long Adapter Web Body.**

---

This task covers:       Repair

---

***Tools:***

Sewing Machine, Medium Duty, Item 19,  
Appendix B

***Materials/Parts:***

Thread, Nylon, Size 6, Item 31, Appendix D

***Personnel Required:***

43E(10) Parachute Rigger

---

***Equipment Condition:***

Inspected, paragraph 2-12  
Cleaned, paragraphs 2-9, 2-13  
Adapter laid out on table

***Reference:***

Group 03, MAC, Section II,  
Appendix B

a. ***Stitching.*** Stitch and restitch with size 6 nylon thread which matches the color of the original stitching, when possible. Lock all straight stitching by backstitching at least 1/2 inch. Restitch by over stitching each end of the stitch formation by 1/2 inch. Restitch directly over the original stitching, following the original stitch pattern as closely as possible. Stitch 5-8 stitches per inch according to para. 2-18 and table 2-3.

b. ***Restencil.*** As required, restencil identification marks using procedures in para. 2-20.

---

## 2-50. 5-Foot Long Adapter Web Long Buffer.

---

This task covers:      a. Repair      b. Replace

---

*Tools:*

Pot, Melting, Item 13, Appendix B  
Knife, Item 4, Appendix B

Yardstick, Item 25, Appendix B

*Materials/Parts:*

Thread, Waxed, Cotton, Ticket 8/7,  
Item 25, Appendix D  
Webbing, Cotton, Type X, Item 35,  
Appendix D  
Webbing, Nylon, Type VII,  
Item 40, Appendix D

*Personnel Required:*

43E(10) Parachute Rigger

*Equipment Condition:*

Cleaned, paragraph 2-12  
Inspected, paragraphs 2-9, 2-13  
Laid out on work table

*Reference:*

Group No. 03, MAC, Section II, Appendix B

---

*a. Repair.* Replace broken or loose tacking securing the long buffer in the 6 1/8-inch long single attaching loop by retacking according to original tacking details using one turn double, ticket 8/7 waxed cotton thread at each tacking point. Secure the tacking with a square knot and locking knot and trim ends to 1/2-inch.

*b. Replace.* Replace a damaged or missing long buffer in a 6 1/8-inch long single attaching loop by fabricating as follows (figure 2-71):

- (1) Remove original buffer from single attaching loop by cutting tacking securing buffer within loop.
- (2) Cut a 12 1/2-inch length of 1 3/4-inch wide, type X cotton webbing and wax ends or type VII nylon webbing and sear ends.
- (3) Double webbing length, aline ends, and install doubled webbing in original buffer location within single attaching loop.
- (4) Secure folded webbing to attaching loop webbing by handtacking at three points using one turn double, ticket 8/7 waxed cotton thread at each point. Secure tacking ends at each tacking point with a surgeon's knot and locking knot on loop outside. Trim tie ends to 1/2 inch.

2-50. 5-Foot Long Adapter Web Long Buffer (cont).

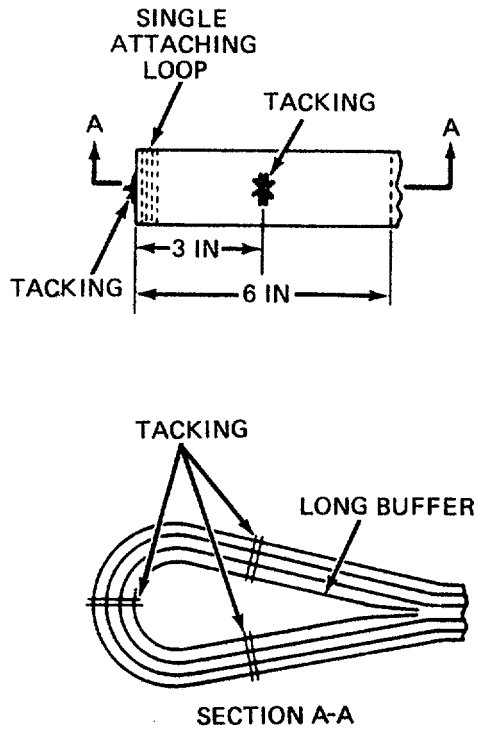

4728-082

Figure 2-71. Long Buffer Replacement Details.

## 2-51. Extraction Line (60-Foot Long).

---

This task covers:      a. Inspect      b. Service      c. Replace

---

*Personnel Required:*

43E(10) Parachute Rigger

*Equipment Condition:*

Cleaned, paragraph 2-12  
Laid out on work table

---

*Reference:*

Group No. 04, MAC, Section II,  
Appendix B

- a. Inspect. Inspect a 60-foot long extraction line according to paras. 2-9 and 2-13.
- b. Service. Clean a 60-foot long extraction line according to para. 2-12.
- c. Replace.

### NOTE

When a 60-foot, Type X, 6-ply extraction line is damaged beyond repair or a type XXVI extraction line is required, the type XXVI 5-foot long adapter web will be installed on the 22-foot extraction parachute. The complete parachute assembly will then consist of a deployment bag, the canopy, and the adapter web (type XXVI). At this time, the assembly will be reidentified to NSN 1670-01-063-3716 with a part number of 11-1-2584. The type X, 60-foot extraction line, Type X adapter web and Type IV link will then no longer be components of the 22-foot extraction parachute. The NSN for the type XXVI 5-foot long adapter web is 1670-01-063-3691. The Type X extraction line will not be used with the Type XXVI adapter web.

---

## 2-52. Type IV Quick Release Link Assembly.

---

This task covers:      a. Inspect      b. Service      c. Repair      d. Replace

---

*Tools:*

File, Item 3, Appendix B

*Personnel Required:*

43E(10) Parachute Rigger

*Materials/Parts:*

Cloth, Abrasive, Item 3, Appendix D

*Reference:*

Group No. 04, MAC, Section II, Appendix B

---

### NOTE

When a 60-foot, type X, 6-ply extraction line is damaged beyond repair or type XXVI extraction line is required, the type XXVI 5-foot long adapter web will be installed on the 22-foot extraction parachute. The complete parachute assembly will then consist of a deployment bag, the canopy, and the adapter web (type XXVI). At this time the assembly will be reidentified to NSN 1670-01-063-3716 with a part number of 11-1-2584. The type X, 60-foot extraction line, type X adapter web and type IV link will then no longer be components of the 22-foot extraction parachute. The NSN for the type XXVI 5-foot long adapter web is 1670-01-063-3691. The type X extraction line will not be used with the type XXVI adapter web.

- a. Inspect.** Inspect quick release link assembly in accordance with paras. 2-9 and 2-13.
- b. Service.** Service quick release link assembly by cleaning in accordance with para. 2-12.
- c. Repair.** (Figure 2-72).
- (1) Depress button, slide side link cover lock forward. Remove side link plate from sleeve pins.
  - (2) Remove sleeves from sleeve pins.
  - (3) Remove rough spots, burrs, and rust with abrasive cloth or a metal file.
  - (4) Use abrasive cloth to smooth sliding surface of link plate and sleeve pins.
  - (5) Install sleeves on sleeve pins.
  - (6) Install side link plate on sleeve pins.
  - (7) Depress button and slide side link cover lock into locked position. Release button.
- d. Replace.** Replace an unserviceable quick release link assembly with a serviceable item from stock.



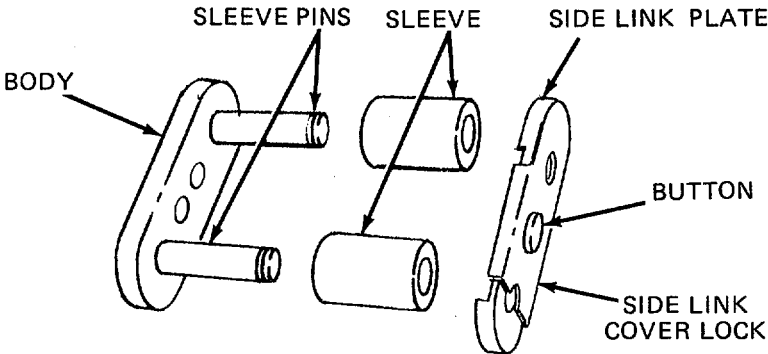

4728-081

Figure 2-72. Type IV Quick Release Link Assembly Repair.

**Section VII. PREPARATION FOR STORAGE OR SHIPMENT**

Paragraph		Page
2-53	Storage.....	2-132
2-54	In-Storage Inspection.....	2-133
2-55	Shipment.....	2-133

## 2-53. Storage.

a. Storage Criteria. Administrative storage of air delivery equipment will be accomplished in accordance with AR 750-1 and the instructions furnished below.

b. General Storage Requirements. To insure that serviceability standards of stored air delivery equipment are maintained, every effort will be exerted to adhere to the following storage requirements:

- (1) When available, a heated building should be used to store parachutes and other air delivery items.
- (2) Air delivery equipment will be stored in a dry, well-ventilated location and protected from pilferage, dampness, fire, dirt, insects, rodents, and direct sunlight.
- (3) Air delivery equipment will not be stored in a manner which would prevent ventilation or interfere with light fixtures, heating vents, fire fighting devices, cooling units, exits, or fire doors.
- (4) Air delivery items will not be stored in a damaged, dirty, or damp condition.
- (5) All stored air delivery items will be marked, segregated, and located for accessibility and easy identification.
- (6) Air delivery equipment will not be stored in direct contact with any building floor or wall. Storage will be accomplished using bins, shelves, pallets, racks, or dunnage to provide airspace between the storage area floor and the equipment. If preconstructed shelving or similar storage accommodations are not available, locally fabricate storage provisions using suitable lumber or wooden boxes.
- (7) All available materials handling equipment should be used as much as possible in the handling of air delivery items.
- (8) Periodic rotation of stock, conversion of available space, proper housekeeping policies, and strict adherence to all safety regulations will be practiced at all times.

c. Storage Specifics for Parachutes. In addition to the storage requirements stipulated in subparagraph b. above, the following is a list of specifics which must be enforced when storing parachutes:

- (1) Except for those assemblies required for contingency operation, parachutes will not be stored in a packed configuration.
- (2) Stored parachute assemblies will be secured from access by unauthorized personnel.
- (3) A parachute which is in storage, and is administered a cyclic repack and inspection, will not be exposed to incandescent light or indirect sunlight for a period of more than 36 hours. In addition, exposure to direct sunlight should be avoided entirely.

## 2-54. In-Storage Inspection.

a. General Information. An in-storage inspection is a physical check conducted on a random sample of air delivery equipment which is located in storage.

b. Intervals. Parachutes in storage will be inspected at least semiannually and at more frequent intervals if prescribed by the local parachute maintenance officer.

c. Inspection. Inspect to insure that the parachute is ready for issue.

- (1) Check the parachute for proper identification.
- (2) Check that no damage or deterioration has been incurred.
- (3) Ensure that all modifications or similar requirements have been completed.
- (4) Check the adequacy of the storage facilities; efforts taken to control pests and rodents; and protection against unfavorable climatic conditions.

## 2-55. Shipment.

a. Initial Shipment. The initial packaging and shipping of air delivery equipment is the responsibility of item manufacturers who are required to comply with federal and military packaging specifications as stipulated in contractual agreements. Air delivery equipment is normally shipped to depot activities by domestic freight or parcel post, packaged to comply with overseas shipping requirements. Except for those air delivery items which are unpackaged and subjected to random inspections or testing by a depot activity, air delivery equipment received by a using unit will be contained in original packaging materials.

b. Shipping Between Maintenance Activities. The shipping of air delivery equipment between organizational and direct support maintenance activities will be accomplished on a signature verification basis using whatever means of transportation are available. Used parachutes and other fabric items will be tagged in accordance with DA PAM 738-751, and rolled, folded, or placed loosely in a parachute pack, deployment bag, or other suitable container, as required. Used wood and metal air delivery items will be tagged as prescribed in DA PAM 738-751 and placed in a suitable type container, if necessary. Unused air delivery equipment will be transported in original shipping containers. During shipment, every effort will be made to protect air delivery items from weather elements, dust, dirt, oil, grease, and acids. Vehicles used to transport parachutes will be inspected to ensure the items are protected from the previously cited material damaging conditions.

c. Other Shipping Instructions. Air delivery equipment destined for domestic or overseas shipment will be packaged and marked in accordance with AR 700-15, TM 38-230-1, and TM 38-230-2. Shipment of air delivery items will be accomplished in accordance with AR 55-45.



**APPENDIX A**

**REFERENCES**

**A-1. Scope.** This appendix lists all forms, technical manuals, and miscellaneous publications referenced in this manual.

**A-2. Publication Indexes.** The following publication indexes should be consulted frequently for the latest changes or revisions of references given in this appendix and for new publications relating to the materia covered in this manual:

Consolidated Index of Army Publications and Blank Form .....s.....	DA PAM 25-30
The Army Maintenance Management System (TAMMS ..)	DA PAM 738-750
The Army Maintenance Management System Aviation (TAMMSA ....)	DA PAM 738-751

**A.3. Technical Manuals.**

General Maintenance of Parachutes and Other Airdrop Equipment t.....	TM 10-1670-201-23 T.O. 13C1-41/ NAVAIR 13-1-17
Miscellaneous Airdrop Canvas, Webbing, Metal, and Wood Item s.....	TM 10-1670-240-20/ T.O. 13C7-49-11
Preservation ,Packaging, Packing of Military Supplies and Equipment (Vols 1 and 2) .....	TM 38-230-1 and TM 38-230-2
Procedures for the Destruction of Air Delivery Equipment to Prevent Enemy Use.....	TM 43-0002-1

**A-4. Field Manuals.**

Airdrop of Supplies and Equipment: General Information for Rigging Airdrop Platfor m.....	FM 10-500
First Aid for Soldier .s.....	FM 21-11

**A-5. Army Regulations.**

Dictionary of United States Army Term ..s.....	AR 310-25
Authorized Abbreviation and Brevity Code ..s.....	AR 310-50
Packaging of Materia .l.....	AR 700-15
Army Materiel Maintenance Concepts and Policie ..s.....	AR 750-1
Airdrop Parachute Recovery and Aircraft Personnel Escape Systems..	AR 750-32
Reporting of Item and Packaging Discrepancie ....s.....	AR 735-11-2

**A-6. Technical Bulletins.**

Maintenance Expenditure Limits for FSC Group 1 ...6.....	TB 43-0002-4*
Use of Material Condition Tags and Labels on Army Aeronautical and Air Delivery Equipmen .t.....	TB 750-126

\*To be superceded in part by TB 43-0002-43

**A-7. Forms.**

Report of Discrepancy..... SF 364

## APPENDIX B

### MAINTENANCE ALLOCATION CHART

#### Section I. INTRODUCTION

##### B-1. The Army Maintenance System MAC

This introduction provides a general explanation of all maintenance and repair functions authorized at the two maintenance levels under the Two-Level Maintenance System concept.

The MAC (immediately following the introduction) designates overall authority and responsibility for the performance of maintenance functions on the identified end item or component. The application of the maintenance functions to the end item or component shall be consistent with the capacities and capabilities of the designated maintenance levels, which are shown on the MAC in column (4) as:

Field - includes two columns, Unit maintenance and Direct Support maintenance. The Unit maintenance column is divided again into two more subcolumns, C for Operator or Crew and O for Unit maintenance.

Sustainment – includes two subcolumns, General Support (H) and Depot (D).

The tools and test equipment requirements (immediately following the MAC) list the tools and test equipment (both special tools and common tool sets) required for each maintenance function as referenced from the MAC.

The remarks (immediately following the tools and test equipment requirements) contain supplemental instructions and explanatory notes for a particular maintenance function.

##### B-2. Maintenance Functions

Maintenance functions are limited to and defined as follows:

1. Inspect. To determine the serviceability of an item by comparing its physical, mechanical, and/or electrical characteristics with established standards through examination (e.g., by sight, sound, or feel.) This includes scheduled inspection and gagings and evaluation of cannon tubes.
2. Test. To verify serviceability by measuring the mechanical, pneumatic, hydraulic, or electrical characteristics of an item and comparing those characteristics with prescribed standards on a scheduled basis, i.e., load testing of lift devices and hydrostatic testing of pressure hoses.
3. Service. Operations required periodically to keep an item in proper operating condition, e.g. to clean (includes decontaminate, when required), to preserve, to drain, to paint, or to replenish fuel, lubricants, chemical fluids, or gases. This includes scheduled exercising and purging of recoil mechanisms. The following are examples of service functions:
  - a. Unpack. To remove from packing box for service or when required for the performance of maintenance operations.
  - b. Repack. To return item to packing box after service and other maintenance operations.
  - c. Clean. To rid the item of contamination.

- d. Touch up. To spot paint scratched or blistered surfaces.
  - e. Mark. To restore obliterated identification.
4. Adjust. To maintain or regulate, within prescribed limits, by bringing into proper position, or by setting the operating characteristics to specified parameters.
  5. Align. To adjust specified variable elements of an item to bring about optimum or desired performance.
  6. Calibrate. To determine and cause corrections to be made or to be adjusted on instruments of test, measuring, and diagnostic equipment used in precision measurement. Consists of comparisons of two instruments, one of which is a certified standard of known accuracy, to detect and adjust any discrepancy in the accuracy of the instrument being compared.
  7. Remove/Install. To remove and install the same item when required to perform service or other maintenance functions. Install may be the act of emplacing, seating, or fixing into position a spare, repair part, or module (component or assembly) in a manner to allow the proper functioning of an equipment or system.
  8. Paint. To prepare and spray color coats of paint so that the ammunition can be identified and protected. The color indicating primary use is applied, preferably, to the entire exterior surface as the background color of the item. Other markings are to be repainted as original so as to retain proper ammunition identification.
  9. Replace. To remove an unserviceable item and install a serviceable counterpart in its place. "Replace" is authorized by the MAC and assigned maintenance level is shown as the third position code of the Source, Maintenance and Recoverability (SMR) code.
  10. Repair. The application of maintenance services, including fault location/troubleshooting, removal/installation, disassembly/assembly procedures and maintenance actions to identify troubles and restore serviceability to an item by correcting specific damage, fault, malfunction, or failure in a part, subassembly, module (component or assembly), end item, or system.

#### NOTE

The following definitions are applicable to the "repair" maintenance function: Services, Inspect, test, service, adjust, align, calibrate, and/or replace.

Fault location/troubleshooting. The process of investigating and detecting the cause of equipment malfunctioning; the act of isolating a fault within a system or Unit Under Test (UUT).

Disassembly/assembly. The step-by-step breakdown (taking apart) of a spare/functional group coded item to the level of its least component, that is assigned an SMR code for the level of maintenance under consideration (i.e., identified as maintenance significant).

Actions. Welding, grinding, riveting, straightening, facing, machining, and/or resurfacing.

11. Overhaul. That maintenance effort (service/action) prescribed to restore an item to a completely serviceable/operational condition as required by maintenance standards in appropriate technical publications. Overhaul is normally the highest degree of maintenance performed by the Army. Overhaul does not normally return an item to like new condition.



12. Rebuild. Consists of those services/actions necessary for the restoration of unserviceable equipment to a like new condition in accordance with original manufacturing standards. Rebuild is the highest degree of material maintenance applied to Army equipment. The rebuild operation includes the act of returning to zero those age measurements (e.g., hours/miles) considered in classifying Army equipment/components.

### **B-3. Explanation of Columns in the MAC, Section II**

Column (1) Group Number. Column (1) lists Functional Group Code (FGC) numbers, the purpose of which is to identify maintenance significant components, assemblies, subassemblies, and modules with the Next Higher Assembly (NHA).

Column (2) Component/Assembly. Column (2) contains the item names of components, assemblies, subassemblies, and modules for which maintenance is authorized.

Column (3) Maintenance Function. Column (3) lists the functions to be performed on the item listed in column (2). (For a detailed explanation of these functions refer to "Maintenance Functions" outlined above).

Column (4) Maintenance Level. Column (4) specifies each level of maintenance authorized to perform each function listed in column (3), by indicating work time required (expressed as manhours in whole hours or decimals) in the appropriate subcolumn. This work time figure represents the active time required to perform that maintenance function at the indicated level of maintenance. If the number or complexity of the tasks within the listed maintenance function varies at different maintenance levels, appropriate work time figures are to be shown for each level. The work time figure represents the average time required to restore an item (assembly, subassembly, component, module, end item, or system) to a serviceable condition under typical field operating conditions. This time includes preparation time (including any necessary disassembly/assembly time), troubleshooting/fault location time, and quality assurance time in addition to the time required to perform the specific tasks identified for the maintenance functions authorized in the MAC. The symbol designations for the various maintenance levels are as follows:

#### Field:

- C Operator or Crew maintenance
- O Unit maintenance
- F Direct Support maintenance

#### Sustainment:

- L Specialized Repair Activity
- H General Support maintenance
- D Depot maintenance

### **NOTE**

The "L" maintenance level is not included in column (4) of the MAC. Functions to this level of maintenance are identified by work time figure in the "H" column of column (4), and an associated reference code is used in the REMARKS column (6). This code is keyed to the remarks and the SRA complete repair application is explained there.

Column (5) Tools and Equipment Reference Code. Column (5) specifies, by code, those common tool sets (not individual tools), common Test, Measurement and Diagnostic Equipment (TMDE), and special tools, special TMDE, and support special support equipment required to perform the designated function. Codes are keyed to the entries in the tools and test equipment table.

Column (6) Remarks Code. When applicable, this column contains a letter code, in alphabetic order, which is keyed to the remarks table entries.

**B-4. Explanation of Columns in the Tools and Test Equipment Requirements, Section III**

Column (1) – Tool or Test Equipment Reference Code. The tool or test equipment reference code correlates with a code used in column (5) of the MAC.

Column (2) – Maintenance Level. The lowest level of maintenance authorized to use the tool or test equipment.

Column (3) – Nomenclature. Name or identification of the tool or test equipment.

Column (4) – National Stock Number (NSN). The NSN of the tool or test equipment.

Column (5) – Tool Number. The manufacturer's part number.

**B-5. Explanation of Columns in Remarks, Section IV**

Column (1) – Remarks Code. The code recorded in column (6) of the MAC.

Column (2) – Remarks. This column lists information pertinent to the maintenance function being performed as indicated in the MAC.

**Section II. MAINTENANCE ALLOCATION CHART (MAC)  
 FOR  
 22 FOOT DIAMETER CARGO EXTRACTION PARACHUTE ASSEMBLY**

(1) GROUP NUMBER	(2) COMPONENT/ ASSEMBLY	(3) MAINTENANCE FUNCTION	(4) MAINTENANCE LEVEL					(5) TOOLS AND EQUIPMENT REFERENCE CODE	(6) REMARKS CODE
			FIELD		SUSTAINMENT				
			UNIT		DIRECT SUPPORT	GENERAL SUPPORT	DEPOT		
			C	O	F	H	D		
01	CANOPY	Inspect		0.7				1,5,13 4,7,10,11  4,13,14,18,24  4,5,17,24	A,B C,D E
		Service		1.0					
		Repair		0.4					
	ATTACHMENT LOOP	Repair		0.2					
		Replace		0.3					
	VENT LINE	Repair		0.3	0.5				
		Replace							
	BRIDLE CENTERING LINE	Repair		0.3					

Section II. MAINTENANCE ALLOCATION CHART (MAC)  
 FOR  
 22 FOOT DIAMETER CARGO EXTRACTION PARACHUTE ASSEMBLY - continued

(1) GROUP NUMBER	(2) COMPONENT/ ASSEMBLY	(3) MAINTENANCE FUNCTION	(4) MAINTENANCE LEVEL					(5) TOOLS AND EQUIPMENT REFERENCE CODE	(6) REMARKS CODE
			FIELD		SUSTAINMENT				
			UNIT		DIRECT SUPPORT	GENERAL SUPPORT	DEPOT		
			C	O	F	H	D		
01 - Cont.	UPPER LATERAL BAND	Repair		0.5				4,13,14,16	
	GORE SECTION	Repair Replace		0.4	0.8			4,9,14,16,20	E
	RADIAL TAPE	Repair		0.3				4,5,14,16, 17,24	
	PANEL EDGE REINFORCEMENT	Repair		0.4				4,5,14,16, 17,24	
	LOWER LATERAL BAND	Repair		0.5				4,5,14,16, 17,24	
	POCKET BAND	Repair Replace		0.3 0.4				4,5,14,16, 17,24	
	SUSPENSION LINE	Repair Replace		0.3	0.6			4,5,17,24	
	CONNECTOR LINK	Repair Replace		0.1	0.1			3,8,22,23	
02	DEPLOYMENT BAG	Inspect Service Repair Replace		0.3 0.1 0.4 0.1					A
	GROMMET	Repair Replace		0.1 0.2				3,8,12,15,19	F
	RETAINER BAND KEEPER	Repair Replace		0.2 0.4				4,5,14,19,24	
	BAG RETAINER LINE	Repair Replace		0.2 0.5				4,13,14,16 17,24,25	
	BAG CLOSING LOOP	Repair Replace		0.2 0.4				4,5,14,18,19 24	
	INSPECTION DATA POCKET	Repair Replace		0.1 0.2				17,19	

Section II. MAINTENANCE ALLOCATION CHART (MAC)  
 FOR  
 22 FOOT DIAMETER CARGO EXTRACTION PARACHUTE ASSEMBLY – continued

(1) GROUP NUMBER	(2) COMPONENT/ ASSEMBLY	(3) MAINTENANCE FUNCTION	(4) MAINTENANCE LEVEL					(5) TOOLS AND EQUIPMENT REFERENCE CODE	(6) REMARKS CODE	
			FIELD		SUSTAINMENT					
			UNIT		DIRECT SUPPORT	GENERAL SUPPORT	DEPOT			
			C	O	F	H	D			
02- Cont.	RETAINER BAND KEEPER REINFORCEMENT	Repair		0.2				4,5,14,19,24		
		Replace		0.3						
	TIE LOOP/ TIE LOOP REINFORCEMENT	Repair		0.2						4,5,14,19,24
		Replace		0.3						
	SAFETY CORD	Repair		0.2						4,14,17,24,25
		Replace		0.4						
	STOWAGE FLAP EDGE BINDING	Repair		0.3						4,14,19,24
	SUSPENSION LINE STOWAGE FLAP REINFORCEMENT	Repair		0.4						4,14,19,24
MAIN STRAP	Repair		0.2				19			
BAG PANELS	Repair		0.5				14,16,20			
PENDULUM LINE	Replace		0.3				4,5,14,25			
03	ADAPTER WEB	Inspect		0.1				4,13,19,24	A B,C	
		Service		0.1						
		Repair		0.1						
		Replace		0.1						
04	EXTRACTION LINE	Inspect		0.3				A		
		Replace		0.3						

**Section III. TOOLS AND TEST EQUIPMENT  
FOR  
22 FOOT DIAMETER CARGO EXTRACTION PARACHUTE ASSEMBLY**

(1) TOOL OR TEST EQUIPMENT REFERENCE CODE	(2) MAINTENANCE LEVEL	(3) NOMENCLATURE	(4) NATIONAL STOCK NUMBER	(5) TOOL NUMBER
1	O	Brush, Scrub, Household	7920-00-068-7903	H-B-515
2	O	Brush, Stenciling	7520-00-248-9285	H-B-621
3	O	File, Flat	5110-00-249-2848	GGG-F-325
4	O	Knife	5110-00-162-2205	MIL-K-818C
5	O	Knife, Hot Metal	3439-01-197-7656	4025
6	O	Lead, Pig, 5-pounds	9650-00-264-5050	QQ-C-40
7	O	Line Separator	1670-00-092-8661	11-1-17-1
8	O	Mallet, Rawhide	5120-00-293-3397	GGG-H-33
9	O	Needle, Tacking	8315-00-262-3733	FF-N-180
10	O	Packing Paddle	1670-00-764-6381	11-1-152
11	O	Packing Weight	1670-00-375-9134	66C38599
12	O	Pliers, Lineman	5120-00-756-1156	GGG-P-471
13	O	Pot, Melting, Electric	5120-00-242-1276	WG441
14	O	Shears	5110-00-223-6370	GGG-S-278
15	O	Set, Chuck and Die	5120-00-694-5153	7540756
16	O	Sewing Machine, Light-Duty	See Table 2-2	
17	O	Sewing Machine, Zig-Zag	See Table 2-2	
18	O	Sewing Machine, Heavy-Duty	See Table 2-2	
19	O	Sewing Machine, Medium-Duty	See Table 2-2	
20	O	Sewing Machine, Darning	See Table 2-2	
21	O	Sewing Machine, Very	See Table 2-2	
22	O	Screwdriver, Flat Tip	5120-00-293-0314	GGG-S-121
23	O	Separator, Link	1670-00-072-4941	MIL-S-43243
24	O	Yardstick	5120-00-985-6610	GGG-Y-0035
25	O	Splicing Aid	See Appendix E	

**Section IV. REMARKS  
FOR  
22 FOOT DIAMETER CARGO EXTRACTION PARACHUTE ASSEMBLY**

(1) REMARKS CODE	(2) REMARKS
A	Inspect is a technical-rigger type inspection.
B	Service is to clean equipment.
C	Service is the packing of parachutes.
D	Repair by restitching, darning or restencil canopy panel.
E	Repair at unit maintenance consists of darning, restitching, patching and replacement of parts authorized for unit maintenance. Direct support repair consists of replacing gore sections.
F	Repair by darning, retaking, restitching splice edge binding and repairing grommets. Replacement of parts authorized for unit maintenance.



## APPENDIX C

### REPAIR PARTS AND SPECIAL TOOLS LIST

#### Section I. INTRODUCTION

##### C-1. Scope.

This RPSTL lists and authorizes spares and repair parts; special tools; special test, measurement, and diagnostic equipment (TMDE); and other special support equipment required for performance of unit and intermediate direct support (DS) maintenance of the 22-Foot Cargo Extraction Parachute. It authorizes the requisitioning, issue, and disposition of spares, repair parts and special tools as Indicated by the source, maintenance and recoverability (SMR) codes.

##### C-2. General.

In addition to Section I, Introduction, this Repair Parts and Special Tools List is divided into the following sections:

*a. Section II. Repair Parts List.* A list of spares and repair parts authorized by this RPSTL for use in the performance of maintenance. The list also includes parts which must be removed for replacement of the authorized parts. Parts lists are composed of functional groups in ascending alphanumeric sequence, with the parts in each group listed in ascending figure and item number sequence. Bulk materials are listed in name sequence. Repair parts kits are listed separately in their own functional group within Section II. Repair parts for repairable special tools are also listed in this section. Items listed are shown on the associated illustration(s) figure(s).

*b. Section III. Special Tools List.* A list of special tools, special TMDE, and other special support equipment authorized by this RPSTL (as indicated by Basis of Issue (BOI) information in DESCRIPTION AND USABLE ON CODE column for the performance of maintenance).

*c. Section IV. Cross Reference Indexes.* A list, in National Item identification Number (NIIN) sequence, of all National stock numbered items appearing in the listing, followed by a list in alphanumeric sequence of all part numbers appearing in the listings. National stock numbers and part numbers are cross-referenced to each illustration figure and item number appearance.

##### C-3. Explanation of Columns (Sections II and III).

*a. ITEM NO. (Column 1).* Indicates the number used to identify items called out in the Illustration.

**C-3. Explanation of Columns (Sections II and III) (cont).**

b. *SMR CODE (Column 2)*. The Source, Maintenance, and Recoverability (SMR) code is a 5-position code containing supply/requisitioning information, maintenance category authorization criteria, and disposition instructions, as shown in the following breakout:

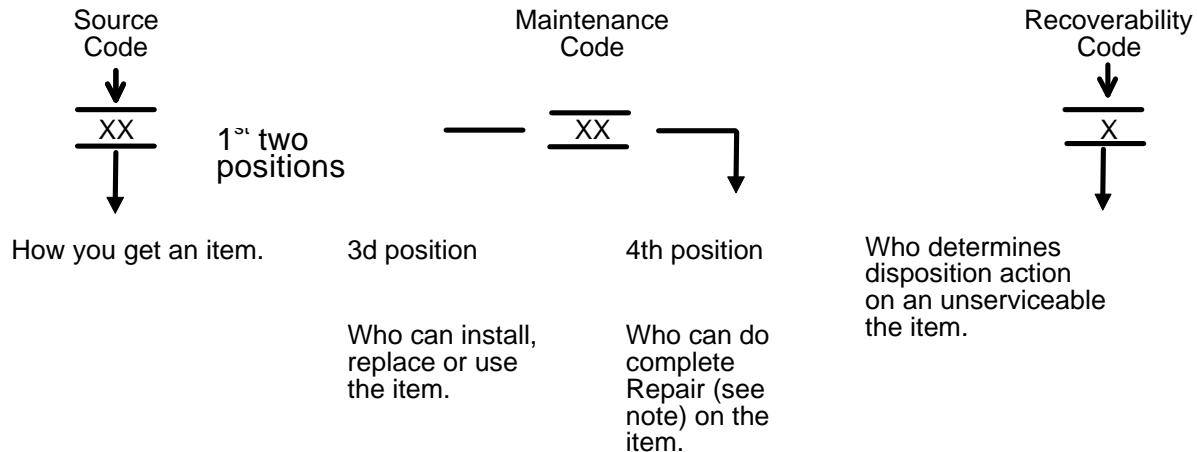

\*Complete Repair: Maintenance capacity, capability, and authority to perform all the corrective maintenance tasks of the "Repair" function in a use/user environment in order to restore serviceability to a failed item.

(1) *Source Code*. The source code tells you how to get an item needed for maintenance, repair, or overhaul of an end item/equipment. Explanations of source codes follows:

Code	Explanation
PA	Stocked items: use the applicable NSN to request/requisition items with these source codes. They are authorized to the category indicated by the code entered in the 3d position of the SMR code.  <b>**NOTE:</b> Items coded PC are subject to deterioration. Items with these codes are not to be requested/requisitioned individually. They are part of a kit which is authorized to the maintenance category indicated in the 3d position of the SMR code. The complete kit must be requisitioned and applied.
PB	
PC **	
PD	
PE	
PF	
PG	
KD	
KF	
KB	
Code	Explanation
MO - (Made at unit/ AVUM Level)	Items with these codes are not to be requested/requisitioned individually. They must be made from bulk material which is identified by the part number in the DESCRIPTION and USABLE ON CODE (UOC) column and listed in the Bulk Material group of the repair parts list in the RPSTL. If the item is authorized to you by the 3d position code of the SMR code, but the source code indicates it is made at a higher level, order the item from the higher level of maintenance.
MF - (Made at DSI AVUM Level)	
MH - (Made at GS Level)	
ML - (Made at Spe- cialized Repair Activity)	
MD - (Made at Depot)	



Code	Explanation
AO-(Assembled by unit/AVUM Level) AF-(Assembled by DSI/VIM Level) AH-(Assembled by GS Category) AL-(Assembled by SRA) AD-(Assembled by Depot)	 <p>Items with these codes are not to be requested/requisitioned individually. The parts that make up the assembled item must be requisitioned or fabricated and assembled at the level of maintenance indicated by the source code. If the 3d position code of the SMR code authorizes you to replace the item, but the source code indicates the item assembled at a higher level, order the item from the higher level of maintenance.</p>

Code	Explanation
XA — XB — XC — XD —	<p>Do not requisition an "XA"-coded item. Order its next higher assembly. (Also, refer to the NOTE below.)</p> <p>If an "XB" item is not available from salvage, order it using the FSCM and part number given.</p> <p>Installation drawing, diagram, instruction sheet, field service drawing, that is identified by manufacturer's part number.</p> <p>Item is not stocked. Order an "XD"-coded item through normal supply channels using the FSCM and part number given, if no NSN is available.</p>

**NOTE**

Cannibalization or controlled exchange, when authorized, may be used as a source of supply for items with the above source codes, except for those source coded "XA" or those aircraft support items restricted by requirements of AR 750-1.

(2) *Maintenance Code.* Maintenance codes tell you the level(s) of maintenance authorized to USE and REPAIR support items. The maintenance codes are entered in the third and fourth positions of the SMR Code as follows:

(a) The maintenance code entered in the third position tells you the lowest maintenance level authorized to remove, replace, and use an item. The maintenance code entered in the third position will indicate authorization to one of the following levels of maintenance.

Code	Application/Explanation
C — O — F — H — L — D —	<p>Crew or operator maintenance done within unit or aviation unit maintenance.</p> <p>Unit or aviation unit category can remove, replace, and use the item.</p> <p>Direct support or aviation intermediate level can remove, replace, and use the item.</p> <p>General support level can remove, replace, and use the item.</p> <p>Specialized repair activity can remove, replace, and use the item.</p> <p>Depot level can remove, replace, and use the item.</p>

**C-3. Explanation of Columns (Sections II and III) (cont).**

(b) The maintenance code entered in the fourth position tells whether or not the item is to be repaired and identifies the lowest maintenance level with the capability to do complete repair (i.e., perform all authorized functions.) (NOTE: Some limited repair may be done on the item at a lower level of maintenance, if authorized by the Maintenance Allocation Chart (MAC) and SMR code.) This position will contain one of the following maintenance codes.

Code	Application/Explanation
O —	Unit or aviation unit is the lowest level that can do complete repair of the item.
F —	Direct support or aviation intermediate is the lowest level that can do complete repair of the item.
H —	General support is the lowest level that can do complete repair of the item.
L —	Specialized repair activity (designate the specialized repair activity) is the lowest level that can do complete repair of the item.
D —	Depot is the lowest level that can do complete repair of the item.
Z —	Nonreparable. No repair is authorized.
B —	No repair is authorized. (No parts or special tools are authorized for the maintenance of a "B" coded item.) However, the item may be reconditioned by adjusting, lubricating, etc., at the user level.

(3) *Recoverability code.* Recoverability codes are assigned to items to indicate the disposition action on unserviceable items. The recoverability code is entered in the fifth position of the SMR Code as follows:

Recoverability codes	Application/Explanation
Z —	Nonreparable item. When unserviceable, condemn and dispose of the item at the level of maintenance shown in 3d position of SMR Code.
O —	Reparable item. When uneconomically repairable, condemn and dispose of the item at unit or aviation unit level.
F —	Reparable item. When uneconomically repairable, condemn and dispose of the item at the direct support or aviation intermediate level.
H —	Reparable item. When uneconomically repairable, condemn and dispose of the item at the general support level.
D —	Reparable item. When beyond lower level repair capability, return to depot. Condemnation and disposal of item not authorized below depot level.
L —	Reparable item. Condemnation and disposal not authorized below specialized repair activity (SRA).
A —	Item requires special handling or condemnation procedures because of specific reasons (e.g., precious metal content, high dollar value, critical material, or hazardous material). Refer to appropriate manuals/directives for specific instructions.

c. *FSCM (Column 3).* The Federal Supply Code for Manufacturer (FSCM) is a 5-digit numeric code which is used to identify the manufacturer, distributor, or Government agency, etc., that supplies the item.

d. Part Number (Column (4)). Indicates the primary number used by the manufacturer (individual, company, firm, corporation, or Government activity), which controls the design and characteristics of the item by means of its engineering drawings, specifications, standards, and Inspection requirements to identify an item or range of items.

#### NOTE

When you use a NSN to requisition an item, the item you receive may have a different part number from the part ordered.

e. Description and Usable on Code (UOC) (Column (5)). This column includes the following information:

- (1) The Federal item name and, when required, a minimum description to identify the Item.
- (2) The physical security classification of the item is indicated by the parenthetical entry, (insert applicable physical security classification abbreviation, e.g., Phy Sec CI (C)- Confidential, Phy Sec CI (S)-Secret, Phy Sec CI (T)-Top Secret.
- (3) Items that are included in kits and sets are listed below the name of the kit or set.
- (4) Spare/repair parts that make up an assembled item are listed immediately following the assembled item line entry.
- (5) Part numbers for bulk materials are referenced in this column in the line item entry for the item to be manufactured/fabricated.
- (6) When the item is not used with all serial numbers of the same model, the effective serial numbers are shown on the last line(s) of the description (before UOC).
- (7) The usable on code, when applicable (see paragraph 5, Special Information).
- (8) In the Special Tools List section, the basis of issue (BOI) appears as the last line(s) in the entry for each special tool, special TMDE, and other special support equipment. When density of equipments supported exceeds density spread indicated in the basis of issue, the total authorization is increased proportionately.
- (9) The statement "End of Figure" appears just below the last item description in Column 5 for a given figure in Section II.
- (10) The indenture shown as dots, appearing before the repair part, indicates that the item is a repair part of the next higher assembly.

f. Qty (Column (6)). The Qty (quantity per figure column) indicates the quantity of the item used In the breakout shown on the illustration figure, which is prepared for a functional group, subfunctional group, or an assembly. A "V" appearing in the column in lieu of a quantity indicates that the quantity is variable and may vary from application to application.

**C-4. Explanation of Columns (Sect. IV).**

a. NATIONAL STOCK NUMBER (NSN) INDEX.

(1) *STOCK NUMBER column* (5). This column lists the NSN by National item identification number (NIIN) sequence. The NIIN consists of the last nine digits of the NSN (i.e.

NSN
(53051-064-1467)
NIIN

When using this column to locate an item, ignore the first 4 digits of the NSN. However, the complete NSN should be used when ordering items by stock number.

(2) *FIG. column.* This column lists the number of the figure where the item is identified/ located. The figures are in numerical order in Section II and Section III.

(3) *ITEM column.* The item number identifies the item associated with the figure listed in the adjacent FIG. column. This item is also identified by the NSN listed on the same line.

b. PART NUMBER INDEX. Part numbers in this index are listed by part number in ascending alphanumeric sequence (i.e., vertical arrangement of letter and number combination which places the first letter or digit of each group in order A through Z, followed by the numbers 0 through 9 and each following letter or digit in like order).

(1) *FSCM column.* The Federal Supply Code for Manufacturer (FSCM) is a 5-digit numeric code used to identify the manufacturer, distributor, or Government agency, etc., that supplies the Item.

(2) *PART NUMBER column.* Indicates the primary number used by the manufacturer (individual, firm, corporation, or Government activity), which controls the design and characteristics of the Item by means of its engineering drawings, specifications standards, and inspection requirements to Identify an item or range of items.

(3) *STOCK NUMBER column.* This column lists the NSN for the associated part number and manufacturer identified in the PART NUMBER and FSCM columns to the left.

(4) *FIG. column.* This column lists the number of the figure where the item is identified/located in Section II and III.

(5) *ITEM column* The item number is that number assigned to the item as it appears in the figure referenced in the adjacent figure number column.

**C-5. Special Information.**

a. USABLE ON CODE. The usable on code appears in the lower left corner of the Description column heading. Usable on codes are shown as "UOC"... "in the Description Column (justified left) on the first line applicable item description/nomenclature. Uncoded items are applicable to all models.

Identification of the usable on codes used in the RPSTL are:

Code	Used on
DWV	1670-01-063-3716
DWU	1670-00-687-5458

b. FABRICATION INSTRUCTIONS. Bulk materials required to manufacture items are listed in the Bulk Material Functional Group of this RPSTL. Part numbers for bulk materials are also referenced in the description column of the line item entry for the item to be manufactured/fabricated. Detailed fabrication instructions for items source codes to be manufactured or fabricated are found in Chapter 2, Section VI of this manual.

c. ASSEMBLY INSTRUCTION. Detailed assembly instructions for items source coded to be assembled from component spare/repair parts are found in Chapter 2, Section III of this manual. Items that make up the assembly are listed immediately following the assembly item entry or reference is made to an applicable figure.

d. INDEX NUMBERS. Items which have the word BULK in the figure column will have an index number shown in the item number column. This index number is a cross-reference between the National Stock Number/Part Number Index and the bulk material list in Section II.

**C-6. How to Locate Repair Parts.**

a. When National Stock Number or Part Number is Not Known.

(1) *First*. Using the table of contents, determine the assembly group or subassembly group to which the item belongs. This is necessary since figures are prepared for assembly groups and subassembly groups, and listings are divided into the same groups.

(2) *Second*. Find the figure covering the assembly group or subassembly group to which the item belongs.

(3) *Third*. Identify the items on the figure and note the item number.

(4) *Fourth*. Refer to the Repair Parts List for the figure to find the part number

(5) *Fifth*. Refer to the Part Number Index to find the NSN, if assigned.

b. When National Stock Number of Part Number is Known:

(1) *First*. Using the Index of National Stock Numbers and Part Numbers, find the pertinent National Stock Number or Part Number. The NSN index is in National Item Identification Number (NIIN) sequence (see 4.1(1)). The part numbers in the Part Number index are listed in ascending alphanumeric sequence (see 4.b). Both indexes cross-reference you to the illustration figure and item number of the item you are looking for.

(2) *Second.* After finding the figure and item number, verify that the item is the one you're looking for, then locate the item number in the repair parts list for the figure.

**C-7. Abbreviations.**

Abbreviations	Explanations
EA	Each
FT	Foot/Feet
IN.	Inch/Inches
LG	Long
MTG	Mounting
NF	National Fine (Thread)



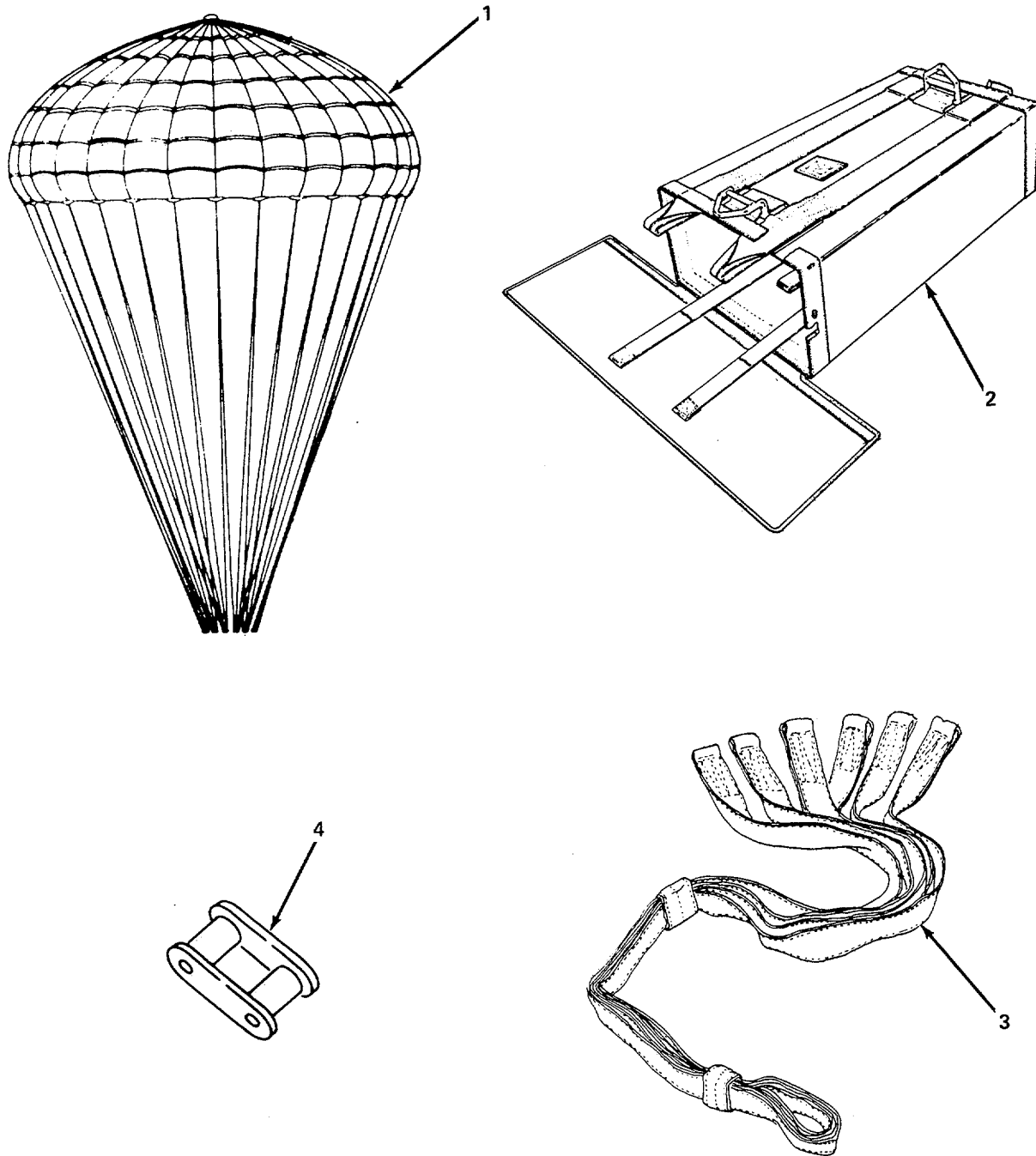

4728-084

Figure C-1. 22-Foot Diameter Cargo Extraction Parachute.

(C-9 blank)/C-10



**SECTION II**

**ARMY TM 10-1670-279-23&P  
AIR FORCE T.O. 13C5-27-2  
NAVY NAVAIR 13-1-28**

**Section II. REPAIR PARTS LIST**

(1) ITEM NO.	(2) SMR CODE	(3) FSCM	(4) PART NUMBER	(5) DESCRIPTION AND USABLE ON CODE(UOC)	(6) QTY
				GROUP 00 PARACHUTE CARGO TYPE, 22-FOOT DIAMETER, CARGO EXTRACTION	
				FIG. C-1 22-FOOT DIAMETER CARGO EXTRACTION PARACHUTE 11-1-2584	
1	XAOFF	98750	52K6329	CANOPY, CARGO EXTRACTION, 22-FOOT DIAMETER .....	1
2	PAOOO	98750	58J6099	DEPLOYMENT BAG, PARACHUTE .....	1
3	PA000	81337	11-1-2582	ADAPTER WEB, PARACHUTE .....	1
				UOC: DWV	
4	PAOZZ	98750	59C6196	LINK ASSEMBLY, QUICK RELEASE, TYPE IV .....	1
				UOC: DWU	
				END OF FIGURE	

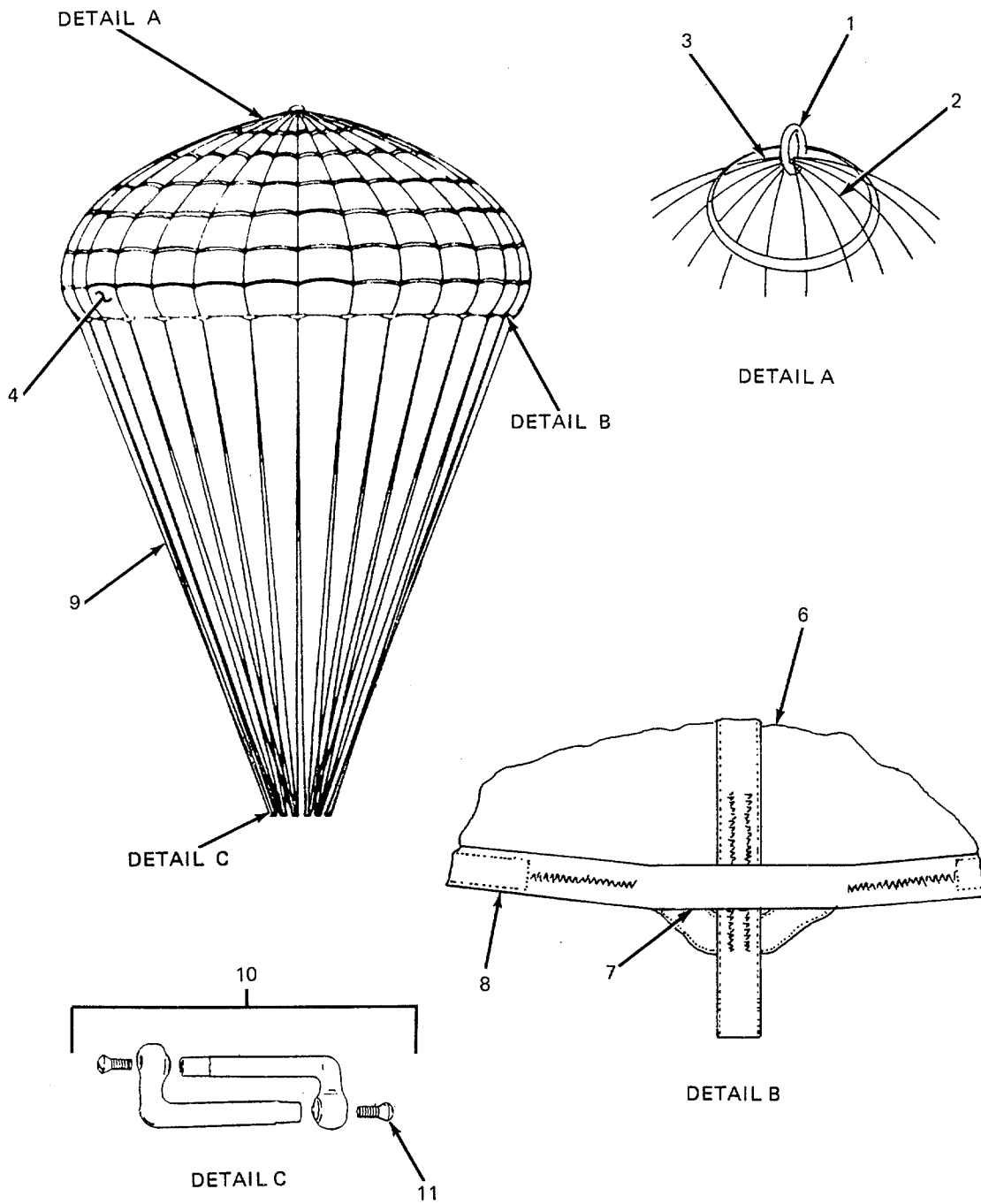

4728-085

Figure C-2. 22-Foot Diameter Canopy, Cargo Extraction Parachute.

SECTION II

ARMY TM 10-1670-279-23&P  
 AIR FORCE T.O. 13C5-27-2  
 NAVY NAVAIR 13-1-28

(1) ITEM NO.	(2) SMR CODE	(3) FSCM	(4) PART NUMBER	(5) DESCRIPTION AND USABLE ON CODE(UOC)	(6) QTY
				GROUP 01 CANOPY, CARGO EXTRACTION PARACHUTE, 22-FOOT DIAMETER	
				FIG. C-2 22-FOOT DIAMETER CANOPY, CARGO EXTRACTION PARACHUTE, 52K6329	
1	M0000	98750	52K6329-21	LOOP, ATTACHMENT, MAKE FROM WEBBING, COTTON CLASS 2B, TYPE VIII, OD 1 3/4-IN W P/N MIL-W-5665 & THREAD, NYLON SIZE 3 TY 1 CL A, P/N V-T-295 .....	1
2	MFFFF	98750	52K6329-18	VENT LINE, MAKE FROM CORD NYLON TY V, P/N MIL-C-7515 & THREAD NYLON SIZE E TY 1 CL A, P/N V-T-295 .....	12
3	MFFFF	98750	52K6329-19	LINE, CENTER, BRIDLE, MAKE FROM CORD NYLON TY V OD P/N MIL-W-7515 & THREAD NYLON SIZE E TY 1 CL A, P/N V-T-295 .....	1
4	MFFFF	98750	52D6330-1/7	GORE, PANEL, CANOPY, MAKE FROM CLOTH NYLON PARACHUTE TY II OD 3.50 OZ P/N MIL-C-7350 & THREAD NYLON SIZE E TY 1 CL A P/N V-T-295 .....	168
5	M0000	98750	52K6329-4	PANEL EDGE REINFORCEMENT, MAKE FROM TAPE NYLON, MILT-5038, TYPE IV OD & THREAD NYLON SIZE 3 TY 1 CL A, P/N V-T-295 .....	2
6	M0000	98750	52K6329-16	RADIAL TAPE, MAKE FROM TAPE NYLON TYPE IV OD P/N MIL-T-5038 & THREAD NYLON SIZE E TY 1 CLA, P/N V-T-295 .....	28
7	M0000	98750	52K6329-20	POCKET BAND, MAKE FROM TAPE NYLON TY IV P/N MIL-T-5038 OR CORD, CORELESS NYLON TY V OD P/N MIL-C-7515 & THREAD NYLON SIZE E P/N V-T-295 .....	28
8	M0000	98750	52K6329-13	SKIRT REINFORCEMENT, MAKE FROM WEBBING NYLON TUBULAR 1 IN W OD P/N MIL-W-5625 & THREAD, NYLON SIZE ETY 1 CL4 .....	1
9	MFFFF	98750	52K6329-17	LINE, 'SUSPENSION', MAKE FROM CORD NYLON CORELESS TY V OD P/N MIL-C-7515 & THREAD NYLON SIZE E TY 1 CL A, P/N V-T-295	
10	PA000	96906	MS22002-1	.LINK PARACHUTE .....	6
11	PAOZZ	96906	MS22002-7	..SCREW, SLOTTED .....	12
				END OF FIGURE	

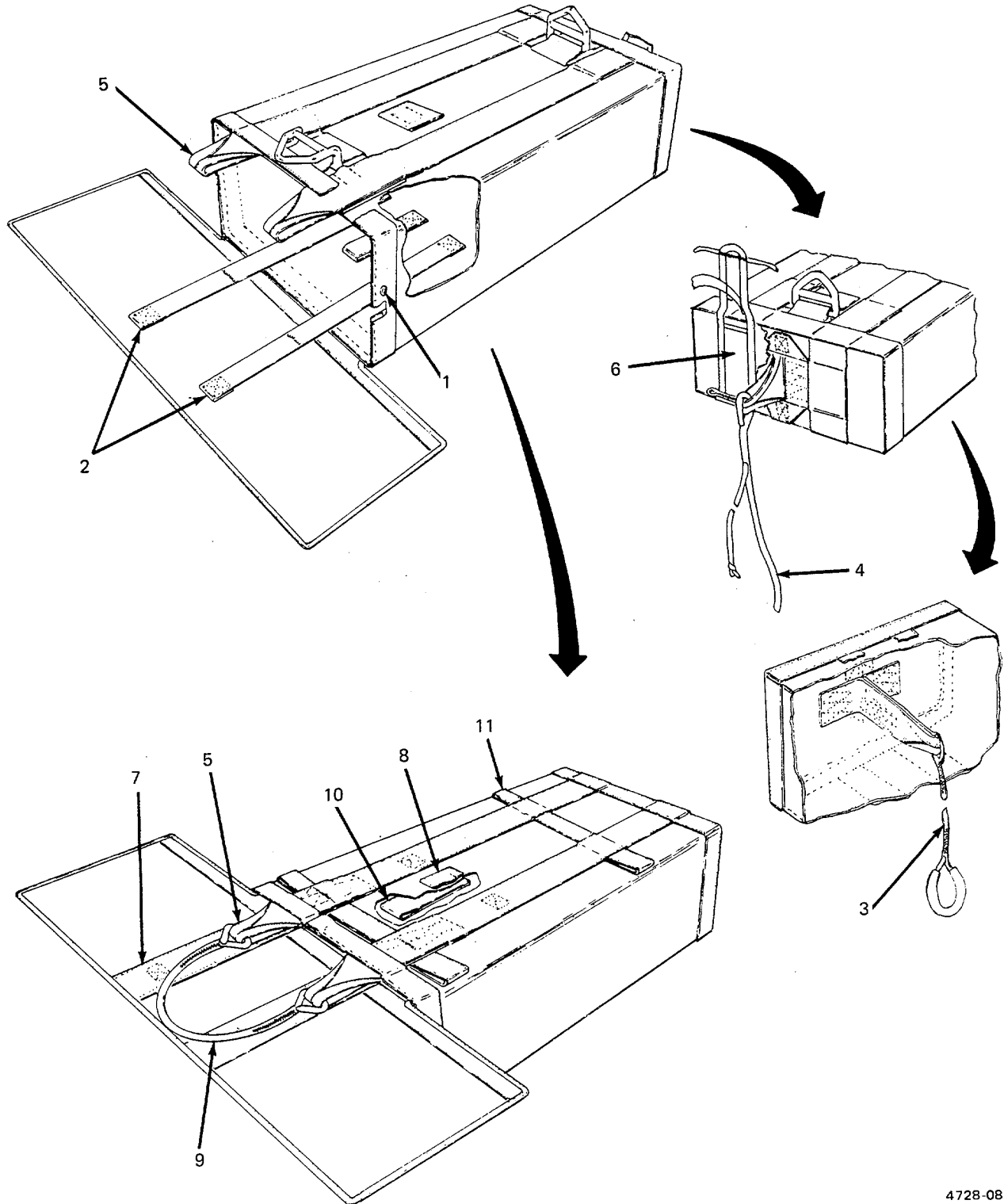

4728-086

Figure C-3. Deployment Bag.

SECTION II

ARMY TM 10-1670-279-23&P  
 AIR FORCE T.O. 13C5-27-2  
 NAVY NAVAIR 13-1-28

(1) ITEM NO.	(2) SMR CODE	(3) FSCM	(4) PART NUMBER	(5) DESCRIPTION AND USABLE ON CODE(UOC)	(6) QTY
				GROUP 02 DEPLOYMENT BAG, PARACHUTE	
				FIG. C-3 DEPLOYMENT BAG 58J6099	
1	PA000	81349	MIL-G-16491	GROMMET, METALLIC, SIZE 0 TYPE 1 .....	2
2	M0000	81337	58J6099	KEEPER, RETAINER BAND, MAKE FROM WEBBING NYLON TY IV 1-IN-W P/N MIL-T-5038& THREAD NYLON SIZE 3 TY 1 CL A P/N V-T-295 .....	2
3	M0000	81337	58J6099-17	RETAINING LINE, MAKE FROM CORD NYLON CORELESS TY IV OD P/N MIL-C-7515 & THREAD, NYLON SIZE FF TY 1 CLA P/N V-T-295.....	1
	M0000	81337	58J6099-19	LINE, PENDULUM, MAKE FROM CORD, NYLON TY IV, OD P/N MIL-C-7515.....	1
5	M0000	81337	58J6099-15	LOOP, BAG CLOSING, MAKE FROM WEBBING NYLON TY VIII 1 23/32-IN-W P/N MIL-W-4088 & THREAD SIZE FF, TY 1 CLA P/N V-T-295 .....	4
6	PAOZZ	98750	54C6335	POCKET, INSPECTION DATA .....	1
7	M0000	81337	58J6099-11	REINFORCEMENT, RETAINER BAND KEEPER, MAKE FROM WEBBING NYLON TY VIII OD 1 23/32-IN-W P/N MIL-W-4088 & THREAD NYLON SIZE FF TY 1 CLA P/N V-T-295 .....	2
8	M0000	81337	58J6099-10	REINFORCEMENT, TIE LOOP, MAKE FROM WEBBING, NYLON TY IV 1 1/2 IN-W P/N MIL-T-5038 .....	2
9	M0000	98750	58J6099-18	SAFETY CORD, MAKE FROM MIL-C-7515, TYPE IV, OD & THREAD, NYLON SIZE E, TY 1 CLA, P/N U-T-295 .....	1
10	M0000	98750	58J6099-6	TIE LOOP, MAKE FROM WEBBING, NYLON, TYPE IV, 1-IN WIDE P/N MIL-T-5038 & THREAD, NYLON SIZE FF TY 1 CLA, V-T-295 .....	2
11	MOOZZ	98750	58J6099-6	LOOP, RETAINING, MAKE FROM MIL-C-5040, TYPE IV, OD & THREAD, NYLON, SIZE FF, TY 1 CLA, V-T-295 .....	16
				END OF FIGURE	

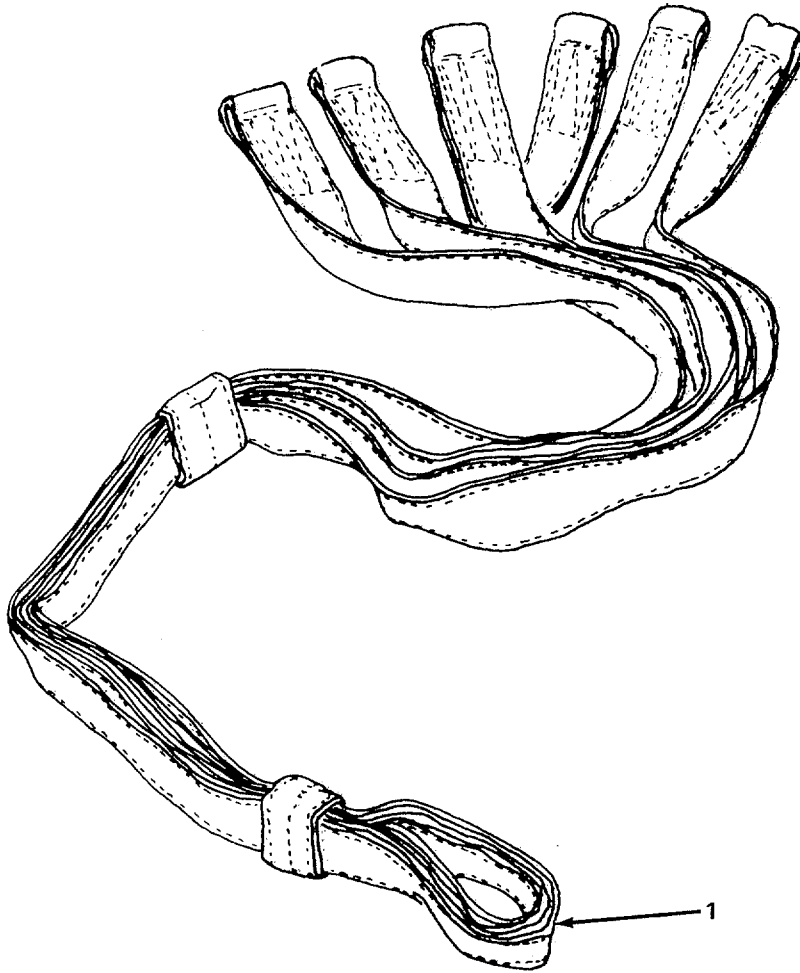

4728-087

**SECTION II**

**ARMY TM 10-1670-279-23&P  
 AIR FORCE T.O. 13C5-27-2  
 NAVY NAVAIR 13-1-28**

(1) ITEM NO.	(2) SMR CODE	(3) FSCM	(4) PART NUMBER	(5) DESCRIPTION AND USABLE ON CODE(UOC)	(6) QTY
1	MOOZZ	81337	11-1-2582-6	GROUP 03 ADAPTER WEB, EXTRACTION PARACHUTE  FIG. C-4 5-FOOT ADAPTER WEB 11-1-2582  BUFFER, LONG .....  END OF FIGURE	1

**SECTION II**

**ARMY TM 10-1670-279-23&P  
AIR FORCE T.O. 13C5-27-2  
NAVY NAVAIR 13-1-28**

(1) ITEM NO	(2) SMR CODE	(3) FSCM	(4) PART NUMBER	(5) DESCRIPTION AND USABLE ON CODE(UOC)	(6) QTY
				GROUP 05 BULK MATERIALS	
				FIG BULK	
1	PAOZZ	81349	MIL-C-7350	CLOTH, NYLON, PARACHUTE TYPE 1, 35 OZ NATURAL .....	V
2	PAOZZ	81349	MIL-C-7350	CLOTH, NYLON, PARACHUTE TYPE 1, 35 OZ, OD .....	V
3	PAOZZ	81349	MIL-C-7515	CORD, FIBROUS TYPE IV, OD .....	V
4	PAOZZ	81349	MIL-C-7515	CORD, CORELESS, TYPE V, OD .....	V
5	PAOZZ	81349	MIL-T-43566	TAPE, TEXTILE, TYPE 1, CLASS 4, 1 1/2-IN WIDE OD .....	V
6	PAOZZ	81349	MIL-T-5038	TAPE, TEXTILE, TYPE III, 1/2-IN WIDE .....	V
7	PAOZZ	81349	MIL-T-5038	TAPE, TEXTILE, TYPE II, 3/4-IN WIDE .....	V
8	PAOZZ	81349	V-T-295	THREAD, TYPE I, SIZE E, CLASS A, OD .....	V
9	PAOZZ	81349	V-T-295	THREAD, TYPE I, SIZE E, CLASS, A WHITE .....	V
10	PAOZZ	81349	V-T-295	THREAD, TYPE I, SIZE FF, CLASS A, OD .....	V
11	PAOZZ	81349	V-T-295	THREAD, TYPE I, SIZE FF, CLASS A, WHITE .....	V
12	PAOZZ	81349	V-T-295	THREAD, TYPE I, SIZE 3, CLASS A, OD .....	V
13	PAOZZ	81349	V-T-295	THREAD, TYPE I, SIZE 3, CLASS A, WHITE .....	V
14	PAOZZ	81349	MIL-W-5625	WEBBING, NYLON, TUBULAR, 1-IN WIDE OD .....	V
15	PAOZZ	81349	MIL-T-5038	WEBBING, NYLON, TYPE IV, 1-IN WIDE OD .....	V
16	PAOZZ	81349	MIL-T-5038	WEBBING, NYLON, TYPE IV, 1 1/2-IN WIDE OD .....	V
17	PAOZZ	81349	MIL-2-4088	WEBBING, NYLON TYPE VIII, 1 23/32-IN WIDE OD .....	V
18	PAOZZ	81349	MIL-2-5665	WEBBING, TEXTILE, TYPE VIII, CLASS 2B, OD .....	V
19	PAOZZ	81349	MIL-W-4088	WEBBING, NYLON, TYPE VII .....	V
				END OF FIGURE	

**Section III. SPECIAL TOOLS LIST**

NOT APPLICABLE

**Change 2 C-18**



## CROSS-REFERENCE INDEXES

## NATIONAL STOCK NUMBER INDEX

STOCK NUMBER	FIG.	ITEM	STOCK NUMBER	FIG.	ITEM
8315-00-176-8083	BULK	7	8310-00-262-2770	BULK	9
8305-00-205-1478	BULK	1	8310-00-262-2772	BULK	8
1670-00-217-2421	C-2	10	8305-00-263-2472	BULK	16
5320-00-231-6589	C-3	1	8310-00-267-3024	BULK	11
8310-00-227-1244	BULK	10	8310-00-267-3027	BULK	12
8310-00-248-9714	BULK	13	8305-00-268-2455	BULK	14
8315-00-253-6292	BULK	5	1670-00-308-4221	C-3	6
8315-00-255-7673	BULK	6	1670-00-733-4883	C-1	2
8305-00-260-2564	BULK	18	1670-00-778-9808	C-1	3
8305-00-261-8579	BULK	15	8305-00-782-6734	BULK	19
8305-00-261-8585	BULK	17	1670-00-783-5988	C-1	4
4020-00-262-2020	BULK	3	4020-00-965-0473	BULK	4

## CROSS-REFERENCE INDEXES

## PART NUMBER INDEX

FSCM	PART NUMBER	STOCK NUMBER	FIG.	ITEM
81349	MIL-C-7350	8305-00-205-1478	BULK	1
81349	MIL-C-7350		BULK	2
81349	MIL-C-7515	4020-00-262-2020	BULK	3
81349	MIL-C-7515	4020-00-965-0473	BULK	4
81349	MIL-G-26491	5320-00-231-6589	C-3	1
81349	MIL-T-5038	8315-00-255-7673	BULK	6
81349	MIL-T-5038	8315-00-176-8083	BULK	7
81349	MIL-T-43566	8315-00-253-6292	BULK	5
81349	MIL-T-5038	8305-00-263-2472	BULK	16
81349	MIL-W-4088	8305-00-261-8585	BULK	17
81349	MIL-W-4088	8305-00-782-6734	BULK	19
81349	MIL-W-5038	8305-00-261-8579	BULK	15
81349	MIL-W-5625	8305-00-268-2455	BULK	14
81349	MIL-W-5665	8305-00-260-2564	BULK	18
96906	MS22002-1	1670-00-217-2421	C-2	10
96906	MS2202-7	5305-00-269-6657	C-2	11
81349	V-T-295	8310-00-227-1244	BULK	10
81349	V-T-295	8310-00-262-2772	BULK	8
81349	V-T-295	8310-00-262-2770	BULK	9
81349	V-T-295	8310-00-267-3024	BULK	11
81349	V-T-295	8310-00-267-3027	BULK	12
81349	V-T-295	8310-00-248-9714	BULK	13
98750	52K6329		C-1	2
98750	52K6329-46		C-2	5
98750	52K6329-16		C-2	6
98750	52K6329-13		C-2	8
98750	52K6329-17		C-2	9
98750	52K6329-18		C-2	2
98750	52K6329-19		C-2	3
98750	52K6329-20		C-2	7
98750	52K6329-21		C-2	1
98750	52D6330-1/7		C-2	4
98750	54C6335	1670-00-308-4221	C-3	6
81337	58J6099	1670-00-733-4883	C-1	2
81337	58J6099		C-3	2
81337	58J6099-10		C-3	8
81337	58J6099-11		C-3	7
81337	58J6099-15		C-3	5
81337	58J6099-17		C-3	3
81337	58J6099-19		C-3	4
	59C6196	1670-00-783-5988	C-1	4
	11-1-2582	1670-00-778-9808	C-1	3

APPENDIX D

EXPENDABLE/DURABLE SUPPLIES AND MATERIALS LIST

Section I. INTRODUCTION

**D-1. Scope.** This appendix lists expendable supplies and materials you will need to operate and maintain the 22-Foot Diameter Cargo Extraction Parachute. These items are authorized to you by CTA 50-970, Expendable Items (Except Medical, Class V, Repair Parts, and Heraldic Items).

**D-2. Explanation of Columns.**

a. Column (1)-Item Number. This number is assigned to the entry in the listing and is referenced in the narrative instructions to identify the material (e.g., "Use Cloth, Abrasive, Item 3, App. D").

b. Column (2)-Level. This column identifies the lowest level of maintenance that requires the listed item. (Enter as applicable).

- C – Operator/Crew
- O – Organizational Maintenance-Unit Maintenance
- F – Direct Support Maintenance-Intermediate Maintenance
- H – General Support Maintenance-Intermediate Maintenance
- D – Depot Maintenance

c. Column (3)-National Stock Number. This is the National stock number assigned to the item; use it to request or requisition the item.

d. Column (4)-Description. Indicates the Federal item name, and, if required, a description to identify the item.

e. Column (5)-Unit of Measure (U/M). Indicates the measure used in performing the actual maintenance function. This measure is expressed by a two-character alphabetical abbreviation (e.g., ea, in, pr). If the unit of measure differs from the unit of issue, requisition the lowest unit of issue that will satisfy your requirements.

Section II. EXPENDABLE/DURABLE SUPPLIES AND MATERIALS LIST

(1) Item number	(2) Level	(3) National stock number	(4) Description	(5) U/M
1	0	1670-00-568-0323	Band, Rubber Retainer (81349) MIL-B-1832, TY I	BX
2	0	9160-00-253-1171	Beeswax, Technical 1 Lb (81349) C-B-191	LB
3	0	5350-00-221-0872	Cloth, Abrasive, Ferric Oxide & Quartz (81349) P-C-458	SH

**EXPENDABLE/DURABLE SUPPLIES AND MATERIALS LIST (cont)**

(1) Item number	(2) Level	(3) National stock number	(4) Description	(5) U/M
4	0	8305-00-765-2863	Cloth, Nylon, Duck, 7.25 Oz MIL-C-7219 (81349)	YD
5	0	8305-00-205-1478	Cloth, Nylon, Parachute, Type I 3.5 Oz, Natural, 36 Inch (81349) MIL-C-7350	FT
6	0	4020-00-965-0473	Cord, Nylon, Type V, OD, (81349) MIL-C-7515	YD
7	0	4020-00-262-2020	Cord, Nylon, Type IV, OD (81349) MIL-C-7515	YD
8	0	7930-00-281-4731	Dishwashing Compound, Hand, Flake (81348) P-D-410	LB
9	0	7510-00-286-5362	Ink, Marking, Parachute, Strata- Blue (81349) MIL-1-6903	PT
10	0	9150-00-168-2000	Lubricant, Solid Film	
11	0	7520-00-230-2734	Marker, Felt Tip, Black (81348) GG-M-0014	EA
12	0		Medicine Dropper	EA
13	0		Paper, Three-Color, PH	SH
14	0	7520-00-491-2917	Pen, Ballpoint (81348) GG-B-0060	EA
15	0	7510-00-240-1525	Pencil, Marking Aid, White (81348) A-A-87	EA
16	0	7510-00-264-4612	Pencil, Marking Aid, Yellow (81348) A-A-87	EA
17	0	7920-00-205-3570	Rag, Wiping (81348) DDD-R-30	BE
18	0	6630-00-442-8000	Spool with Color Chart	EA
19	0	9310-00-160-7858	Stencil Board, Oiled, Type II (81348) UU-S-625	SH
20	0	8315-00-253-6292	Tape, Cotton, Type I, 1 1/2 In. OD (81349) MIL-T-43566, Class 4	YD

EXPENDABLE/DURABLE SUPPLIES AND MATERIALS LIST (cont)

(1) Item number	(2) Level	(3) National stock number	(4) Description	(5) U/M
21	0	8315-00-176-8083	Tape, Nylon, Type III, 3/4 In. OD (81349) MIL-T-5038	YD
22	0	8315-00-255-7673	Tape, Nylon, Type III, 112 In. OD (81349) MIL-T-5038	YD
23	0	7510-00-633-0199	Tape, Pressure Sensitive, 1-In. (81348) PPP-T-60	RL
24	0	6810-00-270-9982	Tetrachloroethylene, Technical (81348) 0-T-236	RL
25	0	8310-00-917-3945	Thread, Cotton, Ticket No. 8/7, (81348) V-T-276	YD
26	0	8310-00-262-2770	Thread, Nylon, Size E, Natural White (81348) V-T-295 Type I, Class A	YD
27	0	8310-00-262-2772	Thread, Nylon, Size E, OD (81348) V-T-295 Type I, Class A	YD
28	0	8310-00-267-3024	Thread, Nylon, Size FF, Natural White (81348) V-T-295 Type I, Class A	YD
29	0	8310-00-227-1244	Thread, Nylon, Size FF, OD (81348) V-T-295 Type I, Class A	YD
30	0	8310-00-248-9714	Thread, Nylon, Size 3, Natural White (81348) V-T-295 Type I, Class A	YD
31	0	8310-00-267-3027	Thread, Nylon, Size 3, OD (81348) V-T-295 Type I, Class A	YD
32	0	9160-00-285-2044	Wax, Paraffin, 1 Lb Cake (81348) VV-W-95, Type I, Grade A	LB
33	0	8305-00-268-2411	Webbing, Cotton, Type I, 1/4 Inch (81349) MIL-T-5661	FT
34	0	8305-00-260-2565	Webbing, Cotton, Type VIII, OD (81349)	YD
35	0	8305-00-753-6086	Webbing, Cotton, Type X, OD (81349) MIL-W-5665 Class 2B	YD

**EXPENDABLE/DURABLE SUPPLIES AND MATERIALS LIST (cont)**

(1) Item number	(2) Level	(3) National stock number	(4) Description	(5) U/M
36	0	8305-00-261-8579	Webbing, Nylon, Type IV, 1 In., OD (81349) MIL-T-5038	YD
37	0	8305-00-261-8585	Webbing, Nylon, Type VIII, OD (81349) MIL-W-4088	YD
38	0	8305-00-263-2472	Webbing, Nylon, Type IV, OD 1 1/2 In. (81349), MIL-T-5038	YD
39	0	8305-00-268-2455	Webbing, Nylon, Tubular, 1 In., (81349) MIL-W-5625	YD
40	0	8305-00-782-6734	Webbing, Nylon, Type VII	YD

APPENDIX E

ILLUSTRATED LIST OF MANUFACTURED ITEMS

Complete Instructions for making items authorized to be manufactured or fabricated are located in Chapter 2, Section VII of this manual. Fabricate a splicing aid in accordance with figure E-1.

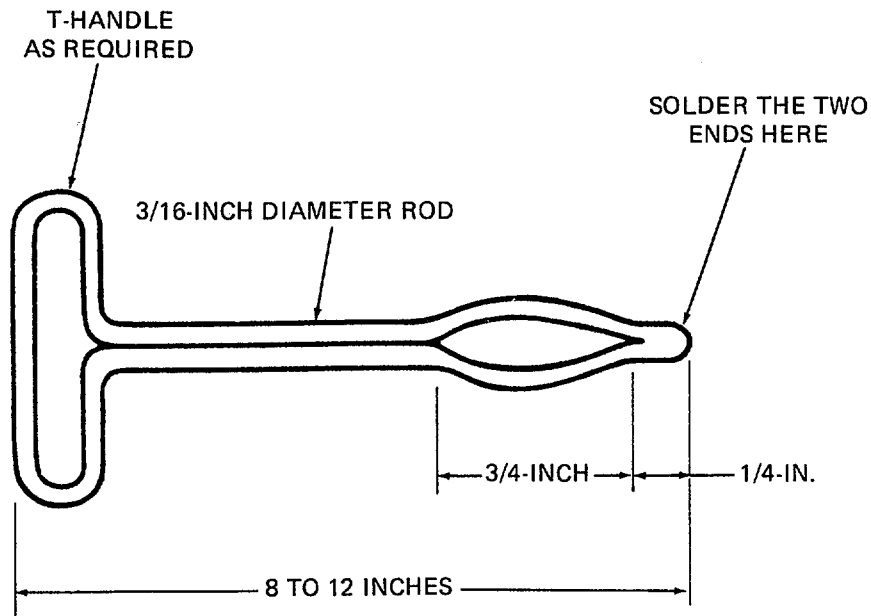

SPLICING AND FABRICATIONS

4727-100

Figure E-1. Splicing Aid Fabrication.





INDEX

Subject	Paragraph
<b>A</b>	
Acidity Test .....	2-14
Adapter Web .....	2-48, 2-49, 2-50
After-Use Receipt .....	2-6
Airing and Shakeout .....	2-11
Attaching Deployment Bag .....	2-8
Attaching Extraction Line .....	2-16m
Attachment Loop (Bridle Loop) .....	2-22
Appendices:	
A-References .....	A-1
B-Maintenance Allocation Chart (MAC), Tools and Test Equipment .....	B-1
C-Repair Parts and Special Tools List (RPSTL) .....	C-1
D-Expendable/Durable Supplies and Materials List .....	D-1
E-Illustrated List of Manufactured Items .....	E-1
Army Parachute Log Record .....	2-4d 2-16m
Assembling Parachute .....	28
<b>B</b>	
Bag Closing Loop (Bottom) .....	2-38
Bridle Centering Line .....	2-24
Bridle Loop (Attachment Loop) .....	2-22
Repair	
Replacement	
<b>C</b>	
Canopy Repair .....	2-21
Checking Unpacked Equipment After Shipment .....	2-7
Cleaning and Drying .....	2-12
Closing Deployment Bag .....	2-16l
Common Tools and Equipment .....	2-1
Connector Link .....	2-33
<b>D</b>	
Deployment Bag .....	2-34
Deployment Bag Attaching Loop .....	2-35
Deployment Bag Main Strap .....	2-45
Deployment Bag Panels and Flaps .....	2-46
Deployment Retainer Band Keeper .....	2-36

**INDEX (cont)**

**D (cont)**

Subject	Paragraph
Deployment Bag Retaining Tie .....	2-16g, 237
Deployment Bag Safety Cord .....	2-42
Deployment Bag Stowage Flap Edge Binding .....	2-43
Deployment Bag Stowage Flap Edge Reinforcement .....	2-44
Deployment Bag Tie Loop and Reinforcement .....	241
Destruction of Army Materiel to Prevent Enemy Use .....	1-3
Differences Between Models .....	1-8

**E**

Equipment Characteristics, Capabilities and Features .....	1-6
Equipment Data .....	1-9
Extraction Line .....	2-51

**F**

Folding Canopy Gores .....	2-16h
Functional Description of Major Components .....	1-9

**G**

Gore Sections .....	2-26
Repair	
Replacement	
Grommet.....	2-35
Repair	
Replacement	

**H**

Initial Receipt .....	2-4
Inspection Data Pocket, Parachute .....	2-39
Inspection .....	2-13, 2-16a, 2-54
Inversion Removal .....	2-16d, 2-16e

**INDEX (cont)**

Subject	Paragraph
<b>J, K</b>	
<b>L</b>	
Locating Suspension Lines .....	2-16f
Location and Description of Major Components .....	1-7
Log Record, Parachute .....	2-4d
Longfolding Canopy .....	2-161
Lower Lateral Band Repair .....	2-29
<b>M</b>	
Maintenance Forms and Records .....	1-2
Marking and Restenciling .....	2-20
<b>N, O</b>	
<b>P</b>	
Packing the Parachute .....	2-16
Panel Edge Reinforcement .....	2-28
Pendulum Line .....	2-47
Pocket Band .....	2-30
Repair	
Replacement	
Preparing Parachute for Proper Layout .....	2-16c
<b>Q</b>	
<b>R</b>	
Radial Tape .....	2-27
Receipt of Used Parachute .....	2-5
Removing Inversion .....	2-16d, 2-16e
Removing Tangles .....	2-16f
Removing Turns .....	2-16f
Removing Twists .....	2-16f
Repair Parts .....	2-3
Reporting of Equipment Improvement Recommendations .....	1-5
Restenciling and Marking .....	2-20
Retainer Band Keeper Reinforcement .....	2-40
Rigger's Orientation .....	2-16b

INDEX (cont)

Subject	Paragraph
<b>S</b>	
Safety, Care and Handling .....	1-10
Safety Cord .....	2-42
Salt-Water Contamination Test .....	2-15
Scope of Manual .....	1-1
Searing and Waxing .....	2-19
Sewing Procedures .....	2-18
Shakeout and Airing .....	2-11
Special Tools, TMDE and Support Equipment .....	2-2
Storage and Shipment	
Preparation for .....	1-4
Storage .....	2-53
In-Storage Inspection .....	2-54
Shipment .....	2-55
Stowage Flap Edge Binding .....	2-43
Stowing Canopy .....	2-16j
Stowing Extraction Line.....	2-16n
Stowing Suspension Lines.....	2-16k
Suspension Line .....	2-31
Repair	
Replacement	
<b>T</b>	
Tie Loop and Tie Loop Reinforcement.....	2-41
<b>U</b>	
Unit and Intermediate Maintenance Procedures .....	2-10
Upper Lateral Band .....	2-25
Repair	
Replacement	
<b>V</b>	
Vent Lines.....	2-23
Repair	
Replacement	
<b>W</b>	
Waxing and Searing .....	2-19
<b>X, Y, Z</b>	

By Order of the Secretaries of the Army, Air Force and Navy

Official:

WILLIAM J. MEEHAN, II  
*Brigadier General, United States Army*  
*The Adjutant General*

CARL E. VUONO  
*General, United States Army*  
*Chief of Staff*

B. F. MONTOYA  
*Rear Admiral, CEC, US Navy*  
*Commander*  
*Naval Facilities Engineering Command*

Official:

ALFRED G. HANSEN  
*General, USAF, Commander, Air Force*  
*Logistics Command*

LARRY D. WELCH , *General USAF*  
*Chief of Staff*

**DISTRIBUTION:**

To be distributed in accordance with DA Form 12-25A, Unit and Direct Support Maintenance requirements for Parachute, Cargo, Type 22-ft diameter, Extraction.



## These are the instructions for sending an electronic 2028

The following format must be used if submitting an electronic 2028. The subject line must be exactly the same and all fields must be included; however, only the following fields are mandatory: 1, 3, 4, 5, 6, 7, 8, 9, 10, 13, 15, 16, 17, and 27.

From: "Whoever" whoever@avma27.army.mil

To: amssbriml@natick.army.mil

Subject: DA Form 2028

1. **From:** Joe Smith
2. **Unit** home
3. **Address:** 4300 Park
4. **City:** Hometown
5. **St:** MO
6. **Zip:** 77777
7. **Date Sent:** 19-OCT-93
8. **Pub no:** 55-2840-229-23
9. **Pub Title:** TM
10. **Publication Date:** 04-JUL-85
11. **Change Number:** 7
12. **Submitter Rank:** MSG
13. **Submitter FName:** Joe
14. **Submitter MName:** T
15. **Submitter LName:** Smith
16. **Submitter Phone:** 123-123-1234
17. **Problem:** 1
18. **Page:** 2
19. **Paragraph:** 3
20. **Line:** 4
21. **NSN:** 5
22. **Reference:** 6
23. **Figure:** 7
24. **Table:** 8
25. **Item:** 9
26. **Total:** 123
27. **Text:**

This is the text for the problem below line 27.





<b>RECOMMENDED CHANGES TO PUBLICATIONS AND BLANK FORMS</b> For use of this form, see AR 25-30; the proponent agency is ODISC4.						Use Part II (reverse) for Repair Parts and Special Tool Lists (RPSTL) and Supply Catalogs/Supply Manuals (SC/SM).	<b>DATE</b> 21 October 2003
<b>TO:</b> (Forward to proponent of publication or form) (Include ZIP Code) COMMANDER U.S. ARMY TANK-AUTOMOTIVE AND ARMAMENT COMMAND ATTN: AMSTA-LC-CECT 15 KANSAS STREET NATICK, MA 01760-5052						<b>FROM:</b> (Activity and location) (Include ZIP Code)  <i>PFC Jane Doe</i> <i>CO A 3<sup>rd</sup> Engineer BR</i> <i>Ft. Leonardwood, MO 63108</i>	
<b>PART I – ALL PUBLICATIONS (EXCEPT RPSTL AND SC/SM) AND BLANK FORMS</b>							
<b>PUBLICATION/FORM NUMBER</b> TM 10-1670-296-23&P				<b>DATE</b> 30 October 2002	<b>TITLE</b> Unit Manual for Ancillary Equipment for Low Velocity Air Drop Systems		
<b>ITEM NO.</b>	<b>PAGE NO.</b>	<b>PARA-GRAPH</b>	<b>LINE NO. *</b>	<b>FIGURE NO.</b>	<b>TABLE NO.</b>	<b>RECOMMENDED CHANGES AND REASON</b> <i>(Provide exact wording of recommended changes, if possible).</i>	
	0036 00-2				1	<i>In table 1, Sewing Machine Code Symbols, the second sewing machine code symbol should be MD ZZ not MD 22.</i>  <i>Change the manual to show Sewing Machine, Industrial: Zig-Zag; 308 stitch; medium-duty; NSN 3530-01-181-1421 as a MD ZZ code symbol.</i>	
<small>*Reference to line numbers within the paragraph or subparagraph.</small>							
<b>TYPED NAME, GRADE OR TITLE</b>  Jane Doe, PFC				<b>TELEPHONE EXCHANGE/AUTOVON, PLUS EXTENSION</b>  508-233-4141		<b>SIGNATURE</b>  Jane Doe <i>Jane Doe</i>	

<b>TO:</b> (Forward direct to addressee listed in publication) COMMANDER U.S. ARMY TANK-AUTOMOTIVE AND ARMAMENT COMMAND ATTN: AMSTA-LC-CECT 15 KANSAS STREET NATICK, MA 01760-5052	<b>FROM:</b> (Activity and location) (Include ZIP Code) <i>PFC Jane Doe</i> <i>CO A 3<sup>rd</sup> Engineer BR</i> <i>Ft. Leonardwood, MO 63108</i>	<b>DATE</b> <i>21 October 2003</i>
---	--	---------------------------------------

**PART II – REPAIR PARTS AND SPECIAL TOOL LISTS AND SUPPLY CATALOGS/SUPPLY MANUALS**

<b>PUBLICATION NUMBER</b> TM 10-1670-296-23&P	<b>DATE</b> 30 October 2002	<b>TITLE</b> Unit Manual for Ancillary Equipment for Low Velocity Air Drop Systems
--	--------------------------------	---

PAGE NO.	COLM NO.	LINE NO.	NATIONAL STOCK NUMBER	REFERENCE NO.	FIGURE NO.	ITEM NO.	TOTAL NO. OF MAJOR ITEMS SUPPORTED	RECOMMENDED ACTION
0066 00-1					4			<i>Callout 16 in figure 4 is pointed to a <u>D-Ring</u>. In the Repair Parts List key for figure 4, item 16 is called a <u>Snap Hook</u>. Please correct one or the other.</i>

**PART III – REMARKS** (Any general remarks or recommendations, or suggestions for improvement of publications and blank forms. Additional blank sheets may be used if more space is needed.)

--	--	--

TYPED NAME, GRADE OR TITLE	TELEPHONE EXCHANGE/AUTOVON, PLUS EXTENSION	SIGNATURE
----------------------------	--	-----------

<b>RECOMMENDED CHANGES TO PUBLICATIONS AND BLANK FORMS</b>						Use Part II (reverse) for Repair Parts and Special Tool Lists (RPSTL) and Supply Catalogs/Supply Manuals (SC/SM).	DATE
For use of this form, see AR 25-30; the proponent agency is ODISC4.							
<b>TO:</b> (Forward to proponent of publication or form) (Include ZIP Code) COMMANDER U.S. ARMY TANK-AUTOMOTIVE AND ARMAMENT COMMAND ATTN:AMSTA-LC-CECT 15 KANSAS STREET NATICK, MA 01760-5052						<b>FROM:</b> (Activity and location) (Include ZIP Code)	
<b>PART I – ALL PUBLICATIONS (EXCEPT RPSTL AND SC/SM) AND BLANK FORMS</b>							
PUBLICATION/FORM NUMBER TM 10-1670-279-23&P				DATE 30 AUGUST 1989		TITLE UNIT AND INTERMEDIATE DIRECT SUPPORT (DS) MAINTENANCE MANUAL (INCLUDING REPAIR PARTS AND SPECIAL TOOLS LIST) FOR PARACHUTE, CARGO TYPE: 22-FOOT DIAMETER, CARGO EXTRACTION PARACHUTE	
ITEM NO.	PAGE NO.	PARA- GRAPH	LINE NO. *	FIGURE NO.	TABLE NO.	RECOMMENDED CHANGES AND REASON <i>(Provide exact wording of recommended changes, if possible).</i>	
<i>*Reference to line numbers within the paragraph or subparagraph.</i>							
TYPED NAME, GRADE OR TITLE				TELEPHONE EXCHANGE/AUTOVON, PLUS EXTENSION		SIGNATURE	

<b>TO:</b> <i>(Forward direct to addressee listed in publication)</i> COMMANDER U.S. ARMY TANK-AUTOMOTIVE AND ARMAMENT COMMAND ATTN:AMSTA-LC-CECT 15 KANSAS STREET NATICK, MA 01760-5052	<b>FROM:</b> <i>(Activity and location) (Include ZIP Code)</i>	<b>DATE</b>
---	--	-------------

**PART II – REPAIR PARTS AND SPECIAL TOOL LISTS AND SUPPLY CATALOGS/SUPPLY MANUALS**

PUBLICATION NUMBER TM 10-1670-279-23&P	DATE 30 AUGUST 1989	TITLE UNIT AND INTERMEDIATE DIRECT SUPPORT (DS) MAINTENANCE MANUAL (INCLUDING REPAIR PARTS AND SPECIAL TOOLS LIST) FOR PARACHUTE, CARGO TYPE: 22-FOOT DIAMETER, CARGO EXTRACTION PARACHUTE
---	------------------------	---

PAGE NO.	COLM NO.	LINE NO.	NATIONAL STOCK NUMBER	REFERENCE NO.	FIGURE NO.	ITEM NO.	TOTAL NO. OF MAJOR ITEMS SUPPORTED	RECOMMENDED ACTION

**PART III – REMARKS** *(Any general remarks or recommendations, or suggestions for improvement of publications and blank forms. Additional blank sheets may be used if more space is needed.)*

--

TYPED NAME, GRADE OR TITLE	TELEPHONE EXCHANGE/AUTOVON, PLUS EXTENSION	SIGNATURE
----------------------------	--	-----------

<b>RECOMMENDED CHANGES TO PUBLICATIONS AND BLANK FORMS</b>  For use of this form, see AR 25-30; the proponent agency is ODISC4.	Use Part II (reverse) for Repair Parts and Special Tool Lists (RPSTL) and Supply Catalogs/Supply Manuals (SC/SM).	DATE
---	---	------

<b>TO:</b> (Forward to proponent of publication or form) (Include ZIP Code) COMMANDER U.S. ARMY TANK-AUTOMOTIVE AND ARMAMENT COMMAND ATTN:AMSTA-LC-CECT 15 KANSAS STREET NATICK, MA 01760-5052	<b>FROM:</b> (Activity and location) (Include ZIP Code)
---	---

**PART I – ALL PUBLICATIONS (EXCEPT RPSTL AND SC/SM) AND BLANK FORMS**

PUBLICATION/FORM NUMBER TM 10-1670-279-23&P	DATE 30 AUGUST 1989	TITLE UNIT AND INTERMEDIATE DIRECT SUPPORT (DS) MAINTENANCE MANUAL (INCLUDING REPAIR PARTS AND SPECIAL TOOLS LIST) FOR PARACHUTE, CARGO TYPE: 22-FOOT DIAMETER, CARGO EXTRACTION PARACHUTE
--	------------------------	---

ITEM NO.	PAGE NO.	PARA-GRAPH	LINE NO. *	FIGURE NO.	TABLE NO.	RECOMMENDED CHANGES AND REASON <i>(Provide exact wording of recommended changes, if possible).</i>

*\*Reference to line numbers within the paragraph or subparagraph.*

TYPED NAME, GRADE OR TITLE	TELEPHONE EXCHANGE/AUTOVON, PLUS EXTENSION	SIGNATURE
----------------------------	--	-----------

<b>TO:</b> <i>(Forward direct to addressee listed in publication)</i> COMMANDER U.S. ARMY TANK-AUTOMOTIVE AND ARMAMENT COMMAND ATTN:AMSTA-LC-CECT 15 KANSAS STREET NATICK, MA 01760-5052	<b>FROM:</b> <i>(Activity and location) (Include ZIP Code)</i>	<b>DATE</b>
---	--	-------------

**PART II – REPAIR PARTS AND SPECIAL TOOL LISTS AND SUPPLY CATALOGS/SUPPLY MANUALS**

PUBLICATION NUMBER TM 10-1670-279-23&P	DATE 30 AUGUST 1989	TITLE UNIT AND INTERMEDIATE DIRECT SUPPORT (DS) MAINTENANCE MANUAL (INCLUDING REPAIR PARTS AND SPECIAL TOOLS LIST) FOR PARACHUTE, CARGO TYPE: 22-FOOT DIAMETER, CARGO EXTRACTION PARACHUTE
---	------------------------	---

PAGE NO.	COLM NO.	LINE NO.	NATIONAL STOCK NUMBER	REFERENCE NO.	FIGURE NO.	ITEM NO.	TOTAL NO. OF MAJOR ITEMS SUPPORTED	RECOMMENDED ACTION

**PART III – REMARKS** *(Any general remarks or recommendations, or suggestions for improvement of publications and blank forms. Additional blank sheets may be used if more space is needed.)*

--

TYPED NAME, GRADE OR TITLE	TELEPHONE EXCHANGE/AUTOVON, PLUS EXTENSION	SIGNATURE
----------------------------	--	-----------

# The Metric System and Equivalents

## Linear Measure

1 centimeter = 10 millimeters = .39 inch  
 1 decimeter = 10 centimeters = 3.94 inches  
 1 meter = 10 decimeters = 39.37 inches  
 1 dekameter = 10 meters = 32.8 feet  
 1 hectometer = 10 dekameters = 328.08 feet  
 1 kilometer = 10 hectometers = 3,280.8 feet

## Weights

1 centigram = 10 milligrams = .15 grain  
 1 decigram = 10 centigrams = 1.54 grains  
 1 gram = 10 decigrams = .035 ounce  
 1 dekagram = 10 grams = .35 ounce  
 1 hectogram = 10 dekagrams = 3.52 ounces  
 1 kilogram = 10 hectograms = 2.2 pounds  
 1 quintal = 100 kilograms = 220.46 pounds  
 1 metric ton = 10 quintals = 1.1 short tons

## Liquid Measure

1 centiliter = 10 milliliters = .34 fl. ounce  
 1 deciliter = 10 centiliters = 3.38 fl. ounces  
 1 liter = 10 deciliters = 33.81 fl. ounces  
 1 dekaliter = 10 liters = 2.64 gallons  
 1 hectoliter = 10 dekaliters = 26.42 gallons  
 1 kiloliter = 10 hectoliters = 264.18 gallons

## Square Measure

1 sq. centimeter = 100 sq. millimeters = .155 sq. inch  
 1 sq. decimeter = 100 sq. centimeters = 15.5 sq. inches  
 1 sq. meter (centare) = 100 sq. decimeters = 10.76 sq. feet  
 1 sq. dekameter (are) = 100 sq. meters = 1,076.4 sq. feet  
 1 sq. hectometer (hectare) = 100 sq. dekameters = 2.47 acres  
 1 sq. kilometer = 100 sq. hectometers = .386 sq. mile

## Cubic Measure

1 cu. centimeter = 1000 cu. millimeters = .06 cu. inch  
 1 cu. decimeter = 1000 cu. centimeters = 61.02 cu. inches  
 1 cu. meter = 1000 cu. decimeters = 35.31 feet

## Approximate Conversion Factors

<i>To change</i>	<i>To</i>	<i>Multiply by</i>	<i>To change</i>	<i>To</i>	<i>Multiply by</i>
inches	centimeters	2.540	ounce-inches	newton-meters	.007062
feet	meters	.305	centimeters	inches	.394
yards	meters	.914	meters	feet	3.280
miles	kilometers	1.609	meters	yards	1.094
square inches	square centimeters	6.451	kilometers	miles	.621
square feet	square meters	.093	square centimeters	square inches	.155
square yards	square meters	.836	square meters	square feet	10.764
square miles	square kilometers	2.590	square meters	square yards	1.196
acres	square hectometers	.405	square kilometers	square miles	.386
cubic feet	cubic meters	.028	square hectometers	acres	2.471
cubic yards	cubic meters	.765	cubic meters	cubic feet	35.315
fluid ounces	milliliters	29.573	cubic meters	cubic yards	1.308
pints	liters	.473	milliliters	fluid ounces	.034
quarts	liters	.946	liters	pints	2.113
gallons	liters	3.785	liters	quarts	1.057
ounces	grams	28.349	liters	gallons	.264
pounds	kilograms	.454	grams	ounces	.035
short tons	metric tons	.907	kilograms	pounds	2.205
pound-feet	newton-meters	1.356	metric tons	short tons	1.102
pound-inches	newton-meters	.11296			

## Temperature (Exact)

  °F Fahrenheit temperature  $\times \frac{5}{9}$  (after subtracting 32) = Celsius temperature   °C

**PIN: 066622-000**